

# Simulating the Effects of Single-Event and Radiation Phenomena on GaAs MESFET Integrated Circuits

Peter George, Ping K. Ko and Chenming Hu

ERL & EECS, University of California at Berkeley, Berkeley, CA 94720

## Abstract

This paper describes a device model for the simulation of the effects of single-event and radiation phenomena on the operation of GaAs MESFETs. The model can be utilized in a circuit simulator to evaluate integrated circuit designs and aid in the provision of adequate upset margins for various operating environments. Additional sub-circuit construction is unnecessary since the electrical responses to the different phenomena are intrinsic to the device template. Example simulations using SPICE3 are described.

## Introduction

GaAs integrated circuits are finding increasing use in applications which require high performance and resistance to circuit upset due to single-event and radiation phenomena. The environments in which these circuits have to function reliably are characterized by the presence of both transient upset and cumulative degradation mechanisms in the form of cosmic ray particles, trace amounts of terrestrial actinides, ionization due to high-energy photons and damage due to particle fluence. It is therefore important to account for these during the design process to provide adequate margins for reliable operation. A GaAs MESFET device model and companion models for a dielectric capacitor and an implanted resistor, that can be used to evaluate the effects of some of the above phenomena on device and circuit operation using a circuit simulator, are described below.

## Mechanisms and Device Models

Ionizing radiation creates hole-electron pairs everywhere in the MESFET. The carriers that do not immediately recombine are separated by the prevailing electric fields in the device regions and contribute to charge transfer between the different nodes of the device. Transients in the electrical characteristics during the radiation stimulus are termed prompt and those which persist after the stimulus is removed are classified as delayed. The mechanisms provided in the MESFET model in the former category are radiation induced currents through the internal access resistors, prompt leakage in the gate Schottky diodes, prompt substrate leakage current between the drain and source electrodes and a prompt increase in the channel current. The mechanisms in the latter category are delayed substrate leakage, charge collection by

diffusion in the gate Schottky diodes and slow drift of the channel current due to carriers trapped in deep levels. Particle fluence, which creates cumulative lattice damage, causes reductions in channel mobility and effective doping density. These in turn lead to reduced peak device current, threshold voltage shift and transconductance degradation. Single-event phenomena, in which a few high energy particles strike the MESFET, cause upset by charge transfer due to the electron-hole pair tracks that are created in the device. Funneling and source-drain penetration are the two main modes in this category. On-chip semiconductor resistors and film capacitors also exhibit additional shunt conductivity due to both dose-rate ( $\dot{\gamma}$ ) and single-event effects.

The simulation approach adopted here departs from the commonly used sub-circuit method [1], [2]. The device sparse matrix template is computed in terms of an environmental variable called flux which is determined by flux sources. This approach allows the simulation of changes induced in the internal device parameters like threshold voltage, mobility and effective doping and also eliminates the need to maintain different device templates and additional sub-circuit elements to mimic different phenomena.

**Capacitor:** The capacitor circuit element is augmented with a leakage current source to model effects of ionizing radiation. This additional current between the two nodes is expressed as the sum of a prompt component, which is directly proportional to the dose-rate, and a delayed component specified by a convolution integral [3]:

$$I_{sca} = V_c \left[ K_{cp} [\dot{\gamma}(t)]^{b_{cp}} + \sum_{i=1}^2 K_{cdi} \int_0^t [\dot{\gamma}(u)]^{b_{cdi}} e^{-\frac{-(t-u)}{\tau_{cdi}}} du \right] \quad (1)$$

$V_c$  is the voltage across the capacitor,  $K_{cp}$  and  $K_{cdi}$  are conductivity constants,  $b_{cp}$  and  $b_{cdi}$  are the related exponents, and  $\tau_{cdi}$  is the decay time-constant. The electron-hole pair tracks created by high energy particle transits through the capacitor or the resistor are modeled as highly conductive shunt paths.

**Semiconductor Resistor:** The effect of ionizing radiation on resistors, including the internal access resistors of the MESFET, is modeled by an additional current of the form [3]:

## 9.7.1

$$\hat{I}_{sr} = V_r K_r [\dot{\gamma}(t)]^{b_r} \quad (2)$$

where  $V_r$  is the voltage across the resistor,  $K_r$  is the conductivity constant and  $b_r$  is the dose-rate exponent.

**GaAs MESFET:** The MESFET equivalent circuit is shown in Figure (1) with the radiation and particle track dependencies incorporated in it. The internal access resistors  $R_{di}$  and  $R_{si}$  have the same description as the semiconductor resistor in the previous section. The non-linear capacitors associated with the Schottky gate have no built-in radiation/particle track dependencies. These have been attributed to the Schottky diodes shown in the equivalent circuit. The external lead/interconnect resistors  $R_{de}$ ,  $R_{ge}$  and  $R_{se}$  have no radiation/track dependencies. The additional substrate photo-current [4] between the source and drain contacts is modeled to show both prompt and delayed responses to incident radiation. It is given by:

$$\hat{I}_{ssub} = V_{sub} \left[ K_{psub} \dot{\gamma}(t) + \int_0^t K_{dsub} \dot{\gamma}(u) e^{-\frac{(t-u)}{\tau_{sub}}} du \right] \quad (3)$$

Here,  $V_{sub}$  is the voltage across the nodes of the shunt element,  $K_{psub}$  is the prompt conductivity constant,  $K_{dsub}$  is the delayed conductivity constant and  $\tau_{sub}$  is the associated time-constant. The additional current through the gate Schottky diodes is given by [5]:

$$\hat{I}_{sgx} = qA \left[ f_{px} L_{cx} \dot{\gamma}(t) + \frac{f_{dx}}{\sqrt{\pi}} \int_0^t \dot{\gamma}(t-u) \sqrt{D_p} e^{-\frac{u}{\tau_p}} \frac{du}{\sqrt{u}} \right] \quad (4)$$

Here  $x = s$  or  $d$  for the source or drain,  $f_{px}$  and  $f_{dx}$  are prompt and delayed proportionality constants,  $A$  is the area of the diode,  $L_{cx}$  is the collection length,  $D_p$  and  $\tau_p$  are the hole diffusion constant and recombination lifetime respectively. The prompt increase in channel current due to ionizing radiation is modeled by augmenting the maximum channel current, which is a device model parameter, as a function of the dose rate:

$$\Delta \hat{I}_{cho} = K_{cho} [\dot{\gamma}(t)]^{b_i} \quad (5)$$

Long term negative drain current transients [6] are modeled by re-expressing the threshold voltage of the device as a function of trapped charge in the device. Total dose effects are principally represented by a reduction in mobility and effective doping density [7]:

$$\mu_{eff} = \frac{\mu_0}{1 + K_\mu \gamma} \quad (6)$$

$$N_{eff} = N_d \left[ 1 - K_N \gamma \right] \quad (7)$$

where  $K_\mu$ ,  $K_N$  are constants and  $\gamma$  is the cumulative dose.

The former reduces the linear region conductance and increases the saturation voltage whereas the latter decreases the magnitude of the threshold voltage, maximum channel current and the saturation transconductance. There are two major types of single event upset (SEU) mechanisms that have been identified in GaAs MESFET structures. One is due to the funneling phenomenon [8] similar to that in silicon p-n junctions and the other is due to parasitic bipolar transistor action [9] in the device region below the channel-substrate interface. These particle strikes are modeled by a combination of charge transfers between pairs of internal nodes. Strikes which occur in the gate-drain and gate-source spacings, are modeled as strikes on the internal access resistors. Edge-rate ( $\dot{\gamma}$ ) effects [10] are represented implicitly by the specification of the flux source waveform.

### Implementation and Simulations

The device models have been tested in SPICE3 [11] and example simulations are presented in Figures (2) to (7). The convolution integrals are computed using an adaptive quadrature integration routine. Radiation and particle stimuli are specified in the same manner as electrical sources. Arbitrary track current waveforms can be defined for particle strike simulations through the flux source specification. Figure (2) depicts negative transients of various magnitudes and the long term recovery response of MESFET drain current in response to various x-ray doses. Figure (3) illustrates the edge-rate effect caused by a high rate of change of radiation-induced current through series bus inductance. Figure (4) illustrates a state error due to a particle transit in a clocked inverter. The particle track bridges the gate-drain area of the pull-down device discharging the storage capacitor. Figure (5) shows the schematic and cell waveforms for a simple static RAM cell. A particle strike bridging the drain-source diffusions of A3 and a gate-drain strike on MESFET A4 change the state of the cell. Figures (6) and (7) illustrate the resistor and capacitor models for particle strike and radiation phenomena.

### Summary

A GaAs MESFET device model and companion capacitor and resistor models, suitable for the simulation of the effects of radiation and SEU phenomena on GaAs integrated circuits, were described. Simulation examples of the features of the models using SPICE3 were presented.

### Acknowledgement

This research was supported by the Joint Services Electronics Program under contract # F49620-84-C-0057.

### References

- [1] J. K. Notthoff, R. Zuleeg and G. L. Troeger, *IEEE Trans. Nucl. Sci.*, **NS-30**, 4173 (1983).
- [2] A. T. Brown, L. W. Massengill, S. E. Diehl and J. R. Hauser, *IEEE Trans. Nucl. Sci.*, **NS-33**, 1519 (1986).

[3] G. C. Messenger and M. S. Ash, *The Effects of Radiation on Electronic Systems*, Van Nostrand Reinhold, New York (1986).

[4] R. Zuleeg, J. K. Notthoff and G. L. Troeger, *IEEE Trans. Nucl. Sci.*, **NS-30**, 4151 (1983).

[5] J. L. Wirth and S. C. Rogers, *IEEE Trans. Nucl. Sci.*, **NS-11**, 24 (1964).

[6] M. Simons, E. E. King, W. T. Anderson and H. M. Day, *J. appl. Phys.*, **52**, 6630 (1981).

[7] J. L. McNichols and W. S. Ginell, *IEEE Trans. Nucl. Sci.*, **NS-17**, 52 (1970).

[8] C. Hu, *IEEE Electron Dev. Lett.*, **EDL-3**, 31 (1982).

[9] Y. Umemoto, N. Matsunaga and K. Mitsusada, *Proc. 1988 IEEE IRPS Symp.*, 102 (1988).

[10] W. G. Bartholet, G. W. Stubbs and J. D. Ness, *IEEE Trans. Nucl. Sci.*, **NS-34**, 1438 (1987).

[11] T. Quarles, A. R. Newton, D. O. Pederson and A. Sangiovanni-Vincentelli, *SPICE 3B1 User's Guide*, University of California, Berkeley (1987)

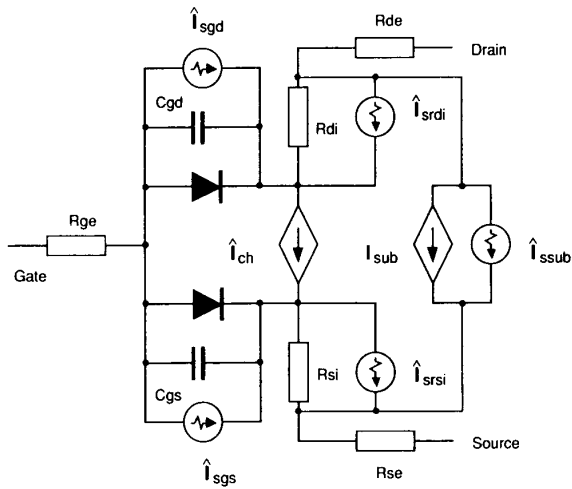

**Figure 1:** Integrated MESFET equivalent circuit incorporating SEU and radiation stimulus dependencies. Additional sub-circuitry is unnecessary.

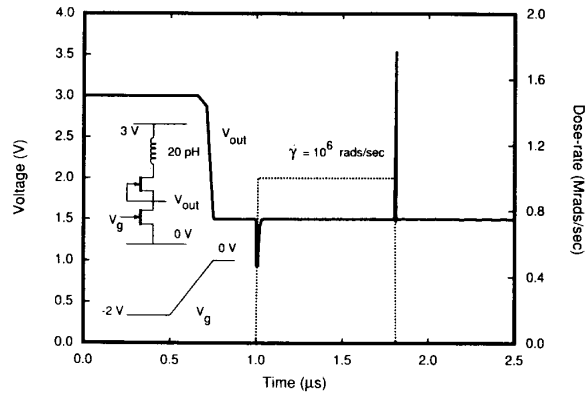

**Figure 3:** Output spikes (edge-rate effect) due to power bus inductance. The output does not change during the stimulus since the incremental conductances are proportional to original sizings.

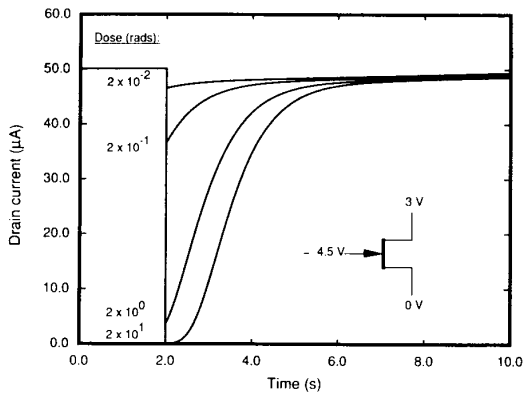

**Figure 2:** MESFET slow drift response for various doses at  $t = 2$  secs. The magnitude of the negative transient saturates at high doses.

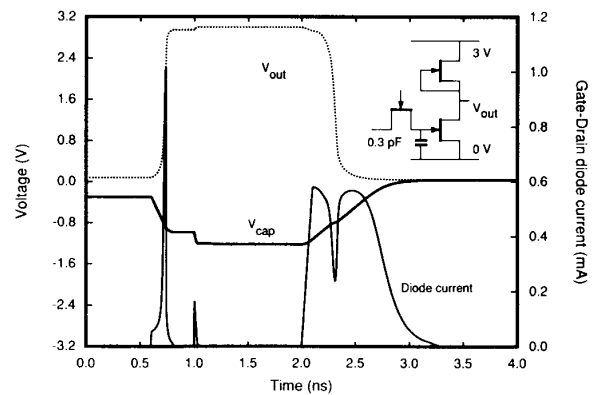

**Figure 4:** Logic upset in a dynamic inverter when a particle strike bridges the internal gate-drain region of the pull-down device.

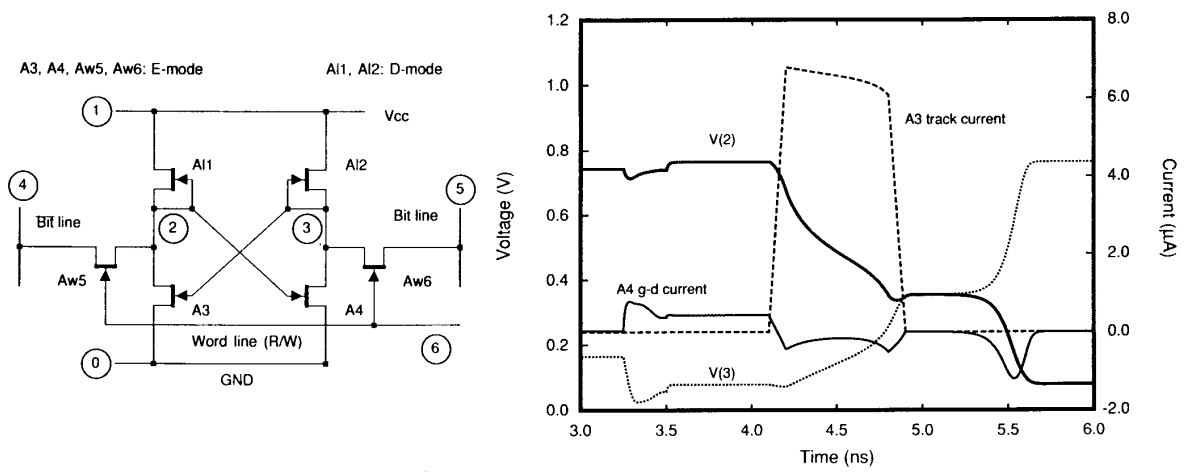

**Figure 5:** GaAs SRAM cell schematic and node voltage waveforms. The cell changes state due to a particle strike on MESFET A3 with source-drain penetration followed by another gate-drain strike on A4.

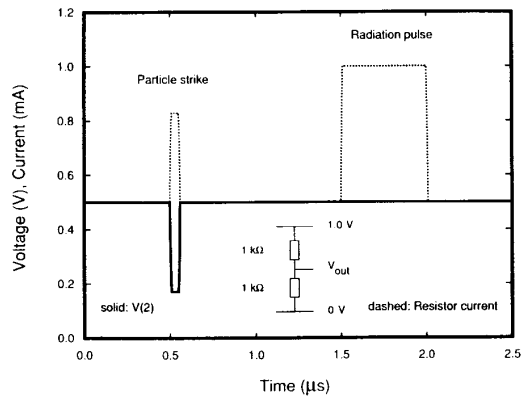

**Figure 6:** A resistive voltage divider subjected to a particle strike on the bottom resistor and a subsequent radiation pulse. The particle track current lowers the output voltage whereas the pulse does not.

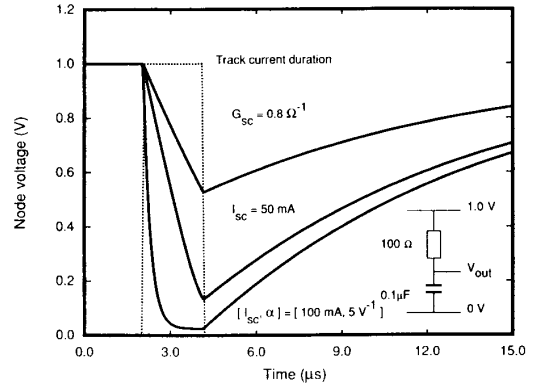

**Figure 7:** Illustration of constant conductance (top), constant current (middle) and velocity saturation models for particle track current in the capacitor model applied to a simple RC circuit.