

Is Witsenhausen's counterexample a relevant toy?

Pulkit Grover
UC Berkeley

with Anant Sahai

Acknowledgments: NSF grant CNS - 0932410 "Cyber-physical systems"

Witsenhausen's counterexample: a brief history

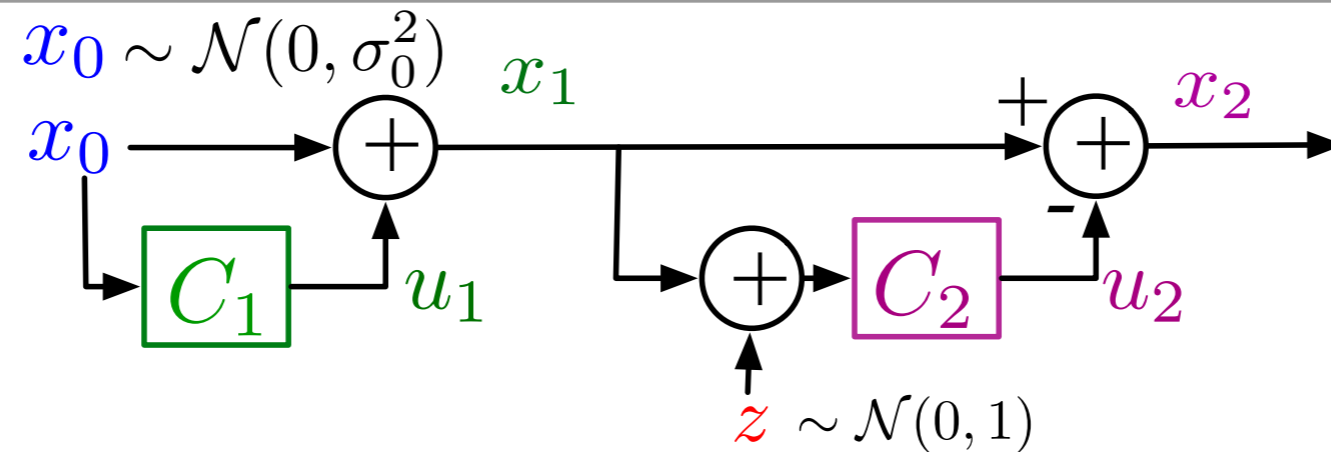

$$\min \{ k^2 \mathbb{E} [u_1^2] + \mathbb{E} [x_2^2] \}$$

Linear, Quadratic, Gaussian

Witsenhausen's counterexample: a brief history

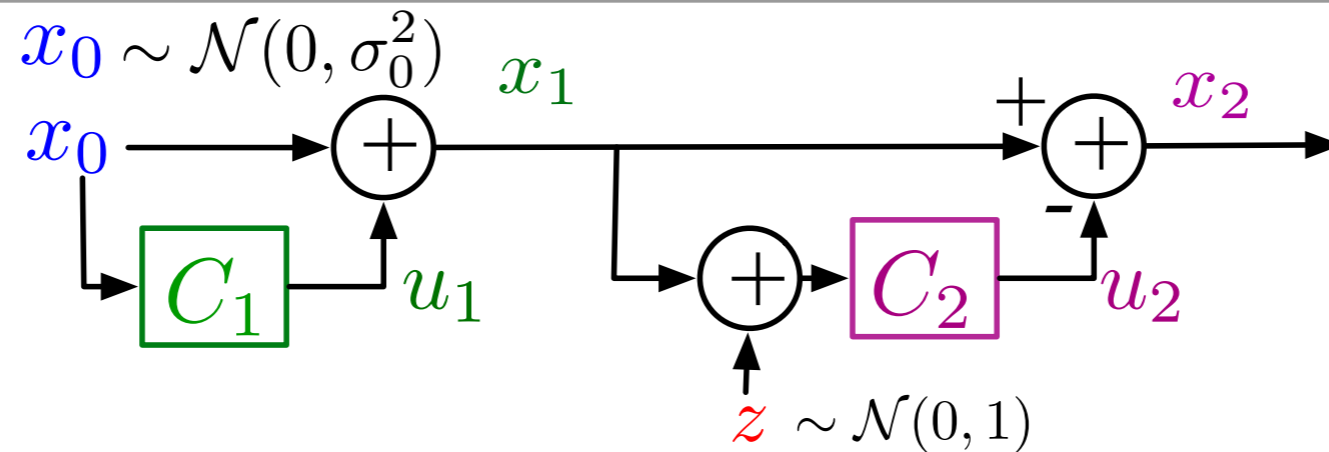

$$\min \{ k^2 \mathbb{E} [u_1^2] + \mathbb{E} [x_2^2] \}$$

Linear, Quadratic, Gaussian

Nonlinear strategies can outperform linear [Witsenhausen '68]

Witsenhausen's counterexample: a brief history

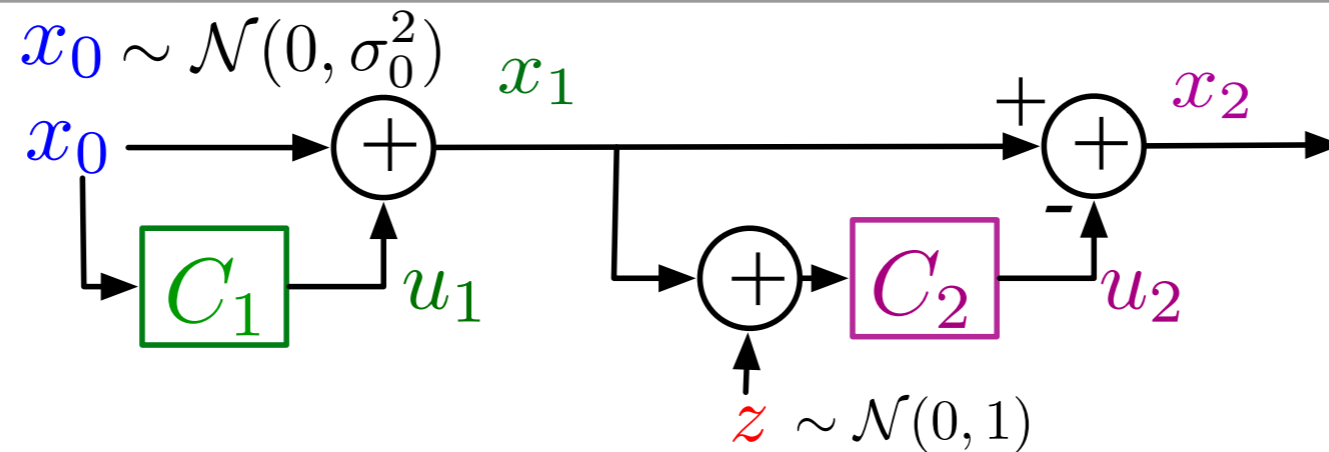

$$\min \{ k^2 \mathbb{E} [u_1^2] + \mathbb{E} [x_2^2] \}$$

Linear, Quadratic, Gaussian

Nonlinear strategies can outperform linear [Witsenhausen '68]

... by an unbounded factor [Mitter, Sahai '99]

Witsenhausen's counterexample: a brief history

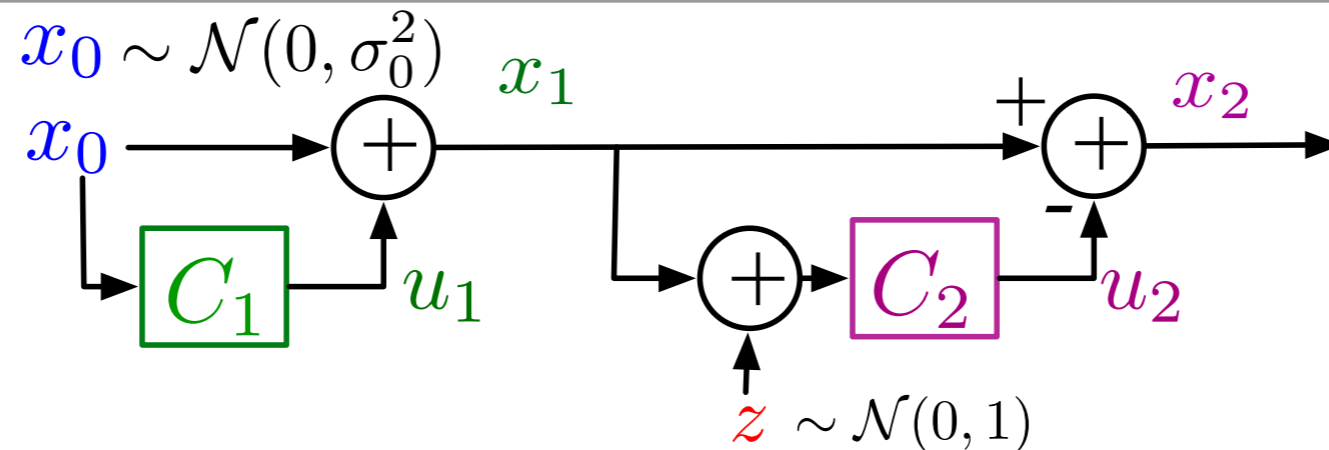

$$\min \{ k^2 \mathbb{E} [u_1^2] + \mathbb{E} [x_2^2] \}$$

Linear, Quadratic, Gaussian

Nonlinear strategies can outperform **linear** [Witsenhausen '68]

... by an **unbounded** factor [Mitter, Sahai '99]

Finding optimal strategy is **nonconvex** [Witsenhausen '68]

NP-hard [Papadimitriou, Tsitsiklis '84]

Witsenhausen's counterexample: a brief history

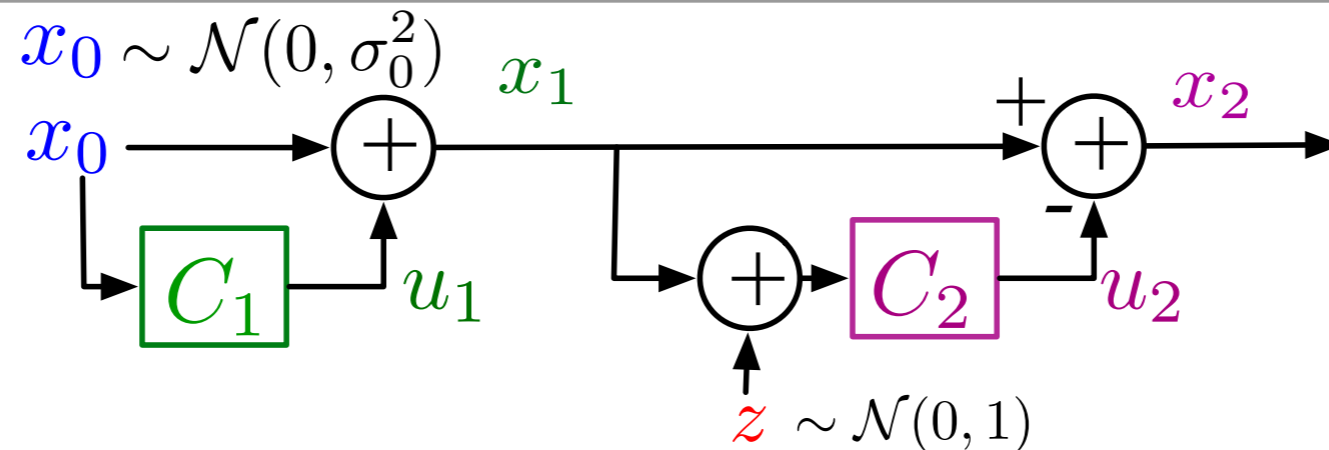

$$\min \{ k^2 \mathbb{E} [u_1^2] + \mathbb{E} [x_2^2] \}$$

Linear, Quadratic, Gaussian

Nonlinear strategies can outperform **linear** [Witsenhausen '68]

... by an **unbounded** factor [Mitter, Sahai '99]

Finding optimal strategy is **nonconvex** [Witsenhausen '68]

NP-hard [Papadimitriou, Tsitsiklis '84]

Semi-exhaustive search techniques [Deng, Ho '99]

[Baglietto, Parisini, Zoppoli '01]

[Lee, Lau, Ho '01]

[Lee, Marden, Shamma '09]

[Karlsson, Gattami, Oechtering, Skoglund '10]

Witsenhausen's counterexample: a signaling perspective

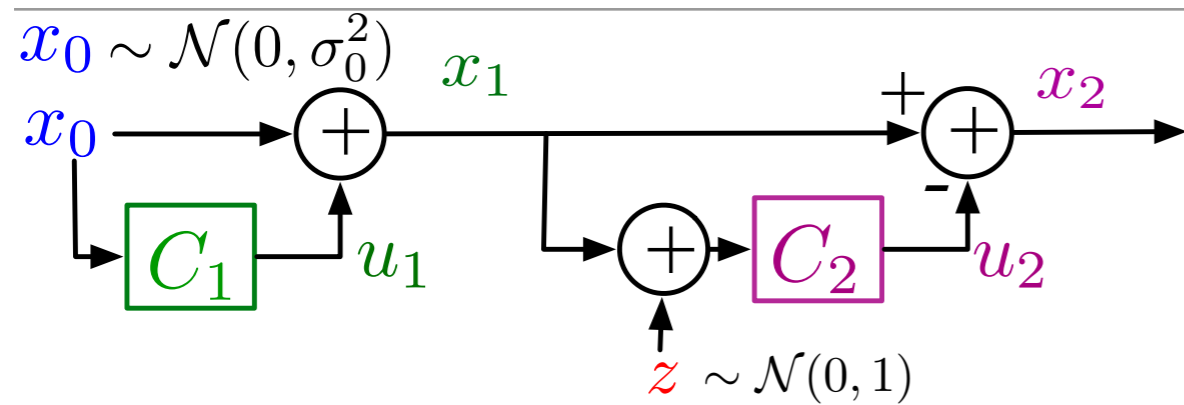

$$\min \{ k^2 \mathbb{E} [u_1^2] + \mathbb{E} [x_2^2] \}$$

The counterexample

Witsenhausen's counterexample: a signaling perspective

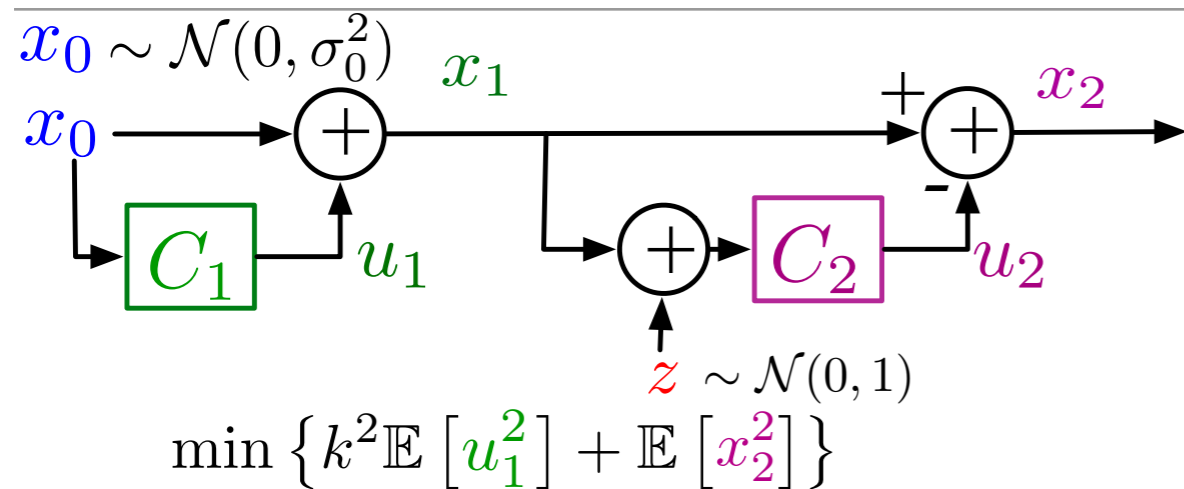

The counterexample

possibility of using **actions** to “signal”

[Ho, Kastner, Wong '78]

[Bansal, Başar '87]

Witsenhausen's counterexample: a signaling perspective

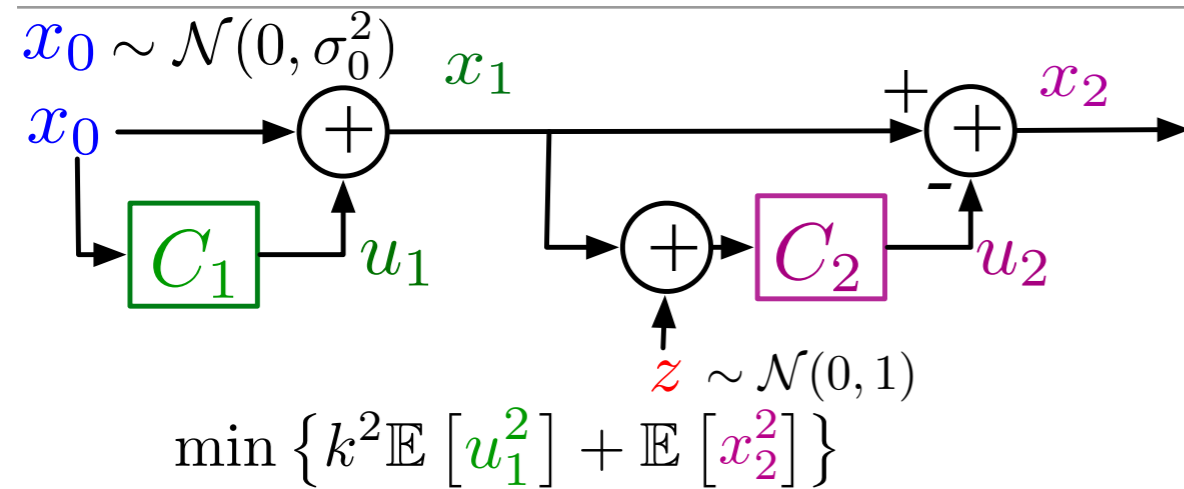

The counterexample

possibility of using **actions** to “signal”

[Ho, Kastner, Wong '78]

[Bansal, Başar '87]

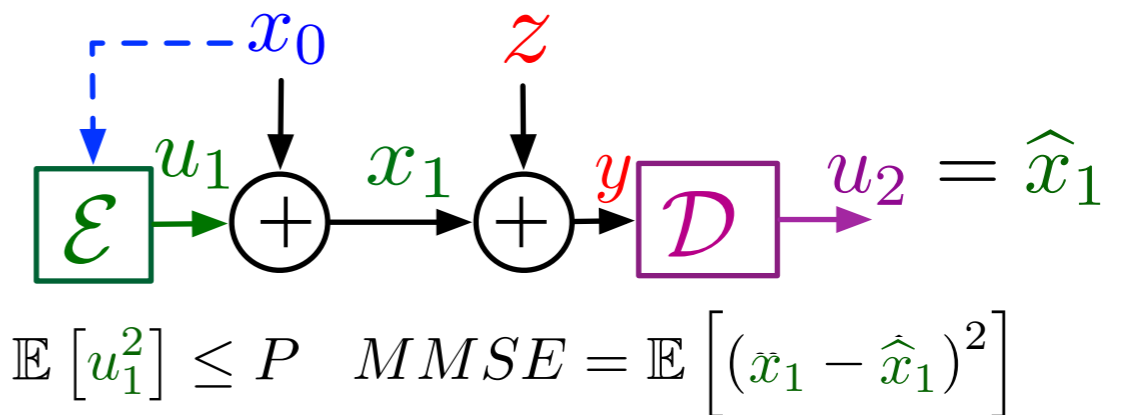

An information-theoretic interpretation

Witsenhausen's counterexample: a signaling perspective

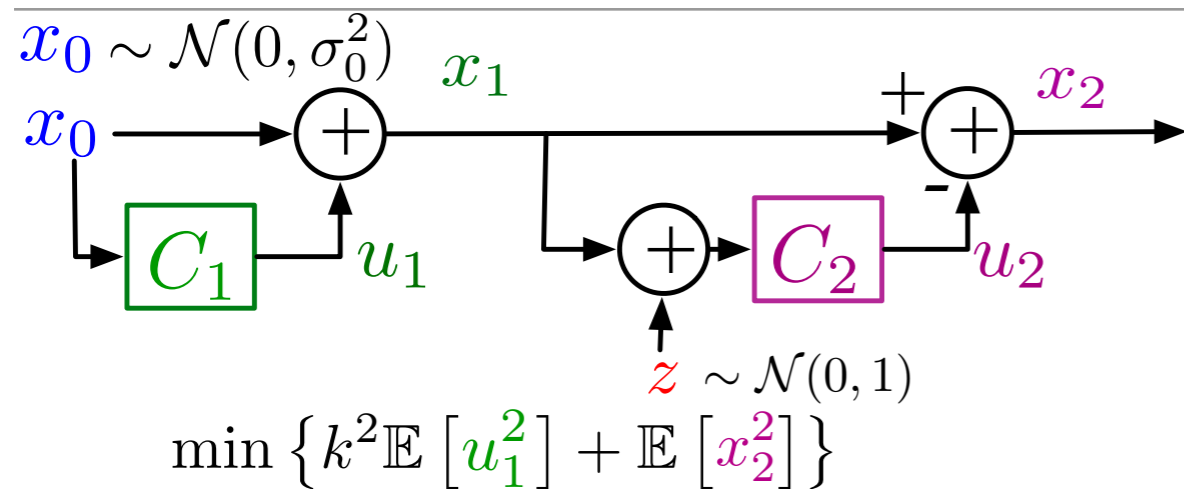

The counterexample

possibility of using **actions** to “signal”

[Ho, Kastner, Wong '78]

[Bansal, Başar '87]

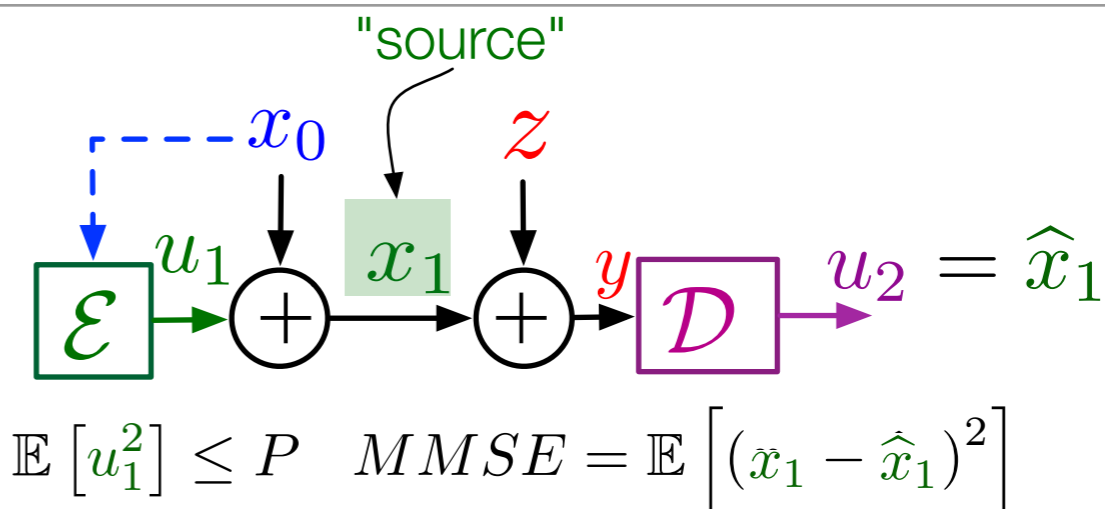

An information-theoretic interpretation

Witsenhausen's counterexample: a signaling perspective

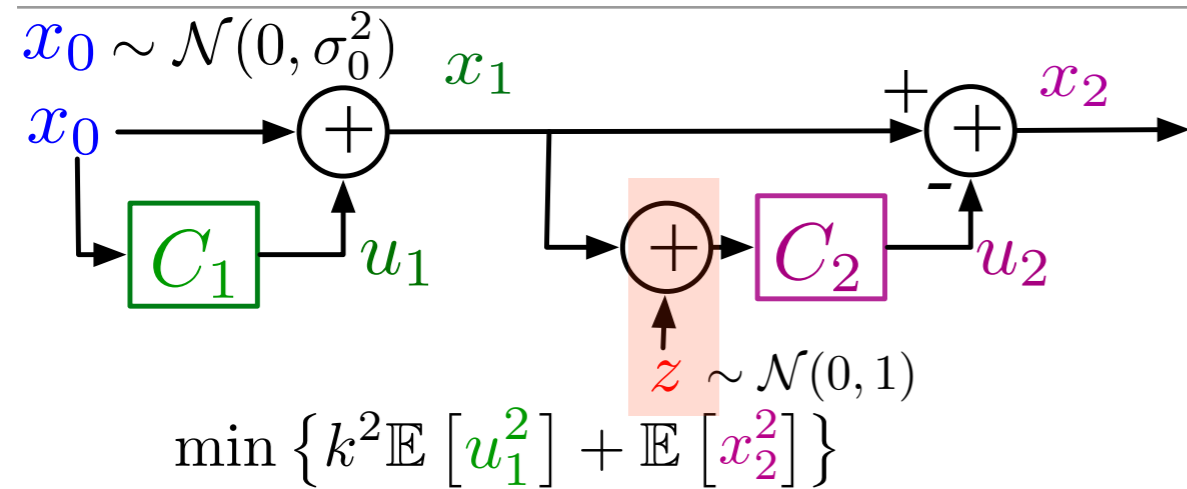

The counterexample

possibility of using **actions** to “signal”

[Ho, Kastner, Wong '78]

[Bansal, Başar '87]

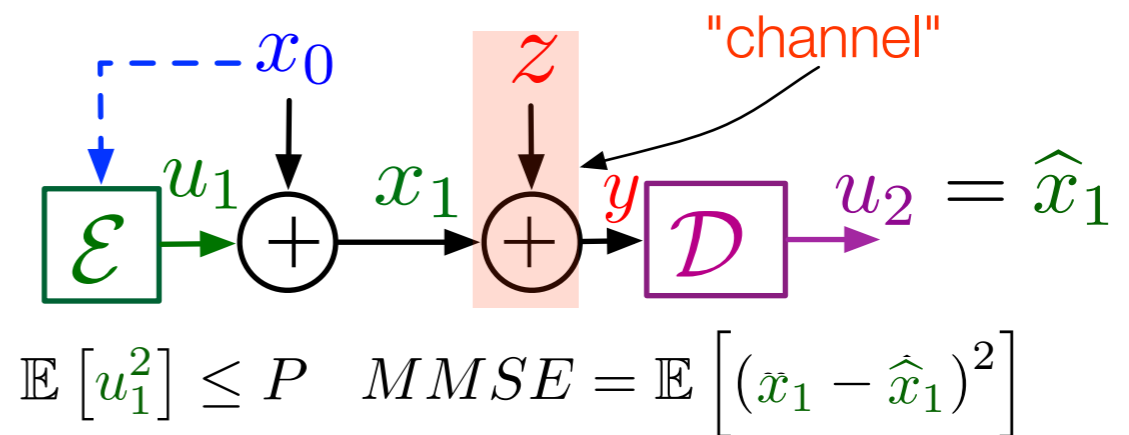

An information-theoretic interpretation

Witsenhausen's counterexample: a signaling perspective

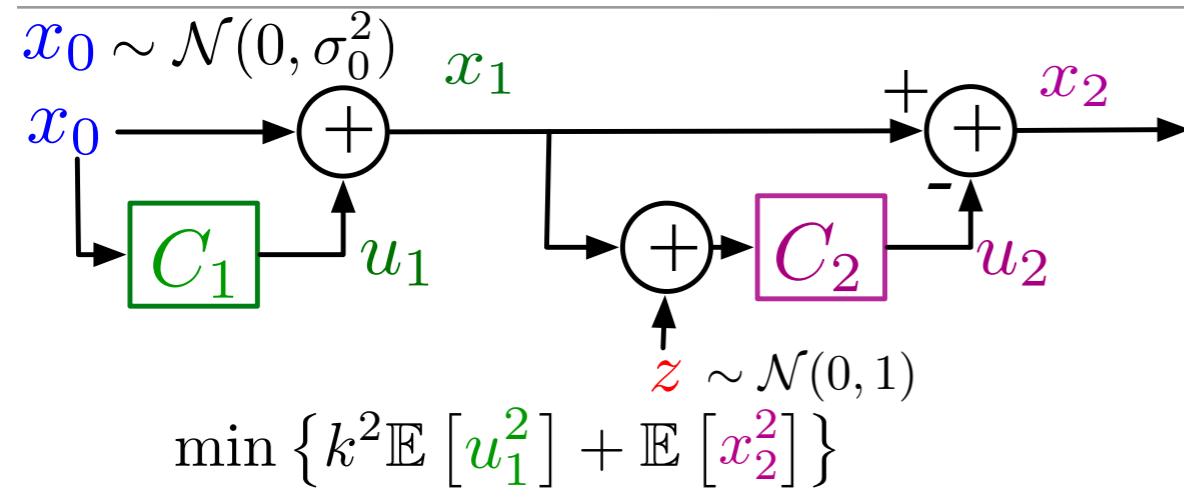

The counterexample

possibility of using **actions** to “signal”

[Ho, Kastner, Wong '78]

[Bansal, Başar '87]

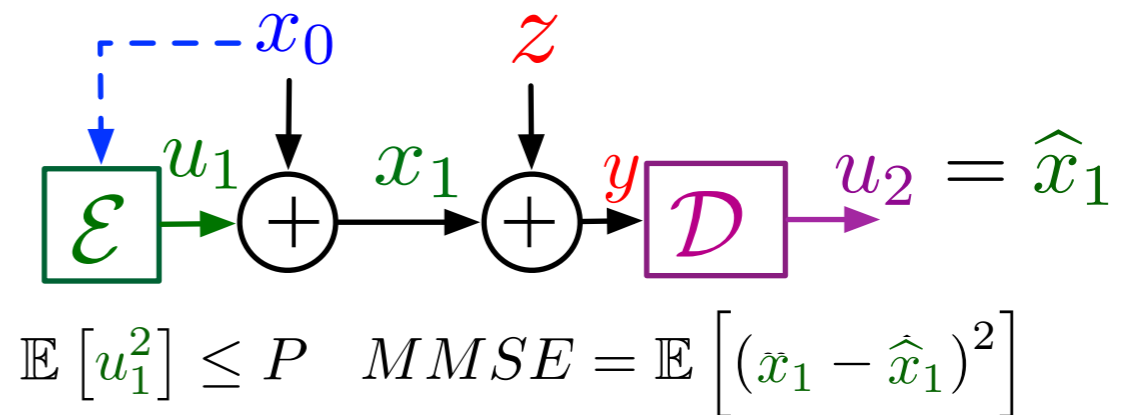

An information-theoretic interpretation

Witsenhausen's counterexample: a signaling perspective

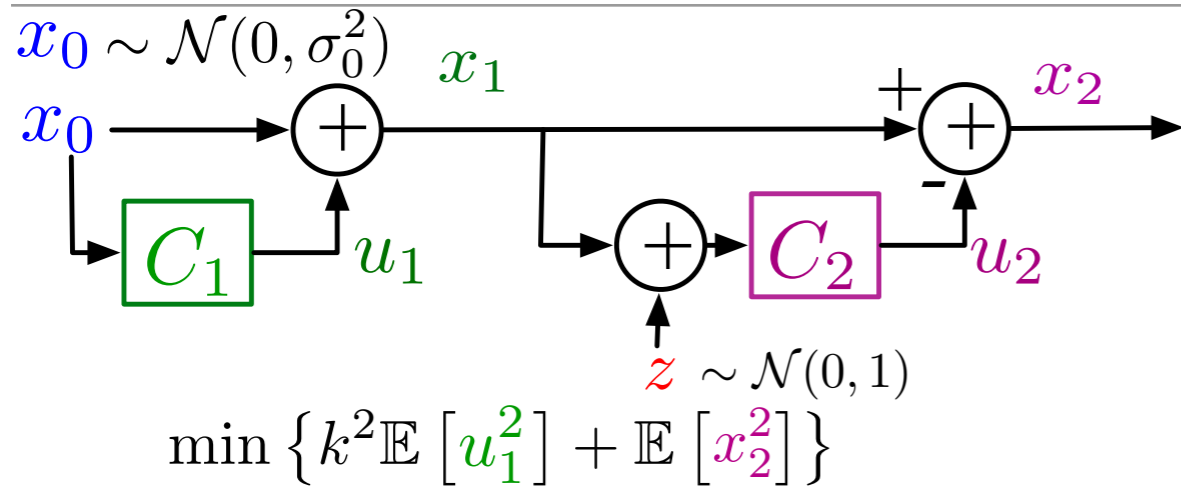

The counterexample

possibility of using **actions** to “signal”

[Ho, Kastner, Wong '78]

[Bansal, Başar '87]

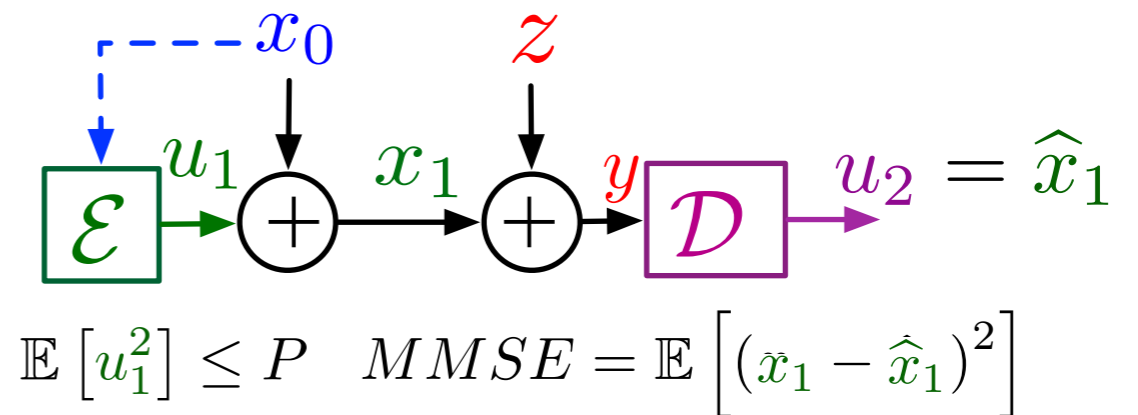

An information-theoretic interpretation

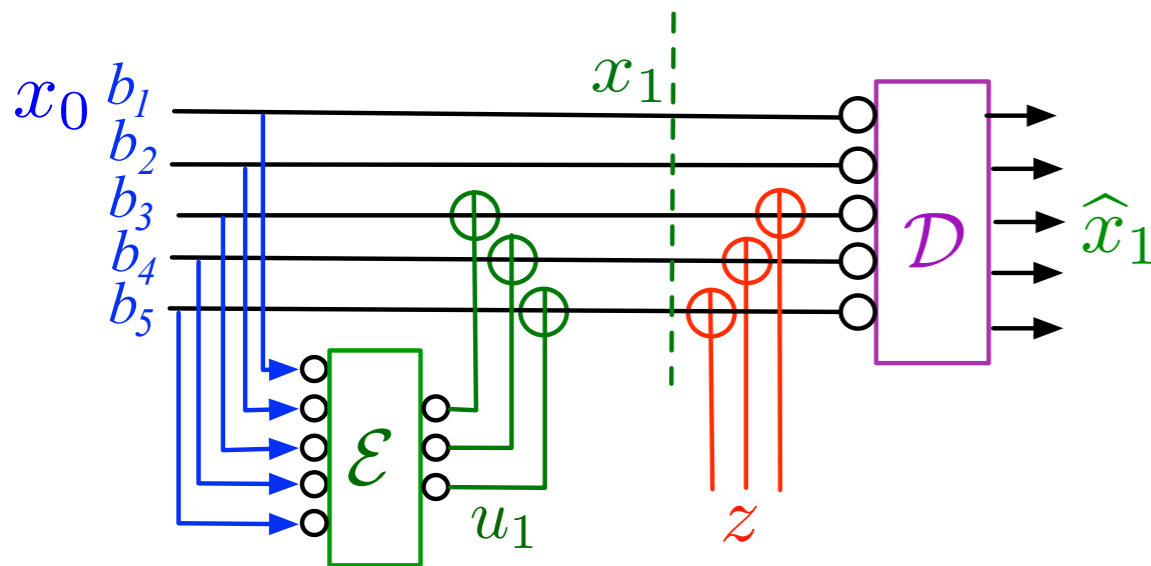

A semi-deterministic model

Witsenhausen's counterexample: a signaling perspective

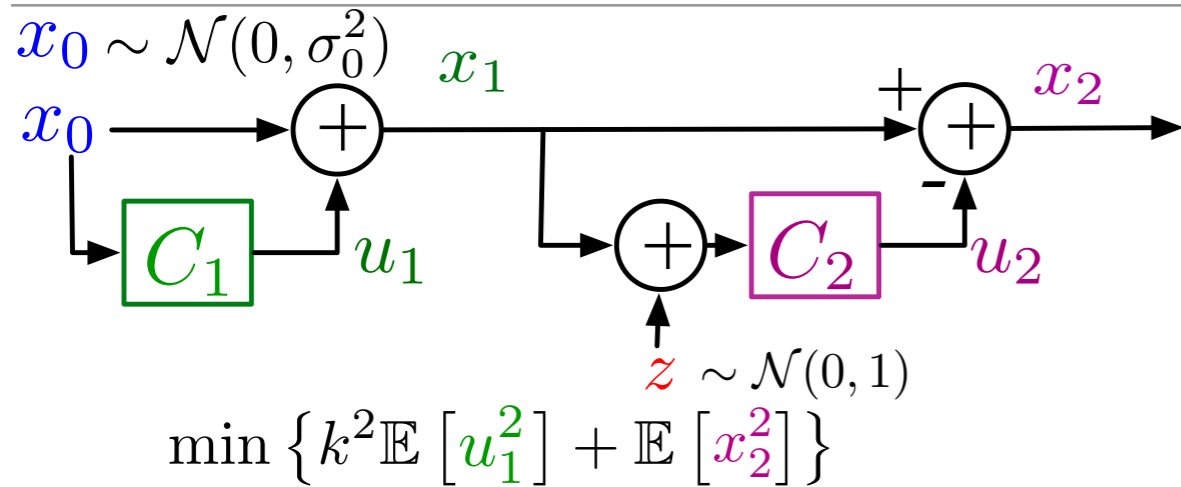

The counterexample

possibility of using **actions** to “signal”

[Ho, Kastner, Wong '78]

[Bansal, Başar '87]

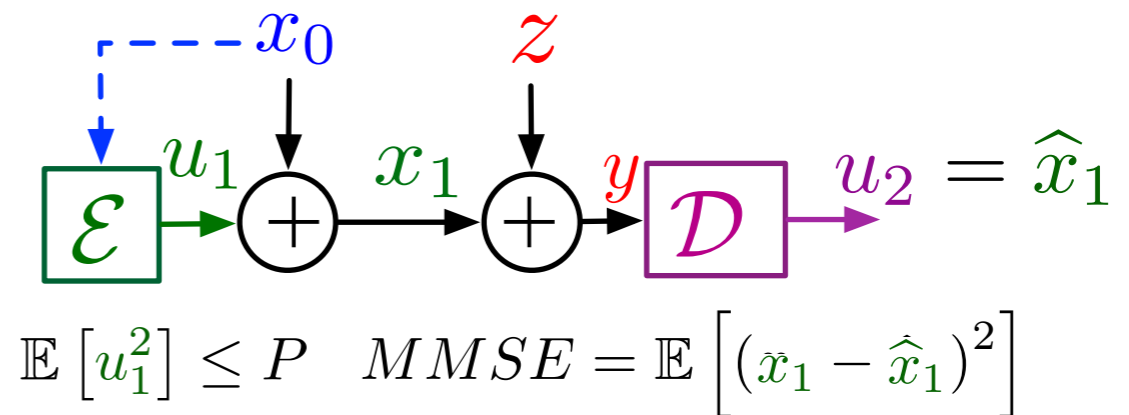

An information-theoretic interpretation

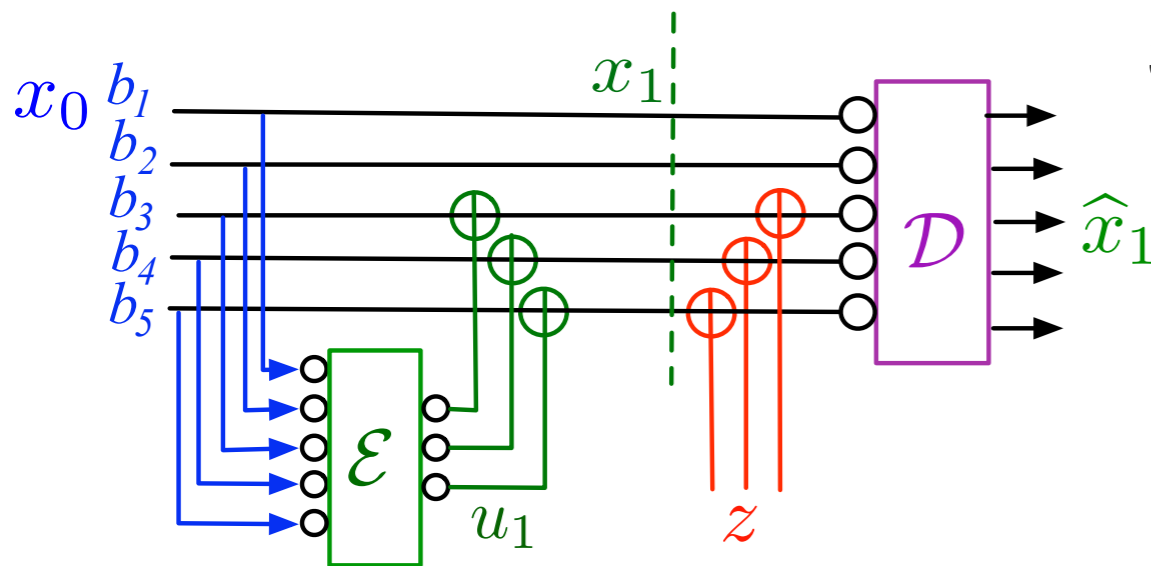

A semi-deterministic model

Strategies for “**signaling**”: quantization

Witsenhausen's counterexample: a signaling perspective

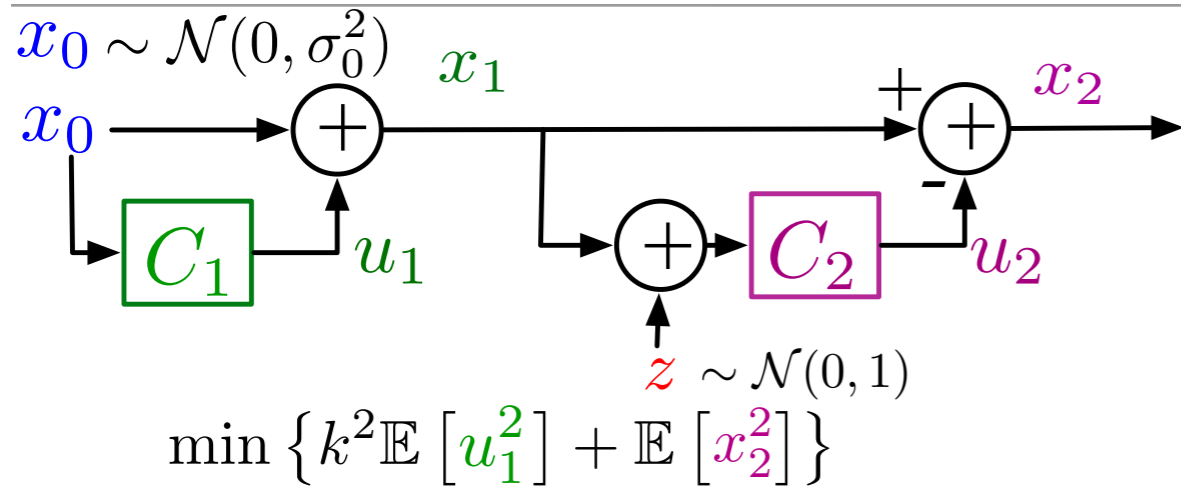

The counterexample

possibility of using **actions** to “signal”

[Ho, Kastner, Wong '78]

[Bansal, Başar '87]

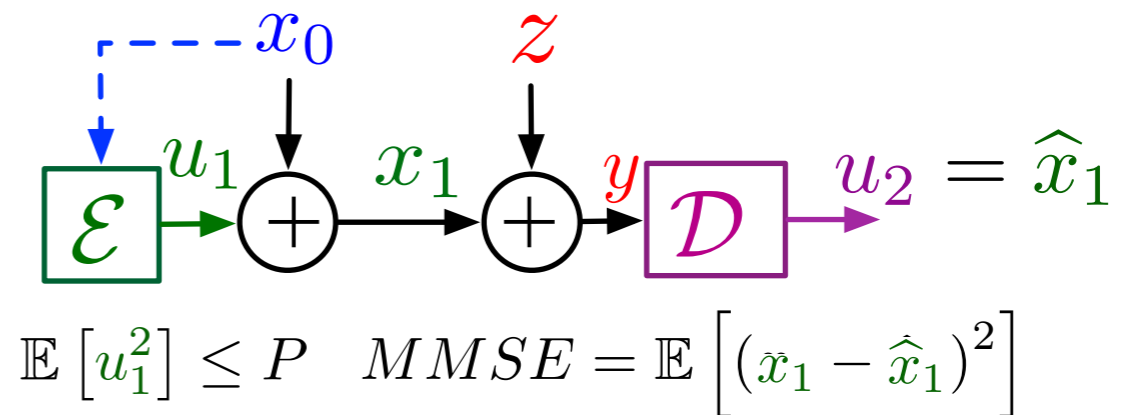

An information-theoretic interpretation

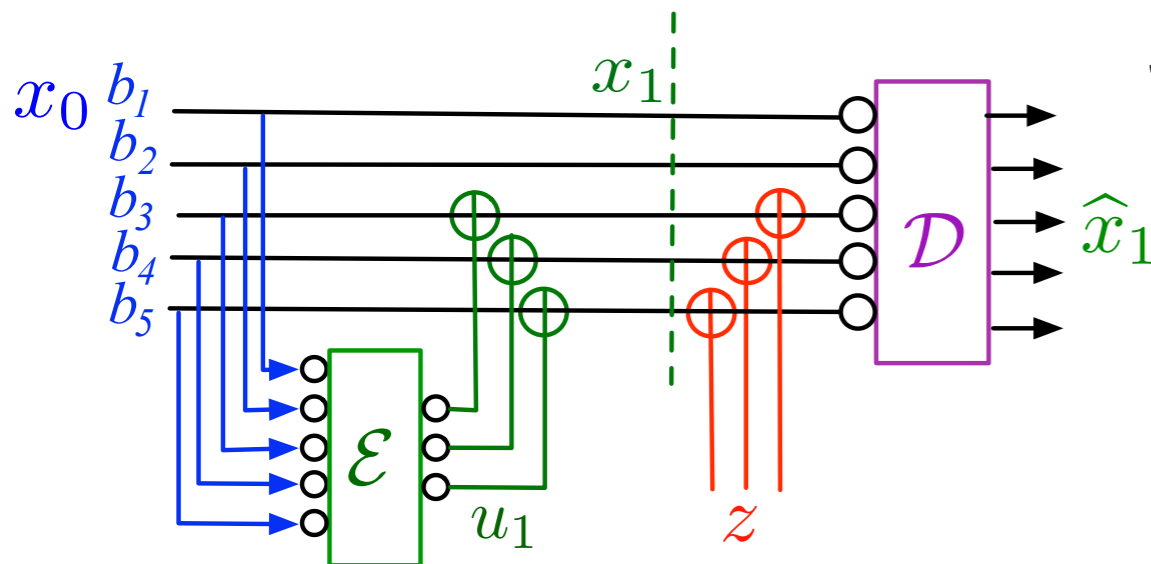

A semi-deterministic model

Strategies for “**signaling**”: quantization

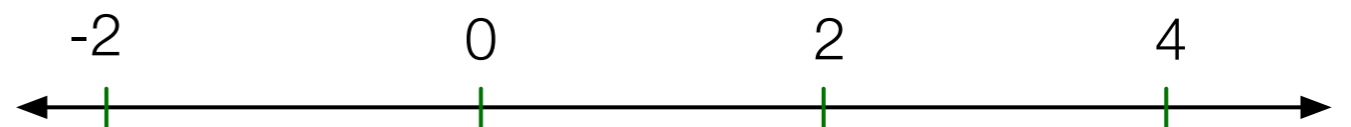

[Witsenhausen '68]

[Mitter, Sahai '99]

Witsenhausen's counterexample: a signaling perspective

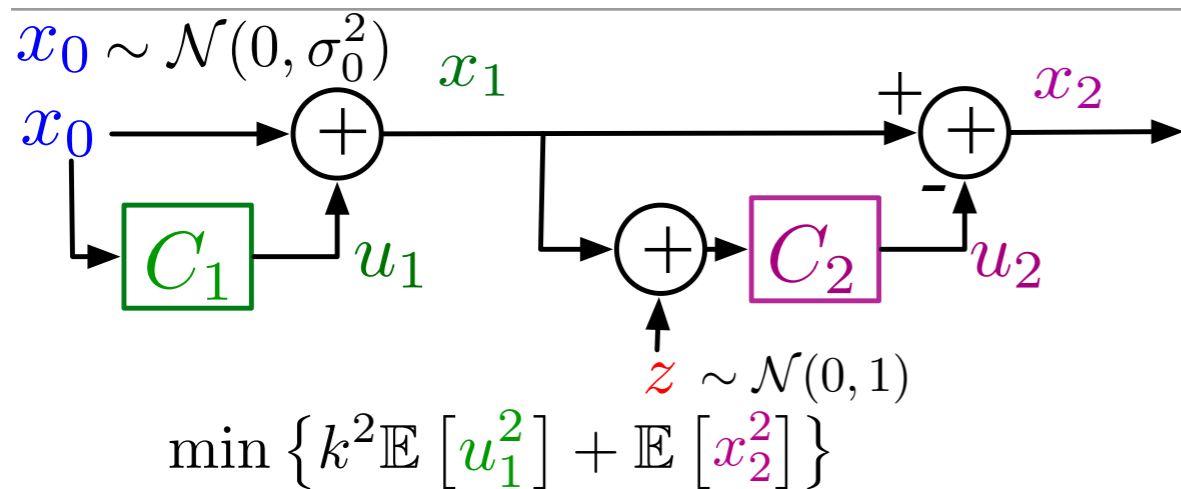

The counterexample

possibility of using **actions** to “signal”

[Ho, Kastner, Wong '78]

[Bansal, Başar '87]

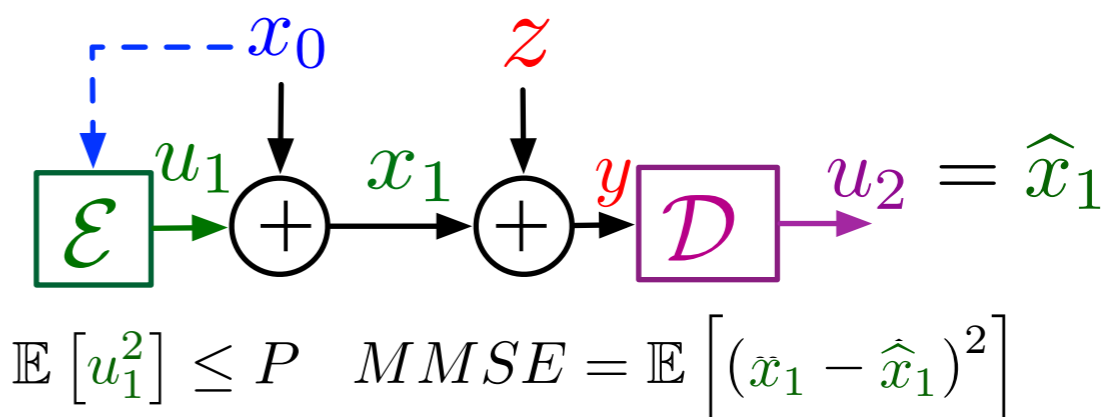

An information-theoretic interpretation

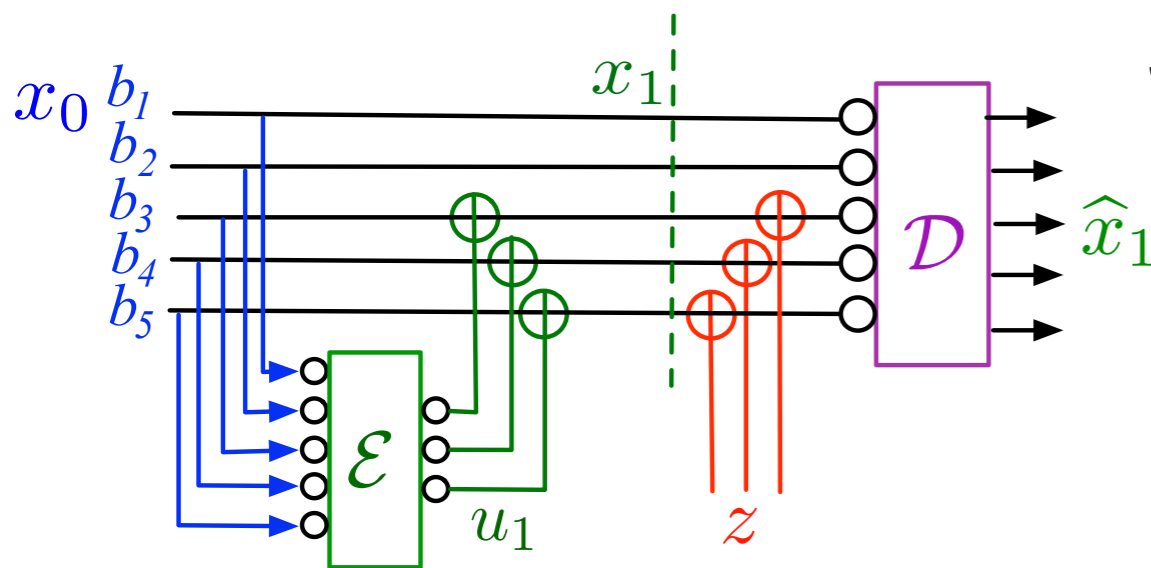

A semi-deterministic model

Strategies for “**signaling**”: quantization

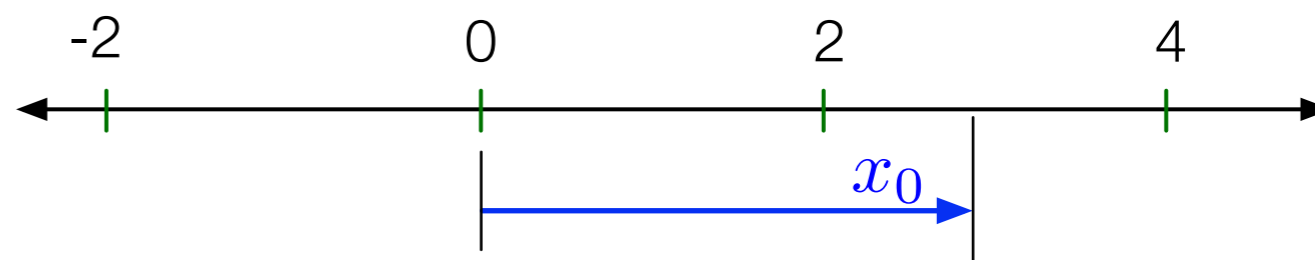

[Witsenhausen '68]

[Mitter, Sahai '99]

Witsenhausen's counterexample: a signaling perspective

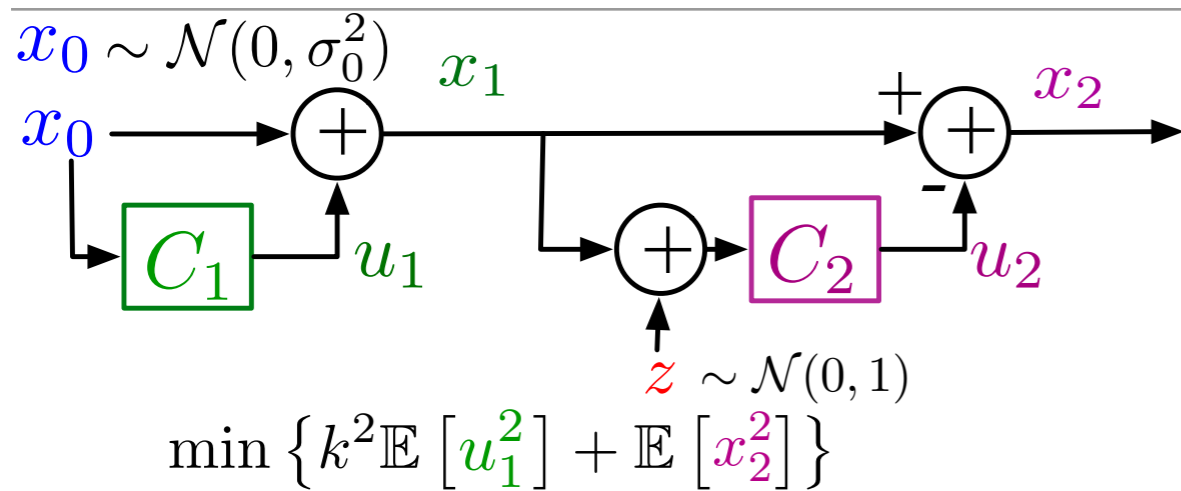

The counterexample

possibility of using **actions** to “signal”

[Ho, Kastner, Wong '78]

[Bansal, Başar '87]

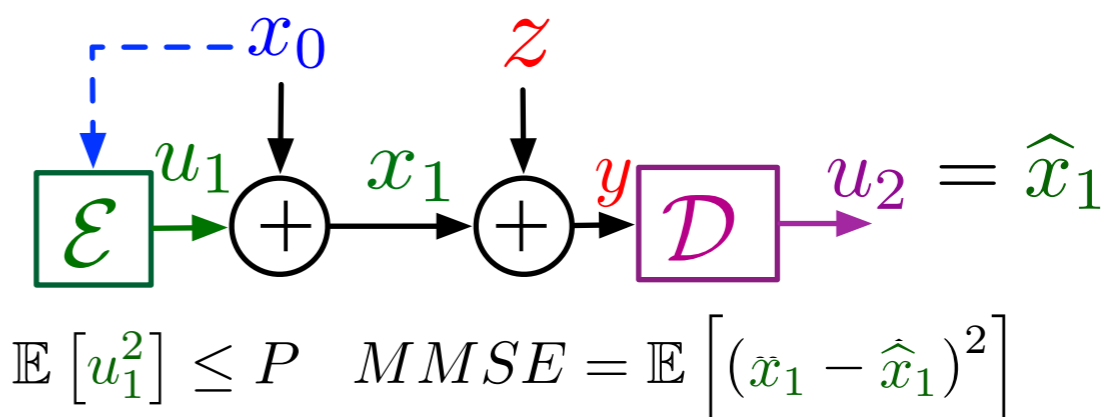

An information-theoretic interpretation

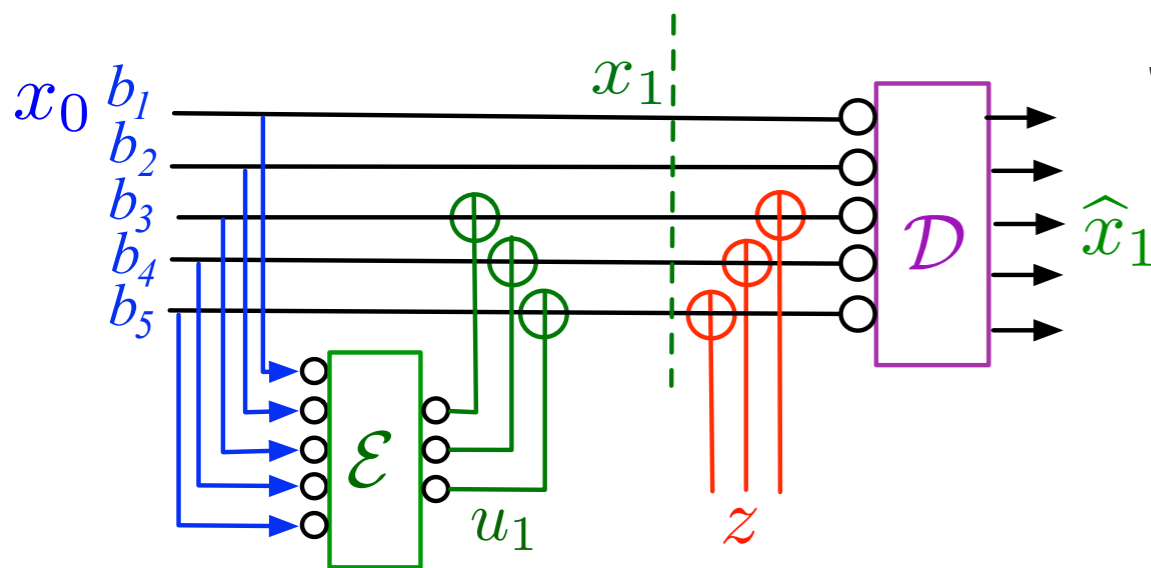

A semi-deterministic model

Strategies for “**signaling**”: quantization

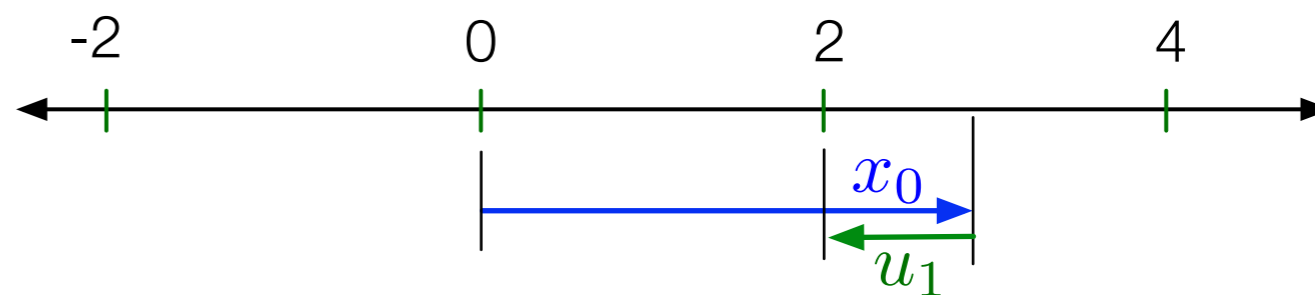

[Witsenhausen '68]

[Mitter, Sahai '99]

Witsenhausen's counterexample: a signaling perspective

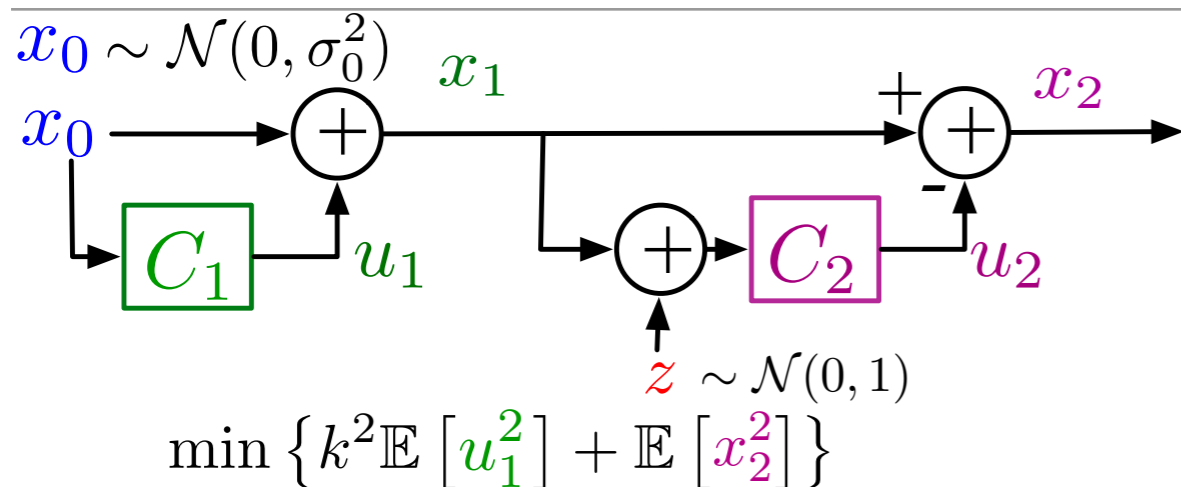

The counterexample

possibility of using **actions** to “signal”

[Ho, Kastner, Wong '78]

[Bansal, Başar '87]

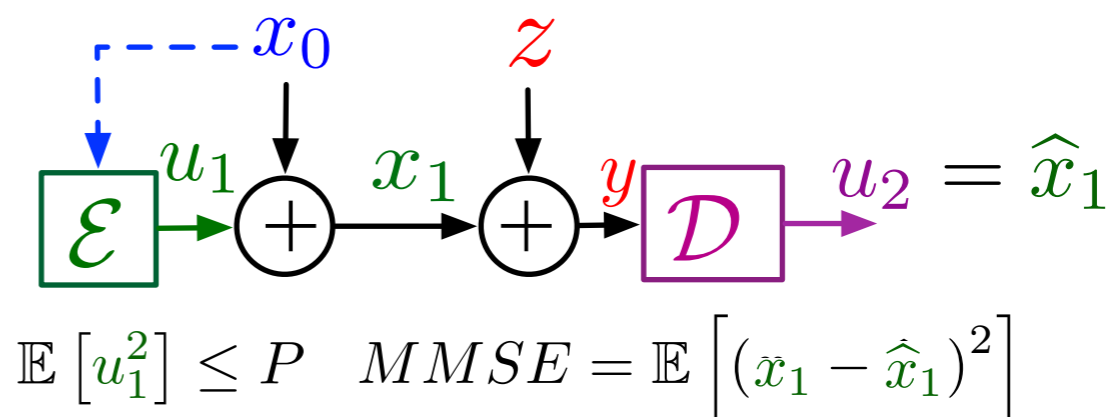

An information-theoretic interpretation

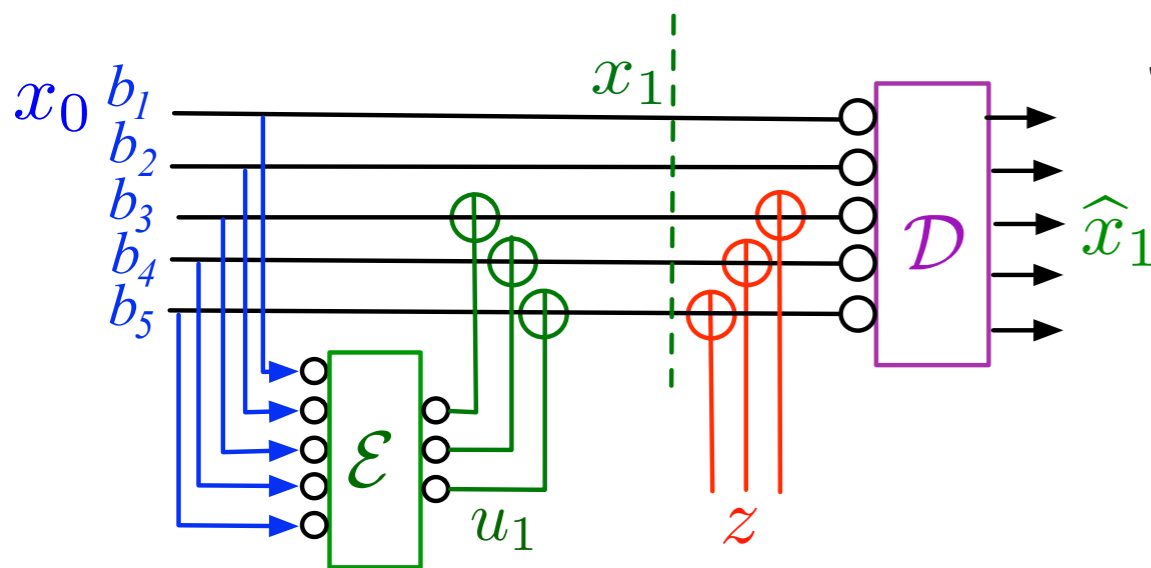

A semi-deterministic model

Strategies for “**signaling**”: quantization

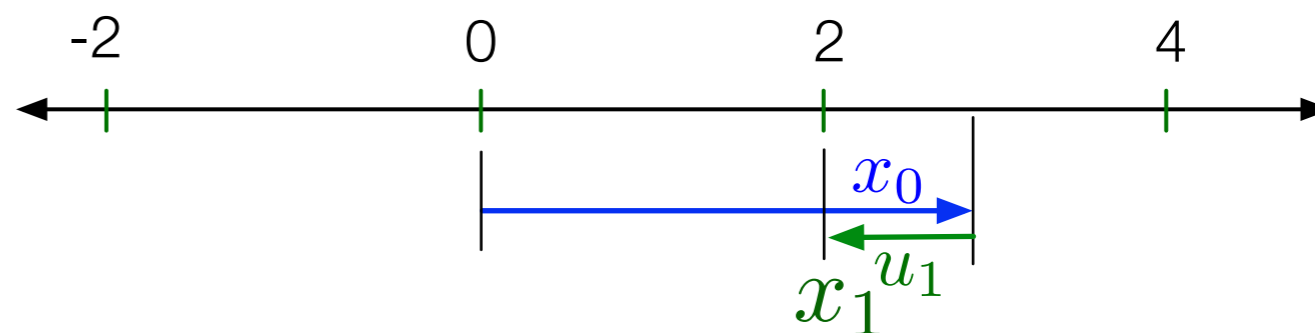

[Witsenhausen '68]

[Mitter, Sahai '99]

Approximately-optimal solutions to Witsenhausen's counterexample

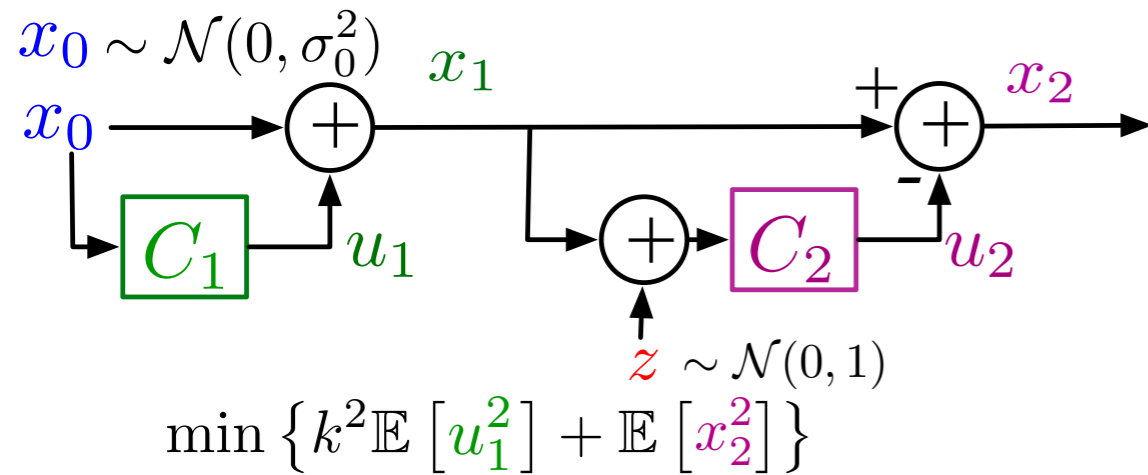

Approximately-optimal solutions to Witsenhausen's counterexample

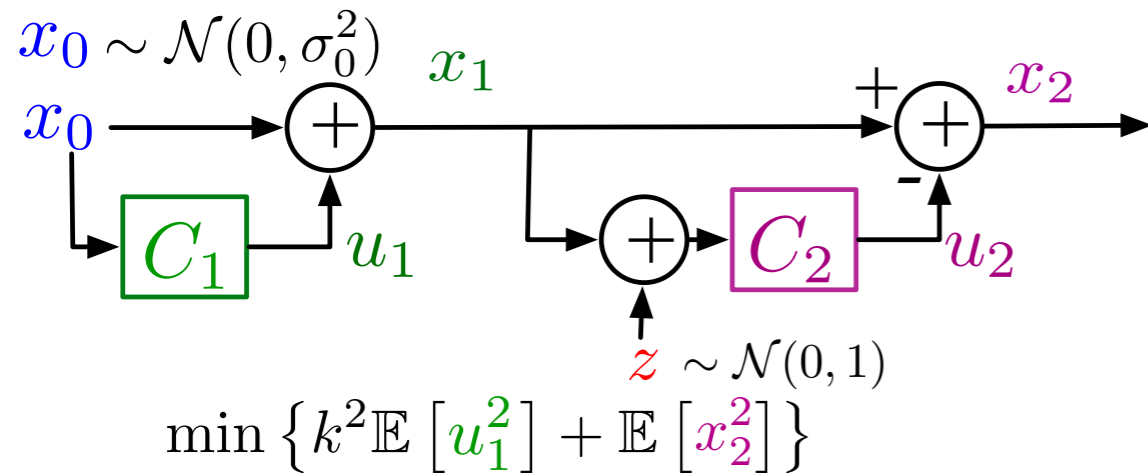

Information-theoretic [lower bound](#)
on costs for “signaling”
[\[Grover, Park, Sahai '09\]](#)

Approximately-optimal solutions to Witsenhausen's counterexample

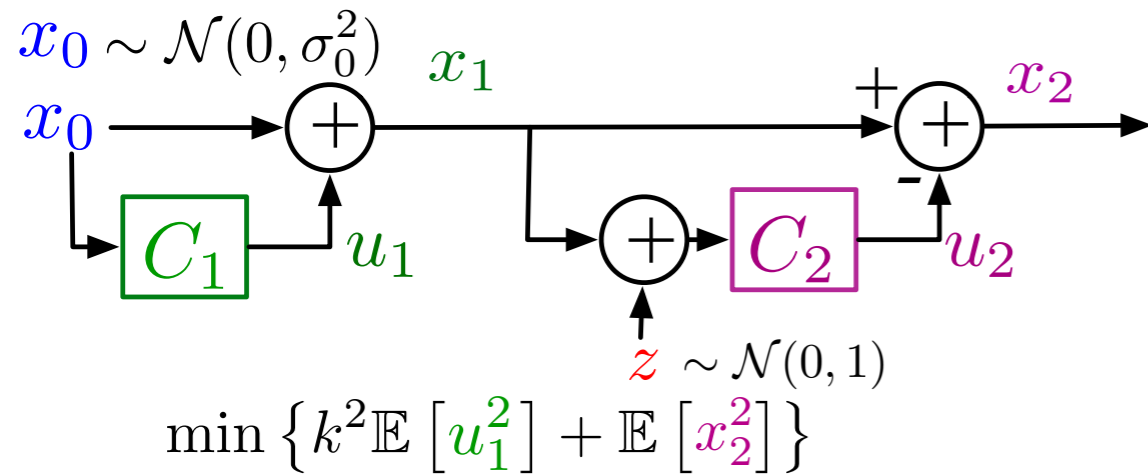

Information-theoretic lower bound on costs for “signaling”
 [Grover, Park, Sahai '09]

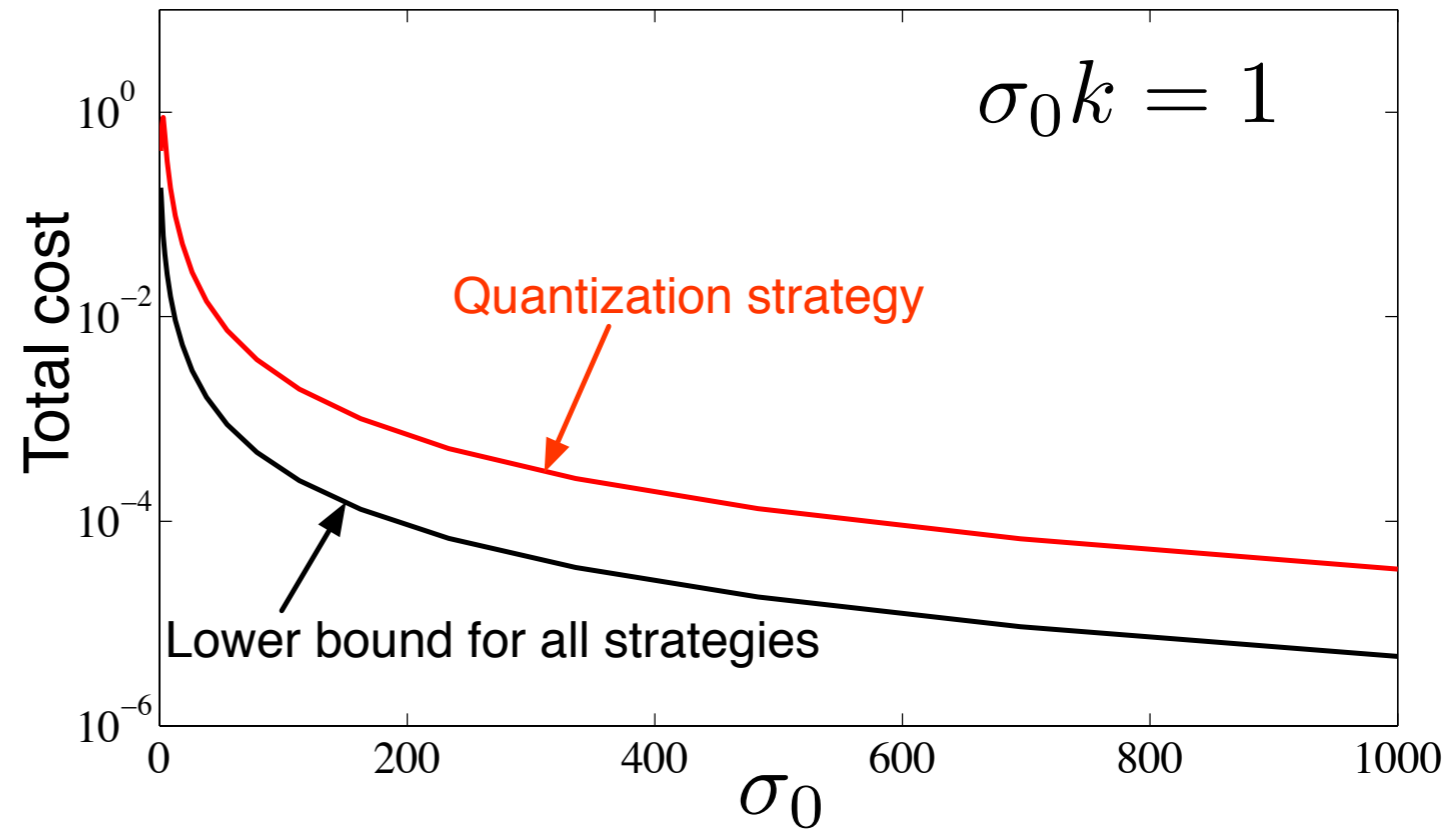

Approximately-optimal solutions to Witsenhausen's counterexample

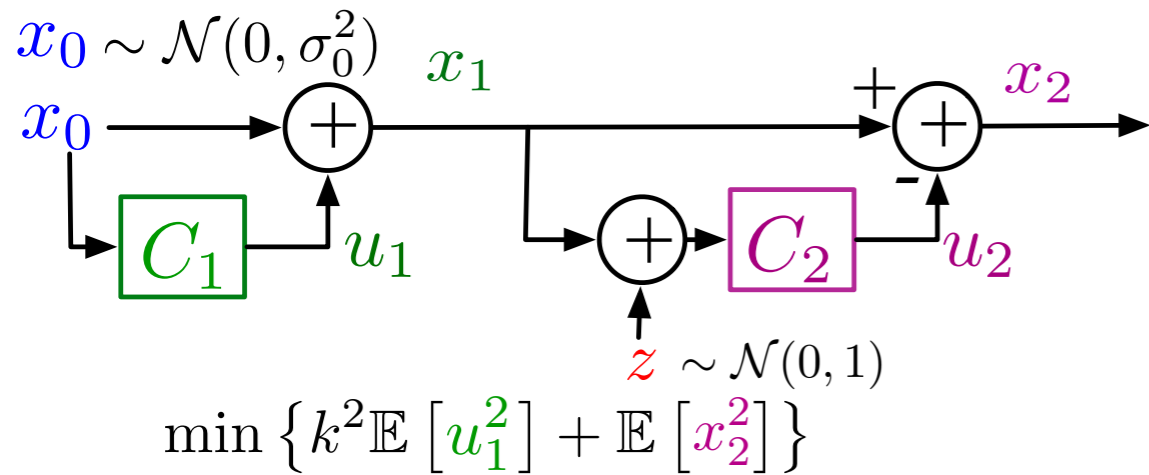

Information-theoretic lower bound on costs for “signaling” [Grover, Park, Sahai '09]

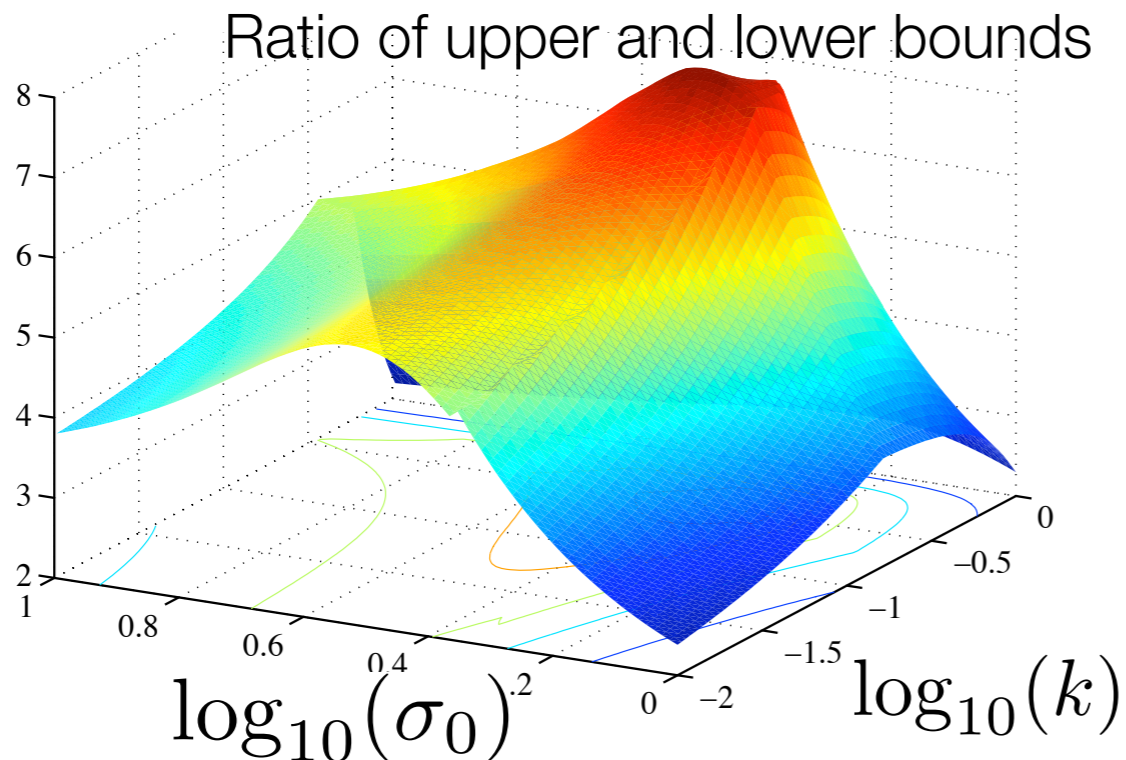
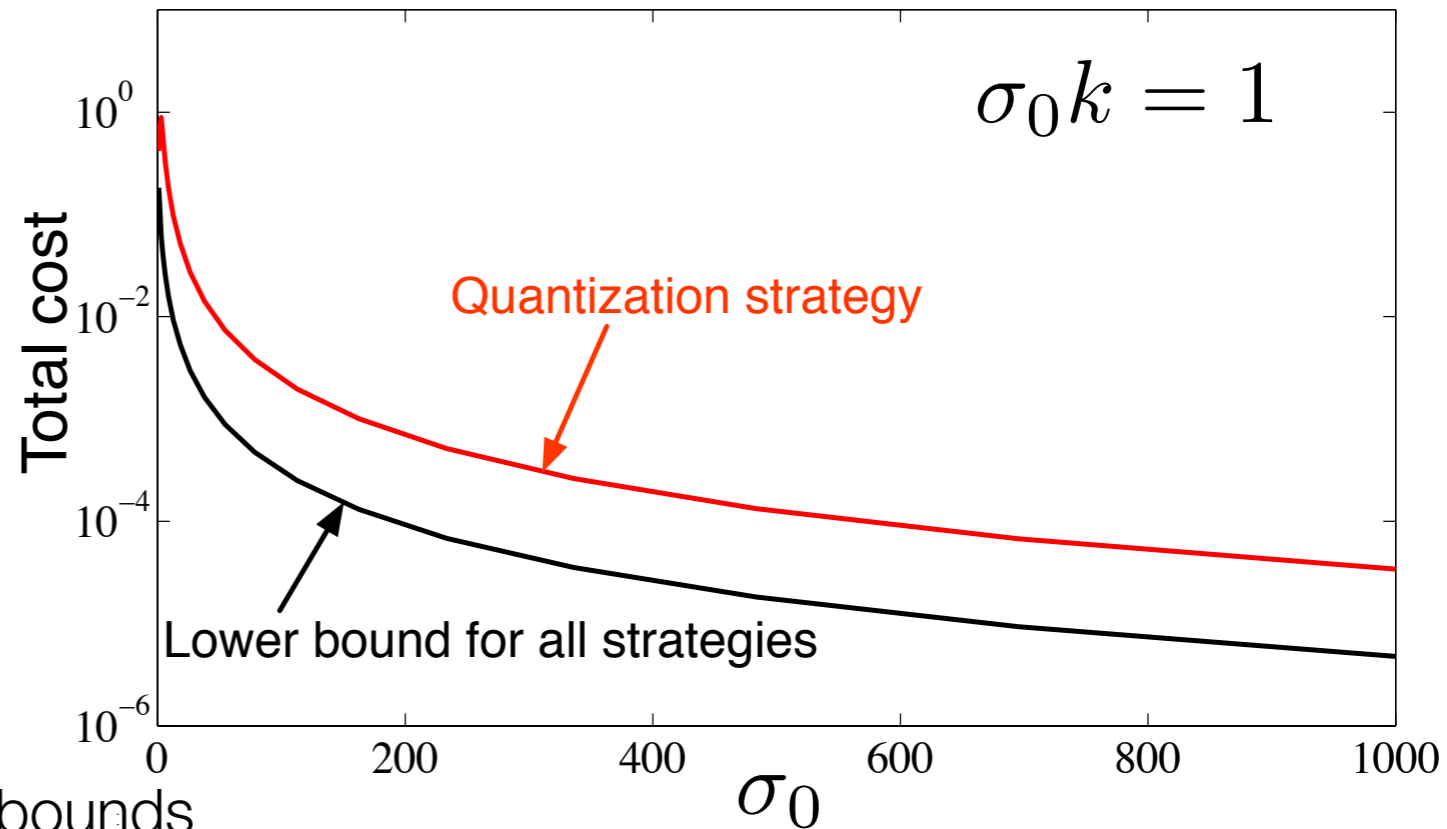

Approximately-optimal solutions to Witsenhausen's counterexample

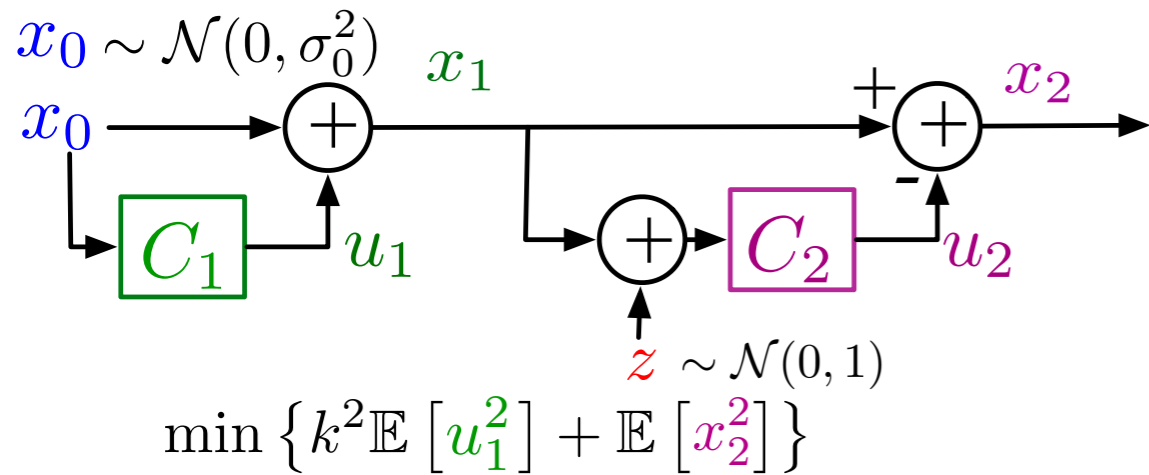

Information-theoretic lower bound on costs for “signaling” [Grover, Park, Sahai '09]

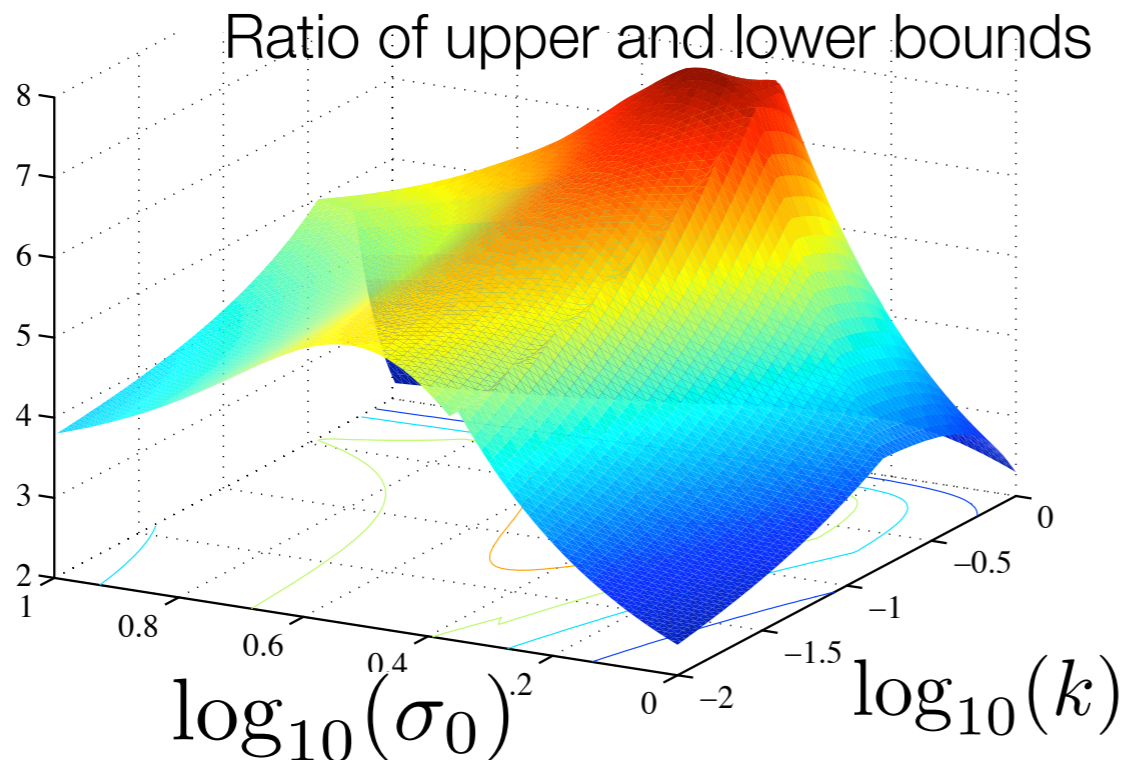
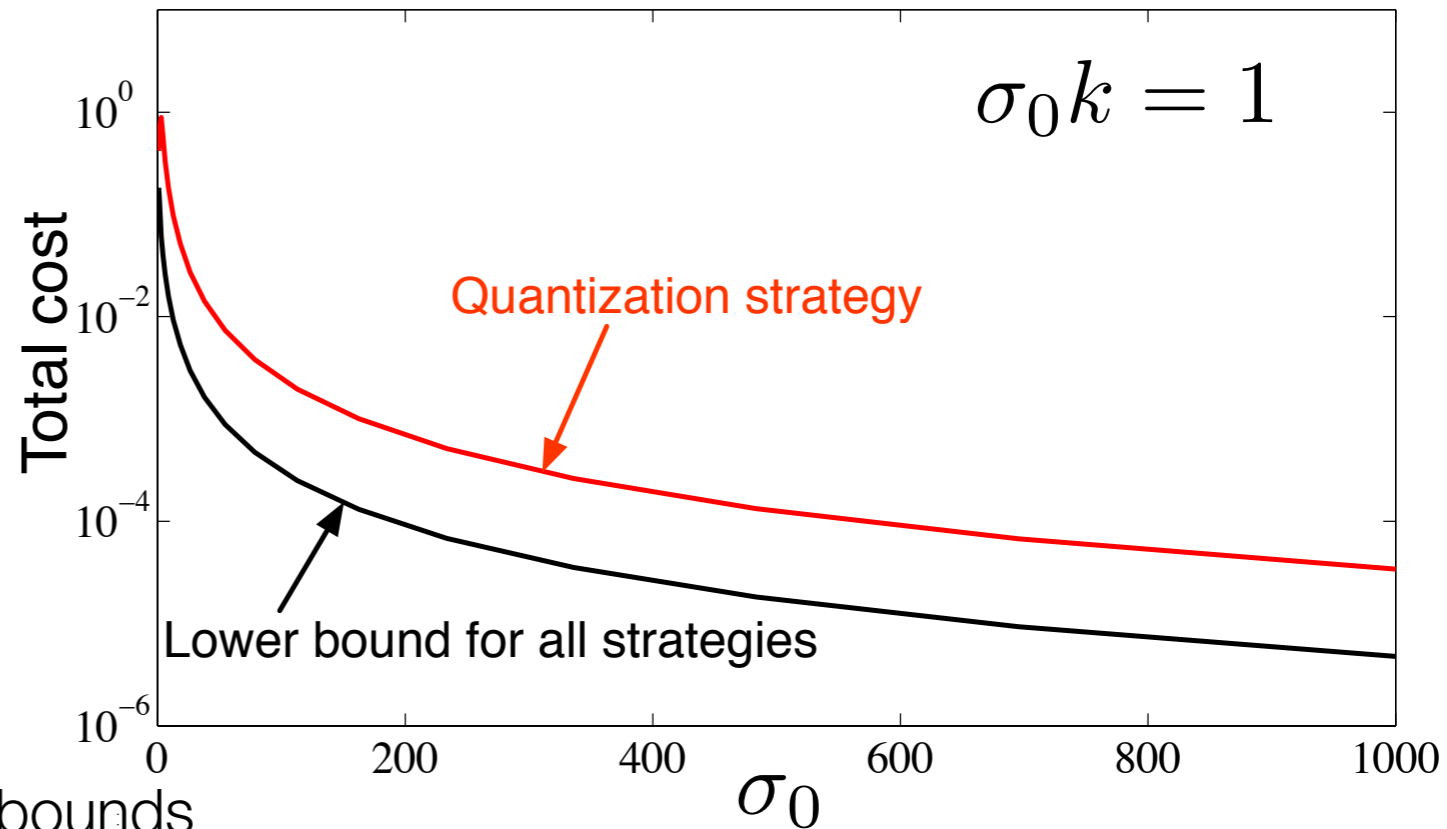

Within a factor of 8 of optimal cost for all (k, σ_0)

Is the counterexample **relevant**? Part I

Just connect them using an external channel!

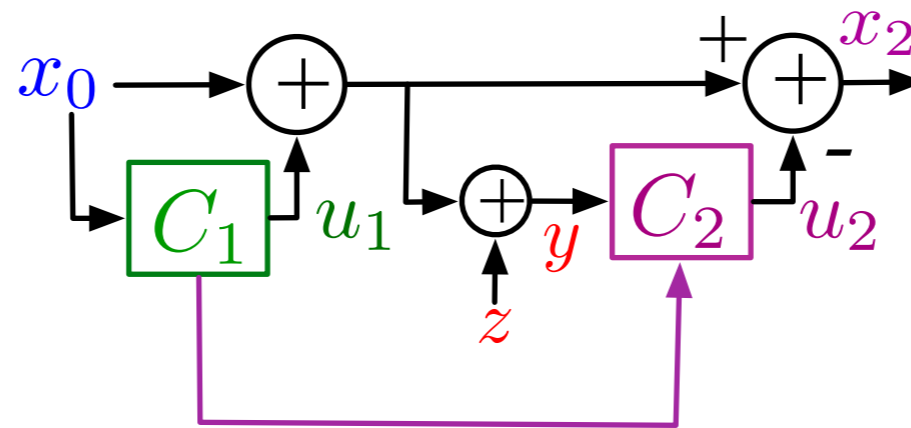

Is the counterexample **relevant**? Part I

Just connect them using an external channel!

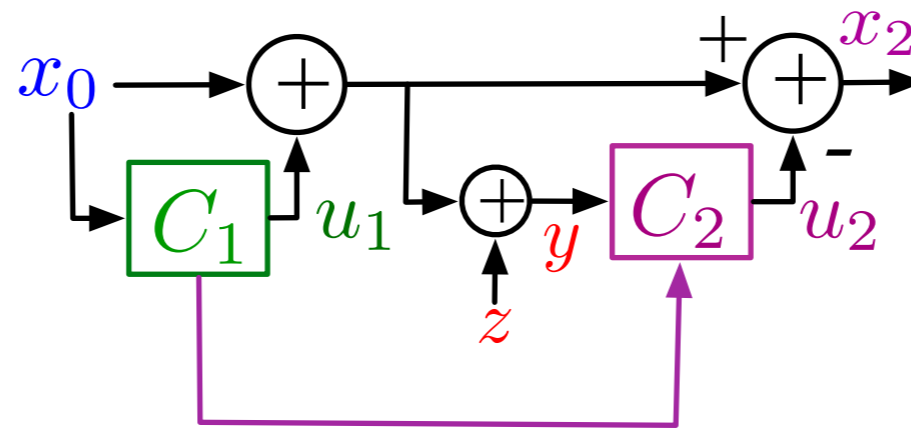

partial-nestedness [Ho, Chu '72]

Is the counterexample **relevant**? Part I

Just connect them using an external channel!

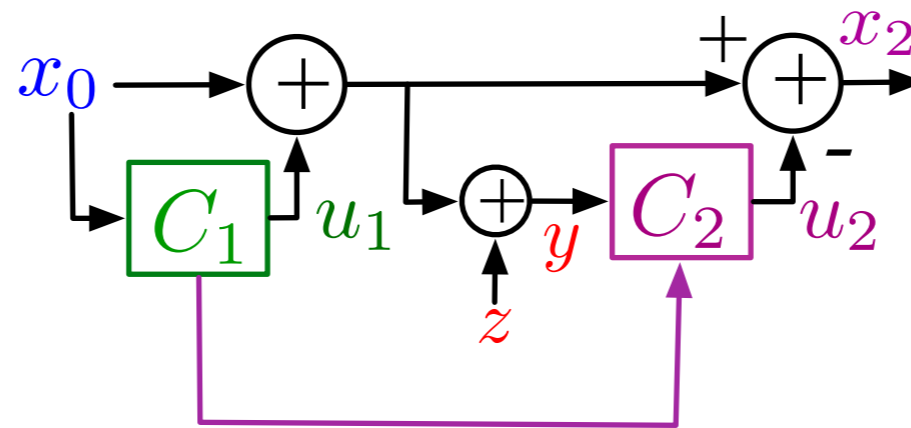

partial-nestedness [Ho, Chu '72]

quadratic-invariance [Rotkowitz, Lall '06]

Is the counterexample **relevant**? Part I

Just connect them using an external channel!

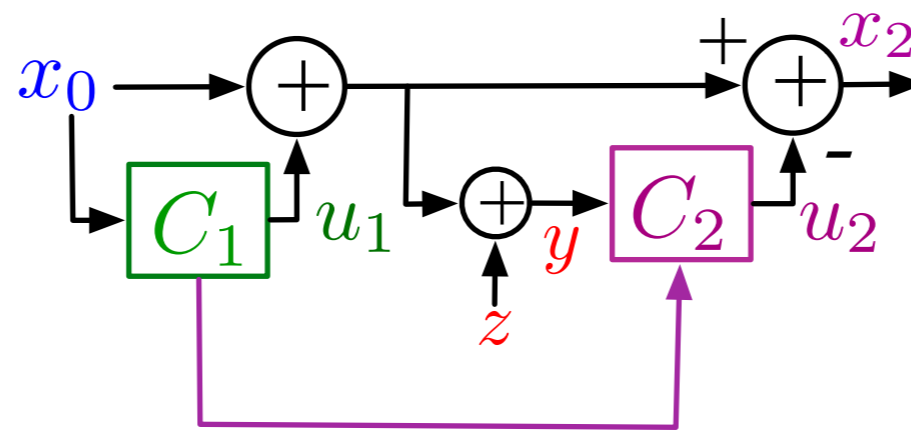

partial-nestedness [Ho, Chu '72]

quadratic-invariance [Rotkowitz, Lall '06]

Q1. Why should we use actions for signaling?

[John Doyle, "Paths ahead", MIT, 2009]

A **realistic** external channel has finite capacity!

A **realistic** external channel has finite capacity!

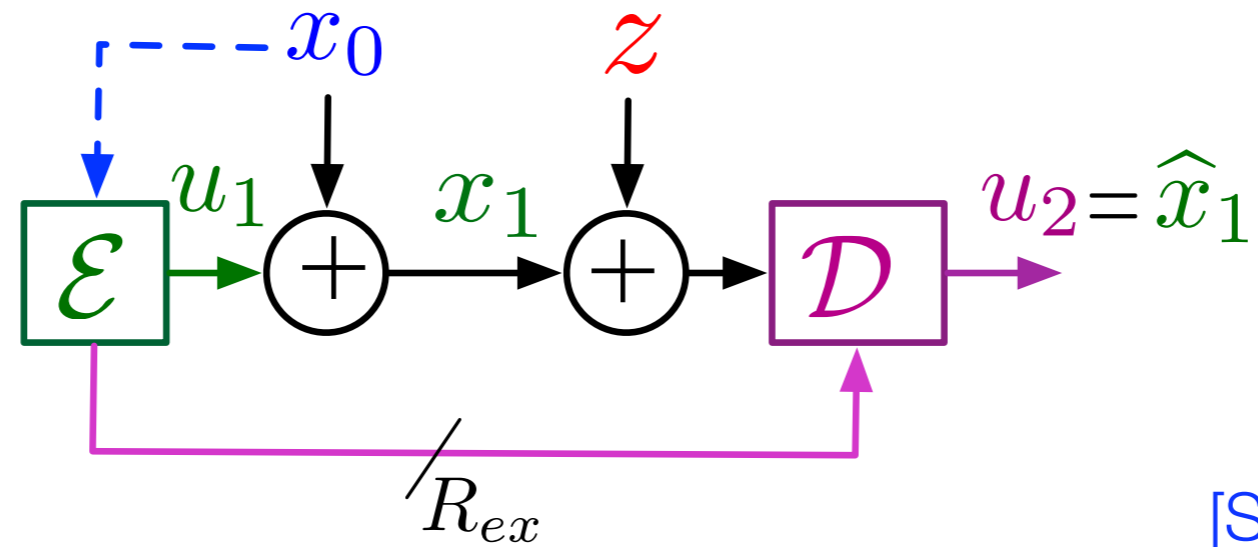

[Shoarinejad '02]
[Martins '06]

A **realistic** external channel has finite capacity!

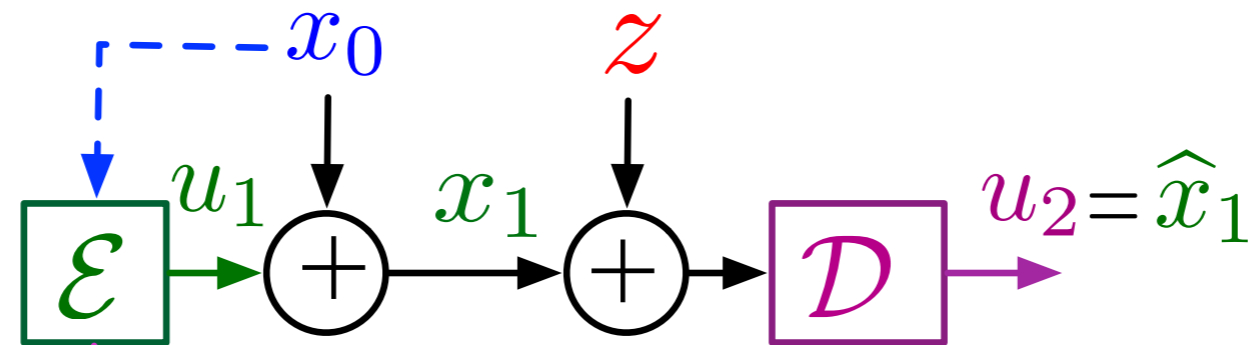

[Shoarinejad '02]
[Martins '06]

A **realistic** external channel has finite capacity!

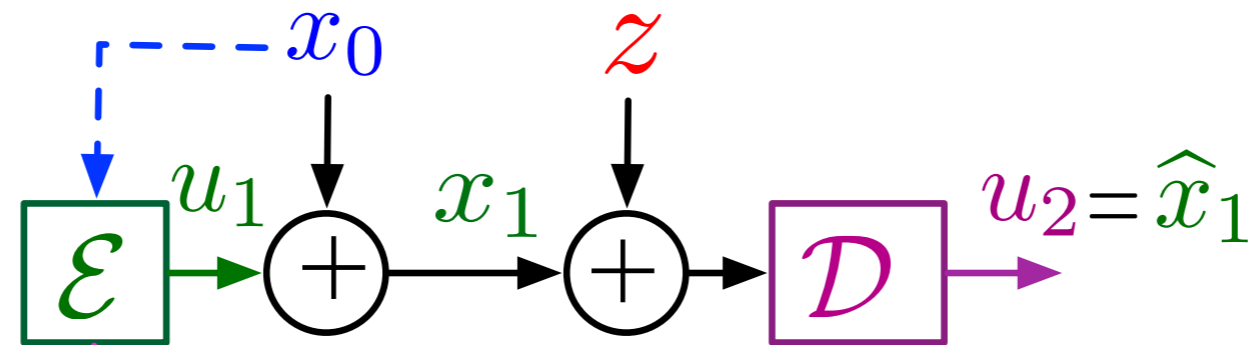

[Shoarinejad '02]
[Martins '06]

Actions : quantize

A **realistic** external channel has finite capacity!

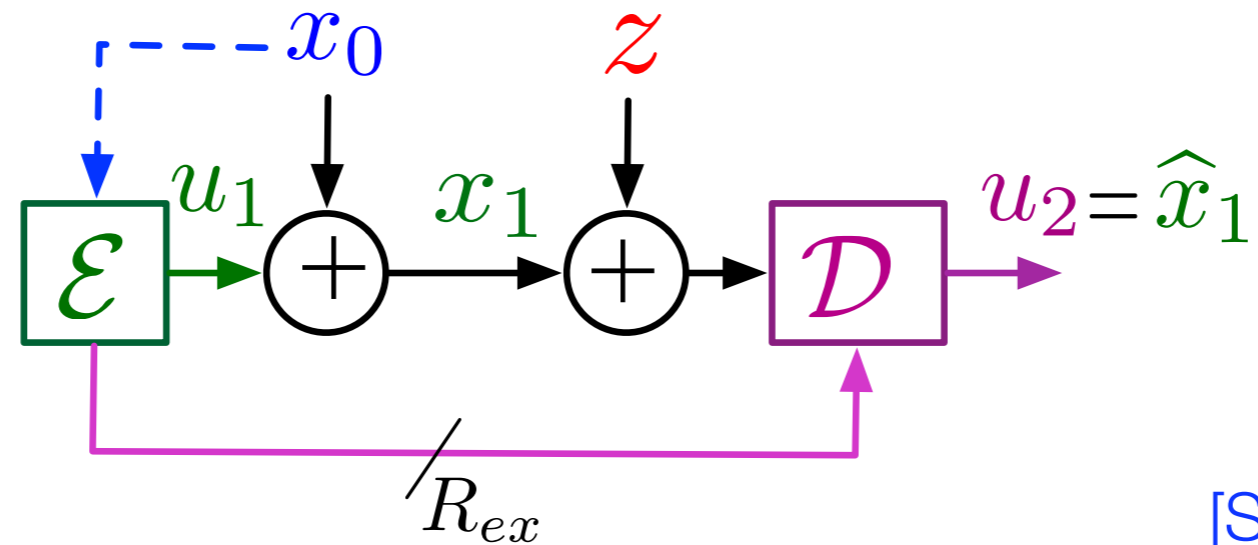

[Shoarinejad '02]
[Martins '06]

Actions : quantize

A **realistic** external channel has finite capacity!

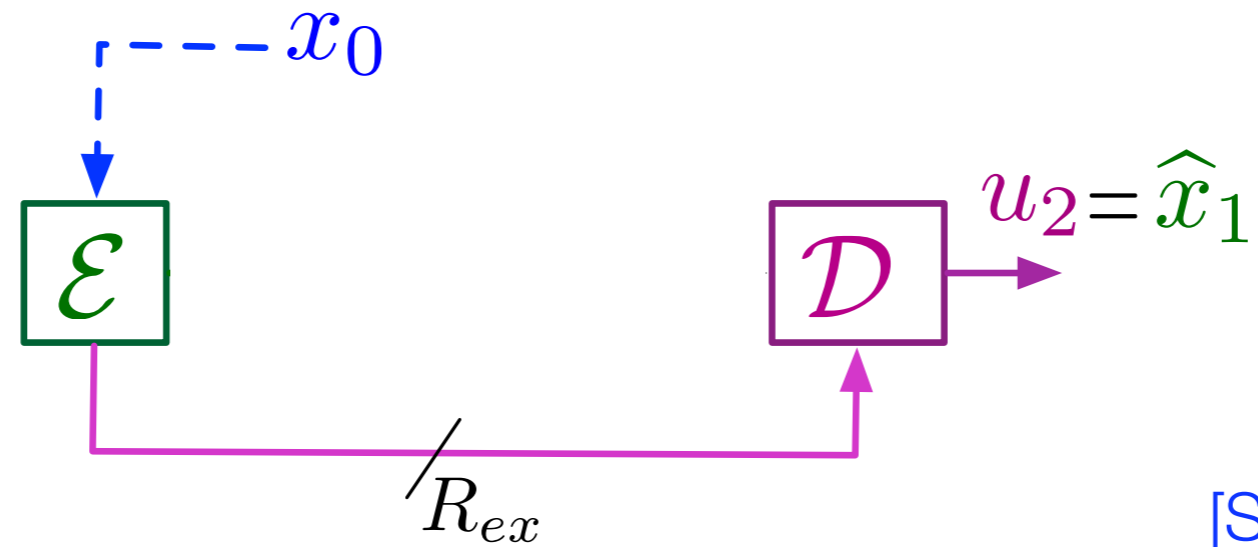

[Shoarinejad '02]
[Martins '06]

Actions : quantize

A **realistic** external channel has finite capacity!

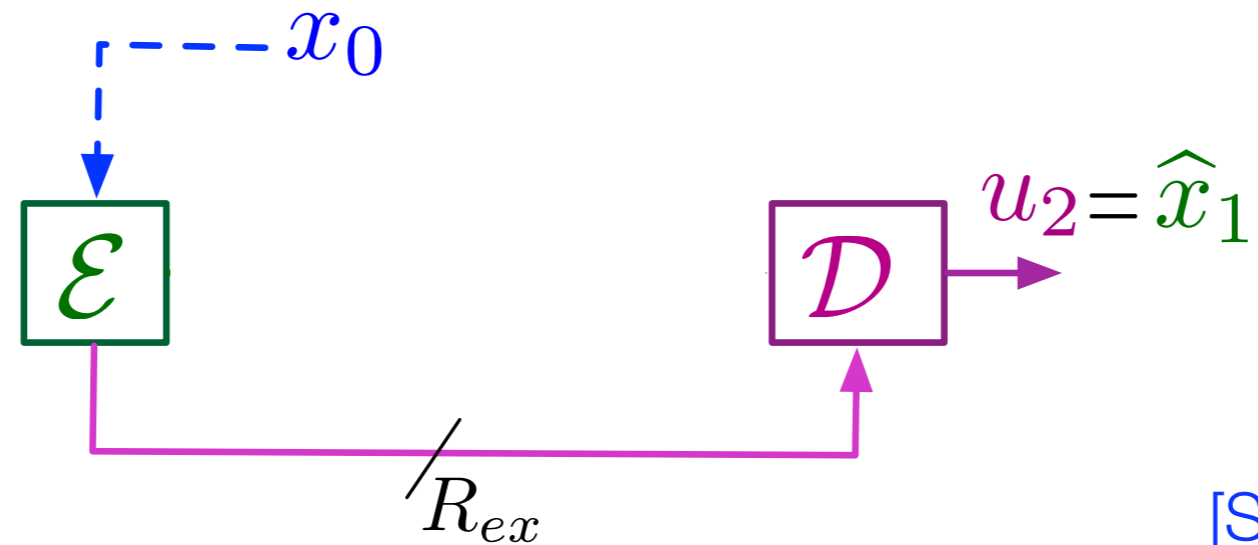

[Shoarinejad '02]
[Martins '06]

Actions : quantize

External channel : linear

A **realistic** external channel has finite capacity!

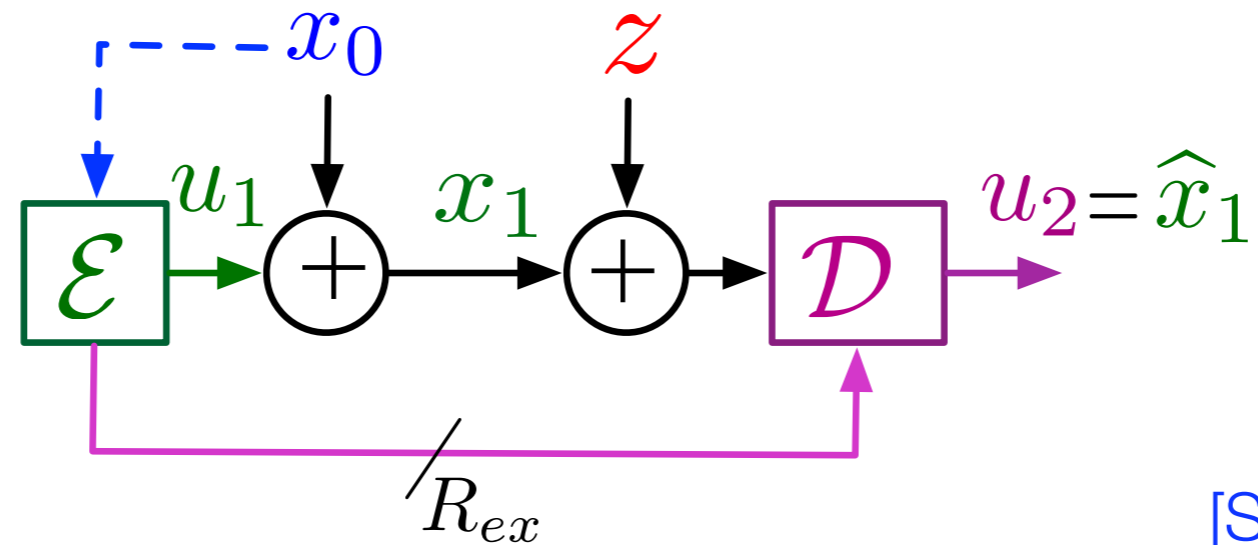

[Shoarinejad '02]
[Martins '06]

Actions : quantize

External channel : linear

A **realistic** external channel has finite capacity!

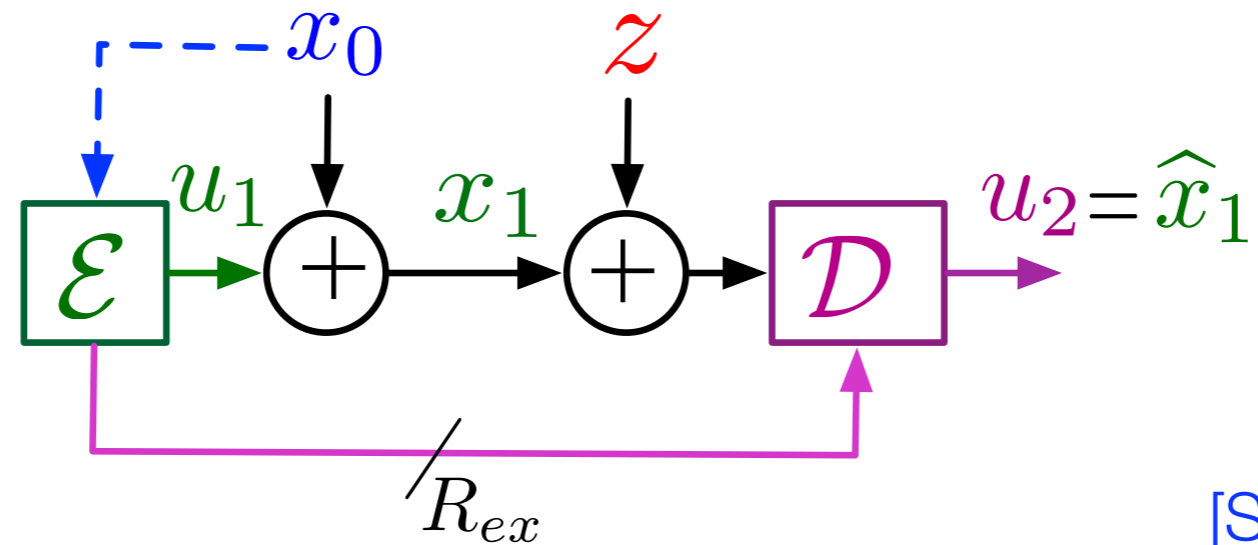

[Shoarinejad '02]
[Martins '06]

[Martins '06]

Actions : quantize

External channel : linear

A **realistic** external channel has finite capacity!

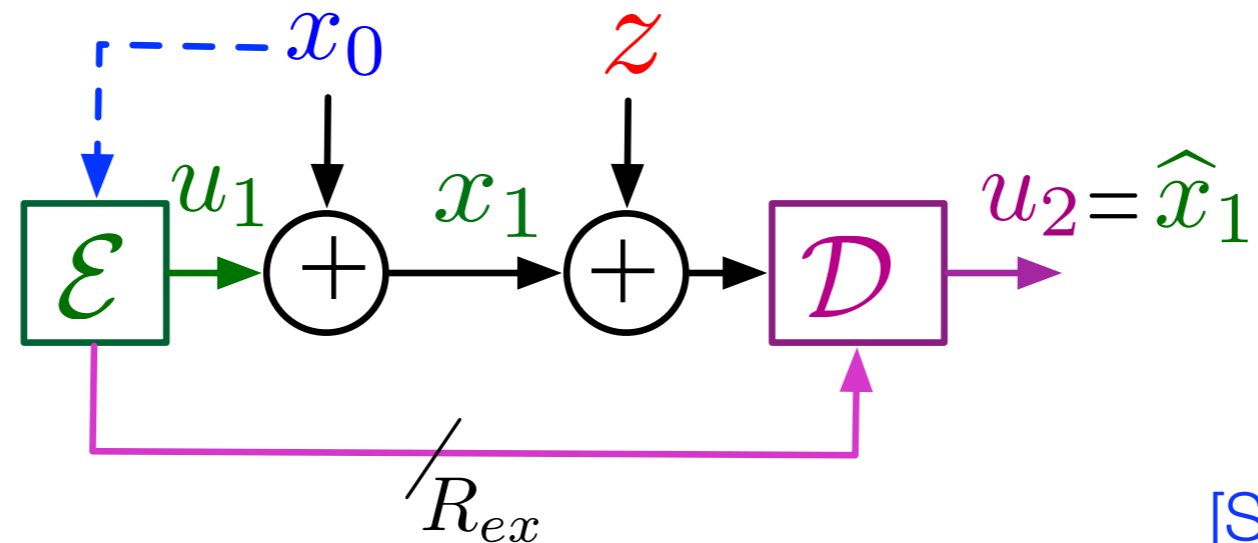

[Shoarinejad '02]
[Martins '06]

[Martins '06]

Actions : quantize

External channel : linear

Outperforms linear strategies even at high R_{ex}

A **realistic** external channel has finite capacity!

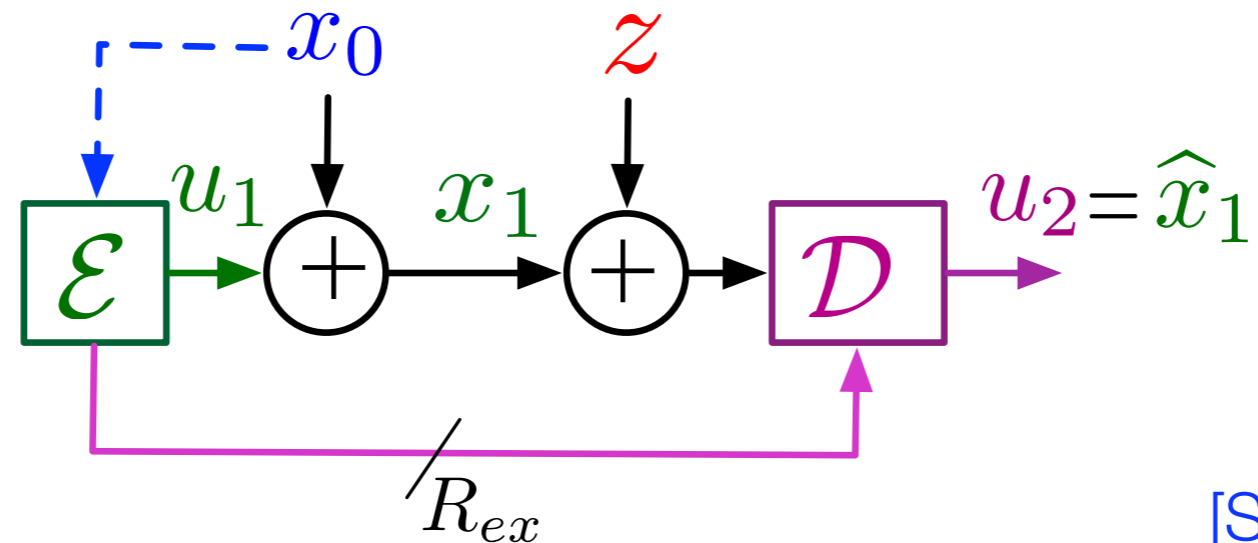

[Shoarinejad '02]
[Martins '06]

[Martins '06]

Actions : quantize

External channel : linear

Outperforms linear strategies even at high R_{ex}

“most-significant bits” through the plant

A **realistic** external channel has finite capacity!

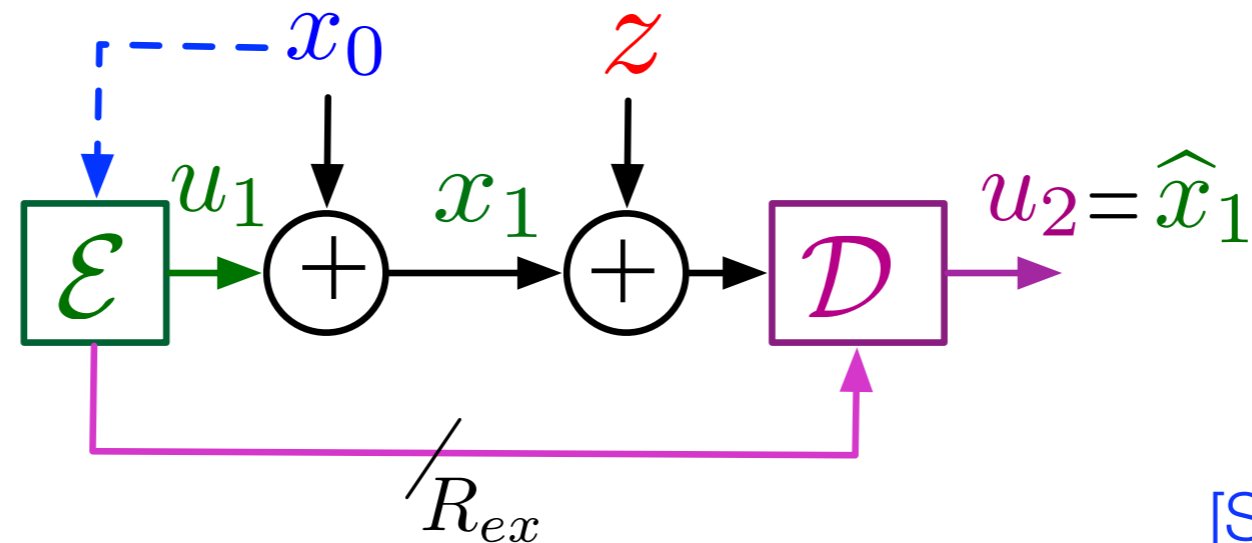

[Shoarinejad '02]
[Martins '06]

[Martins '06]

Actions : quantize

External channel : linear

Outperforms linear strategies even at high R_{ex}

“most-significant bits” through the plant

“most significant bits” also through the external channel

A **realistic** external channel has finite capacity!

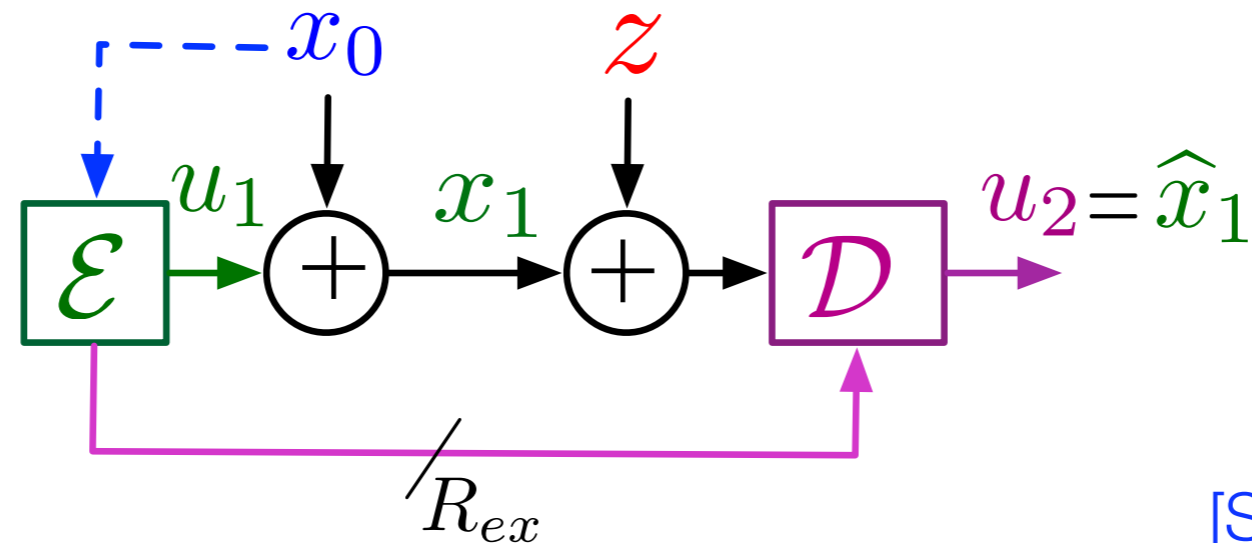

[Shoarinejad '02]
[Martins '06]

[Martins '06]

Actions : quantize

External channel : linear

Outperforms linear strategies even at high R_{ex}

“most-significant bits” through the plant

“most significant bits” also through the external channel : **redundant!**

A semi-deterministic model

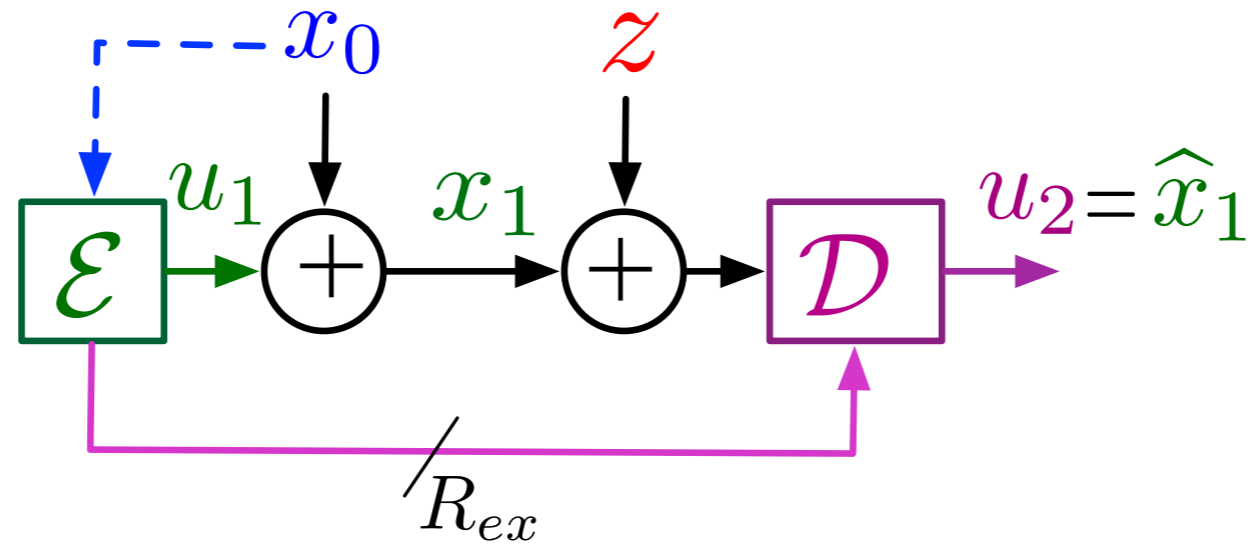

[Grover, Sahai '10]

A semi-deterministic model

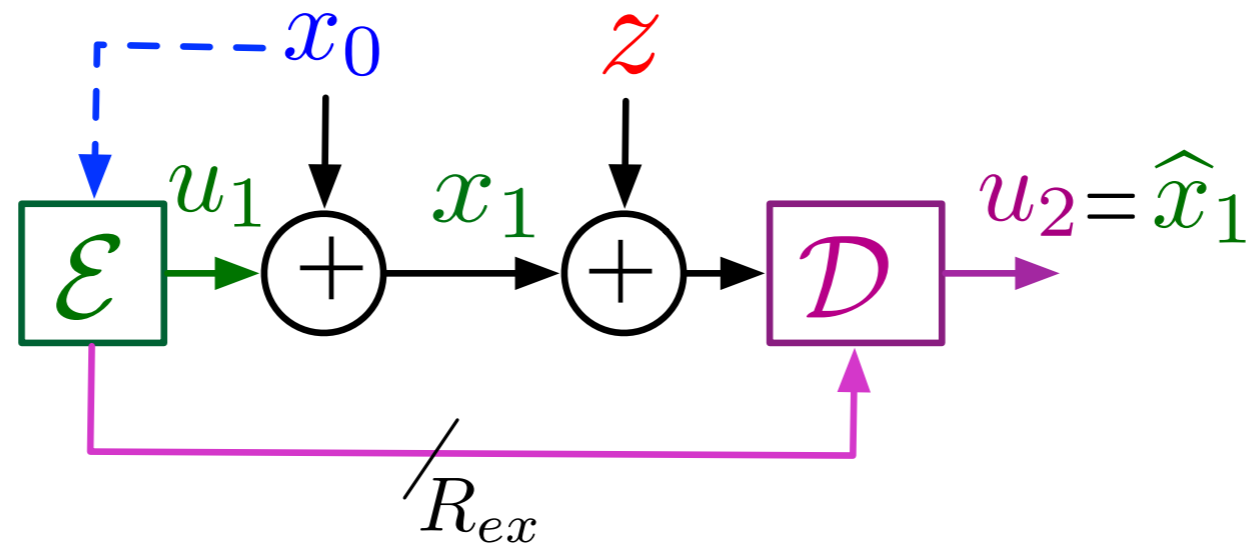

x_0 b_1
 b_2
 b_3
 b_4
 b_5

[Grover, Sahai '10]

A semi-deterministic model

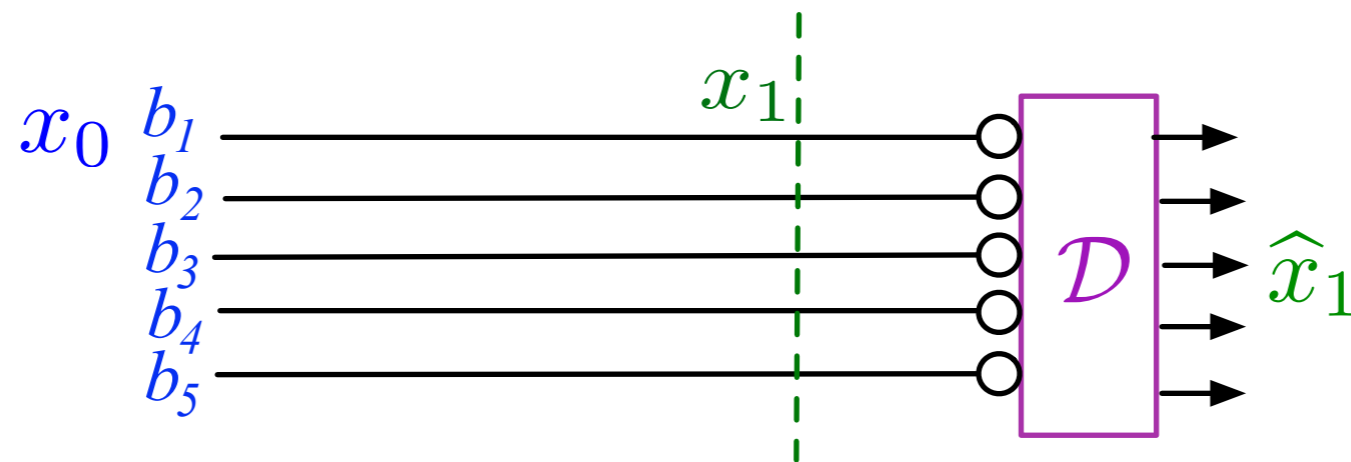
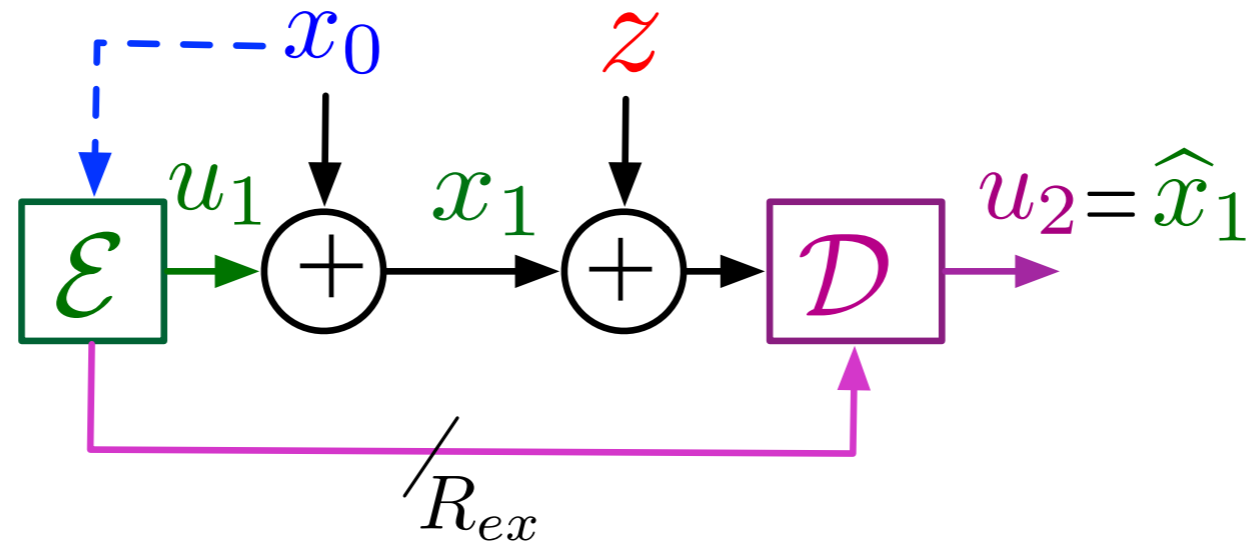

[Grover, Sahai '10]

A semi-deterministic model

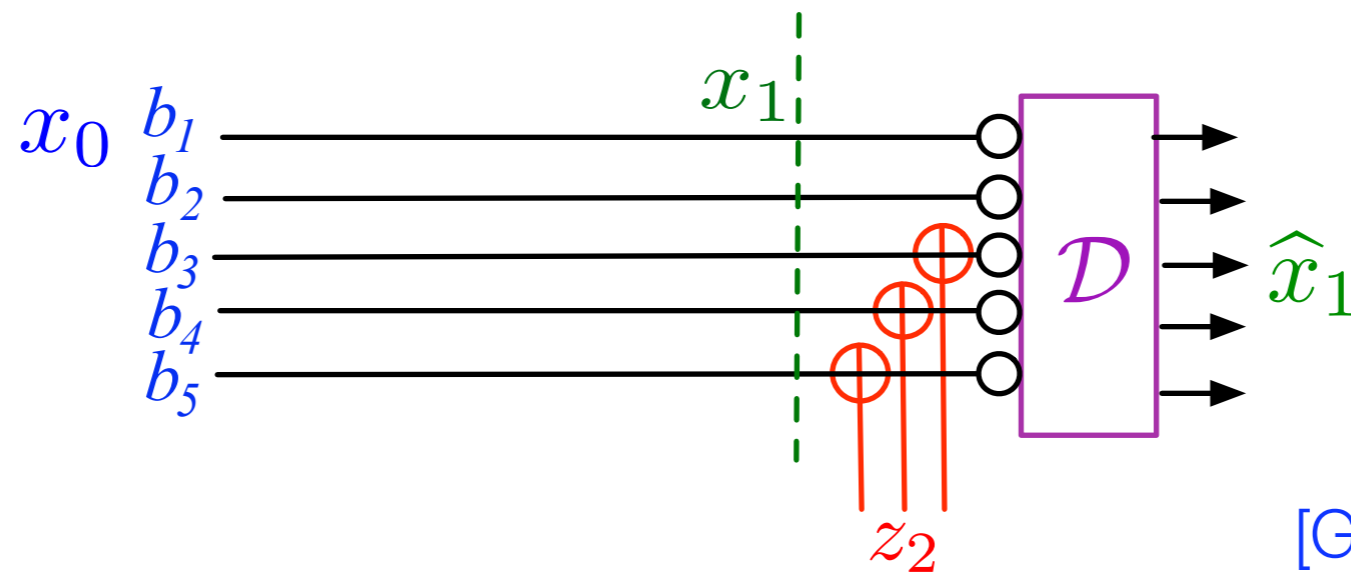
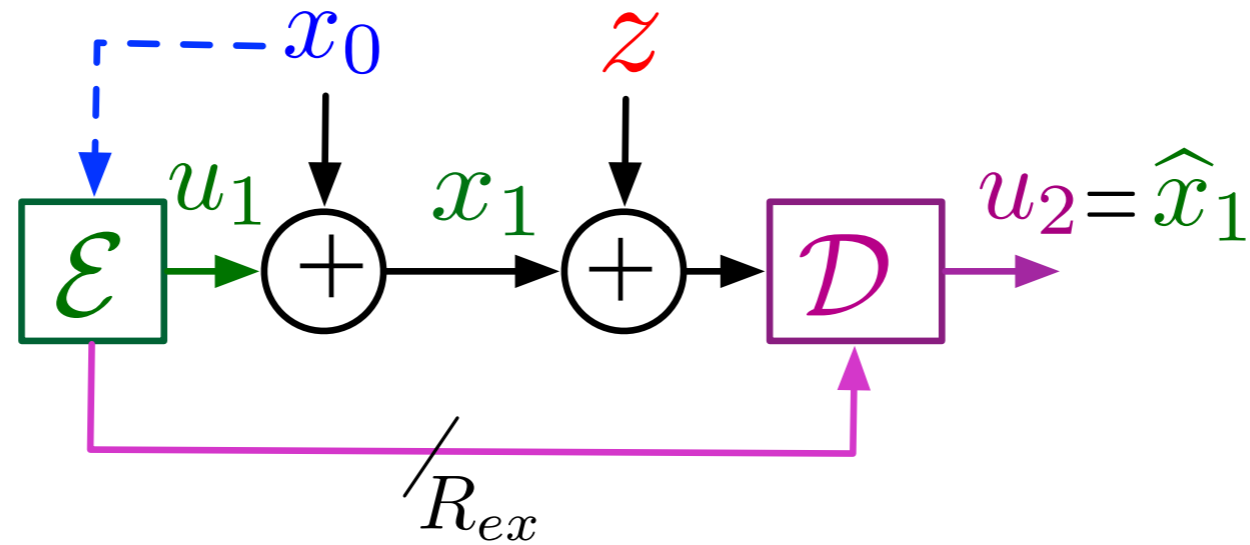

[Grover, Sahai '10]

A semi-deterministic model

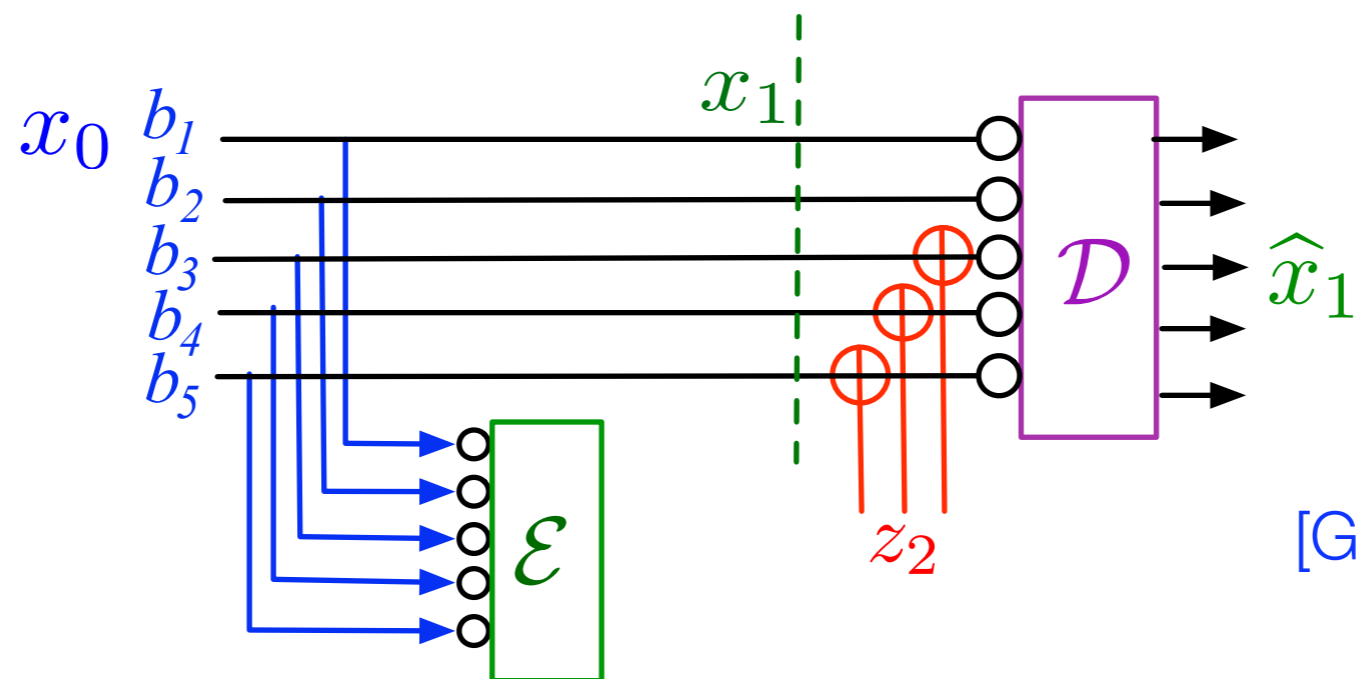
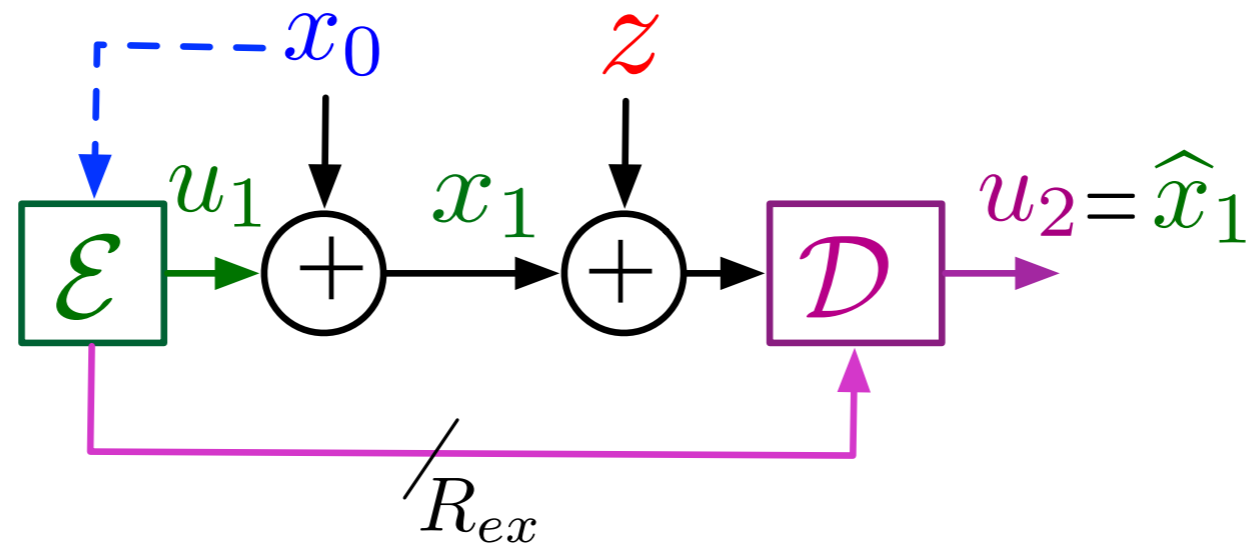

[Grover, Sahai '10]

A semi-deterministic model

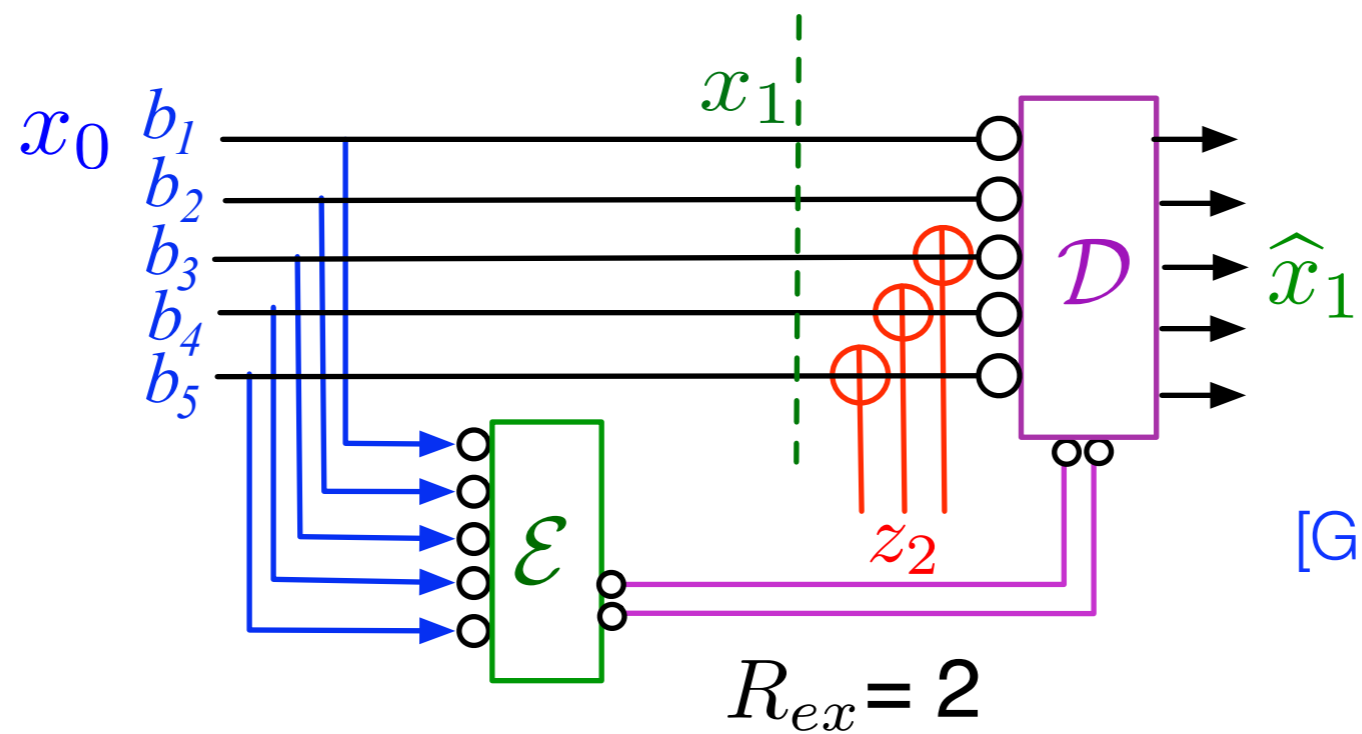
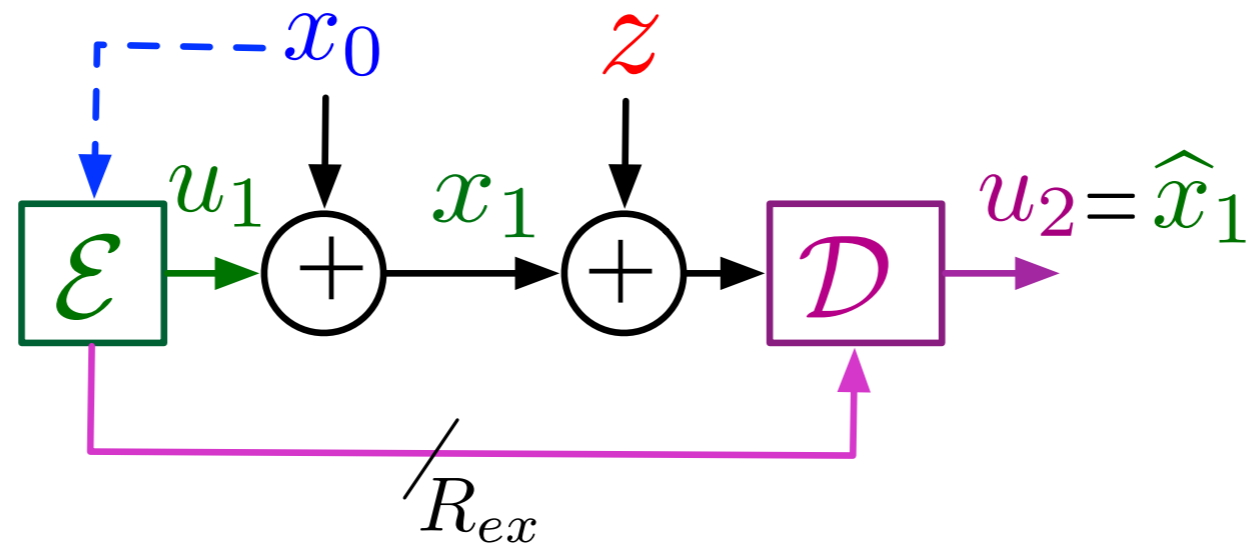

[Grover, Sahai '10]

A semi-deterministic model

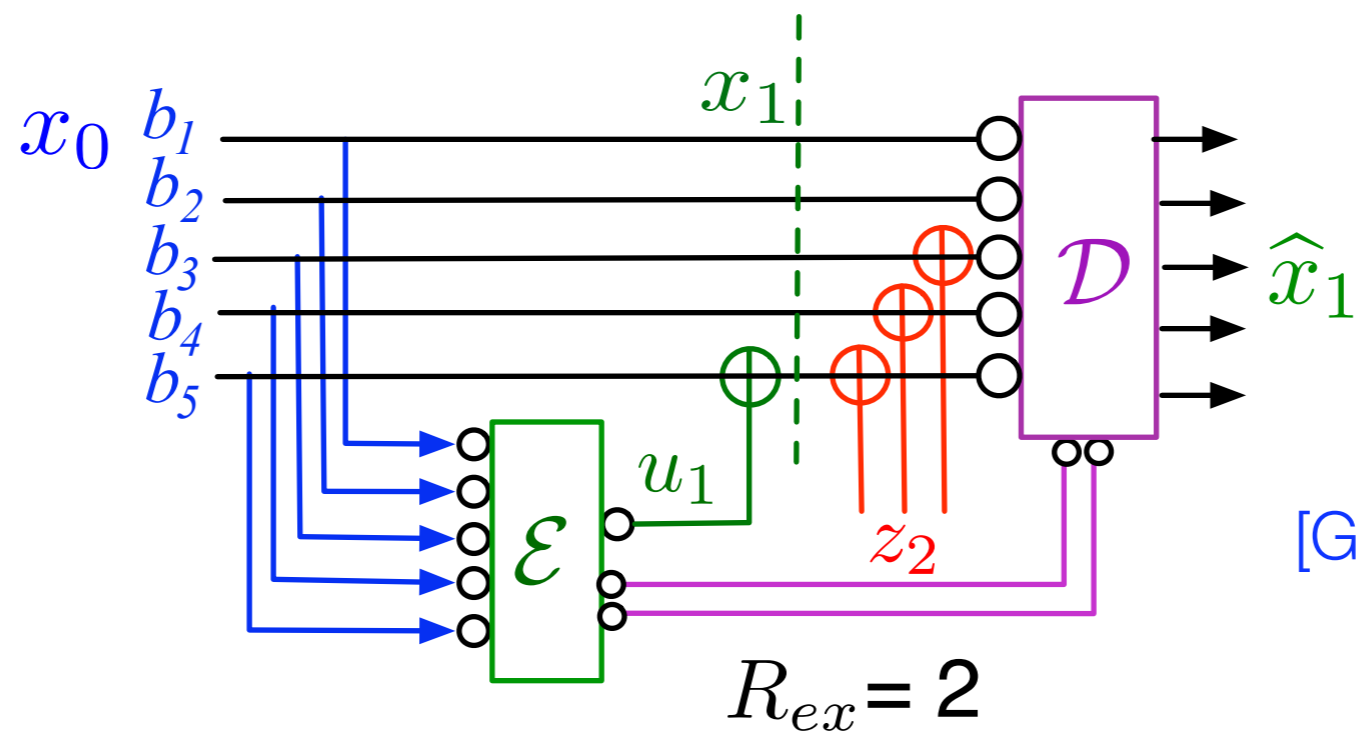
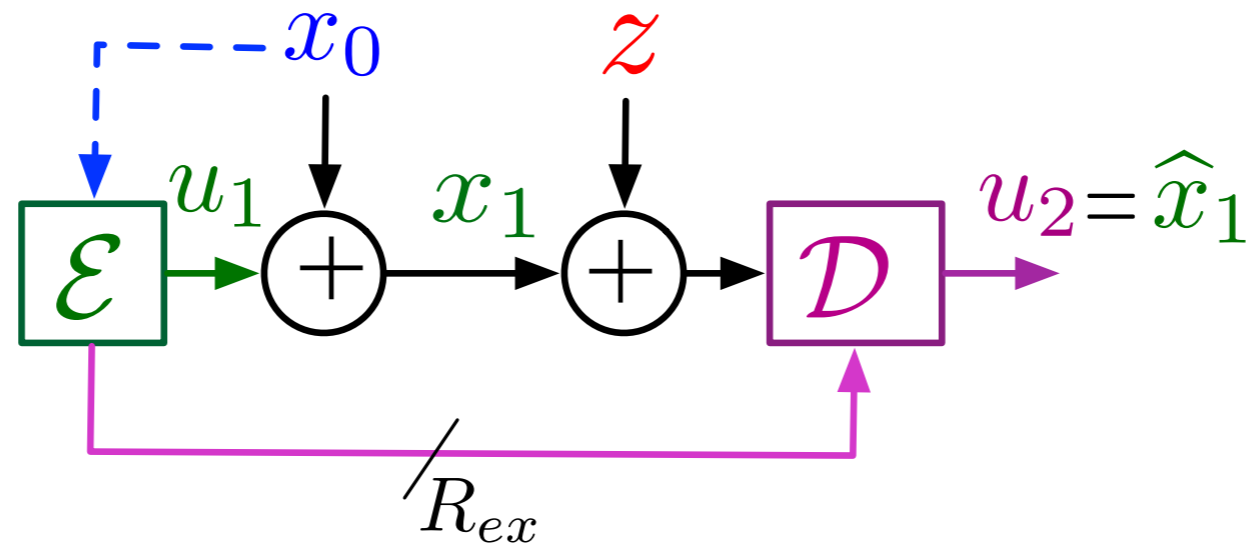

[Grover, Sahai '10]

More efficient: think “parallel channels”!

[Grover, Sahai '10]

More efficient: think “parallel channels”!

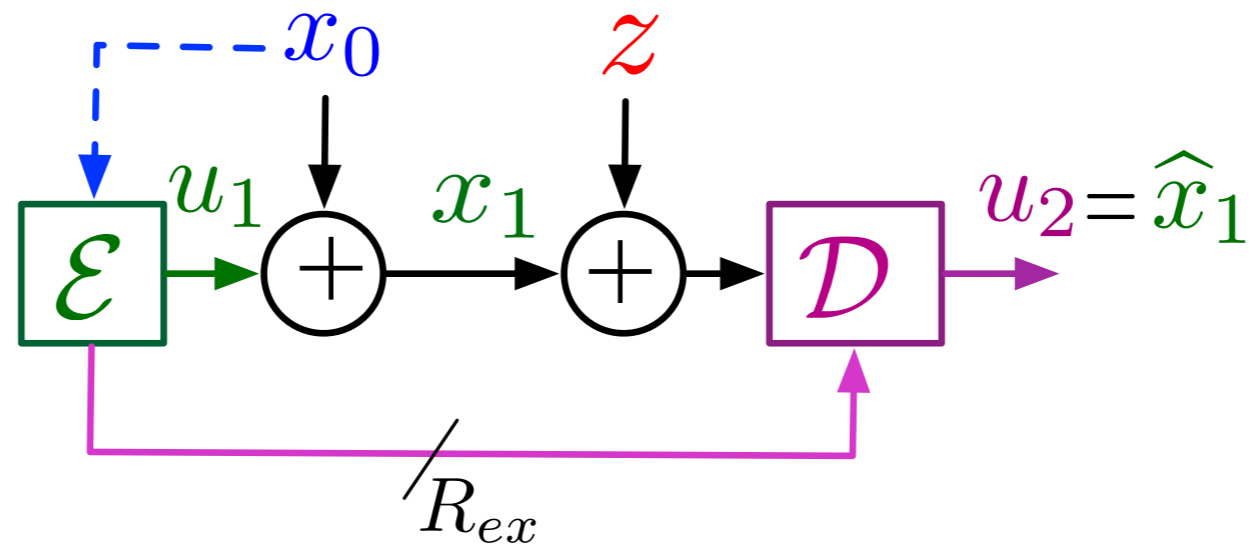

[Grover, Sahai '10]

More efficient: think “parallel channels”!

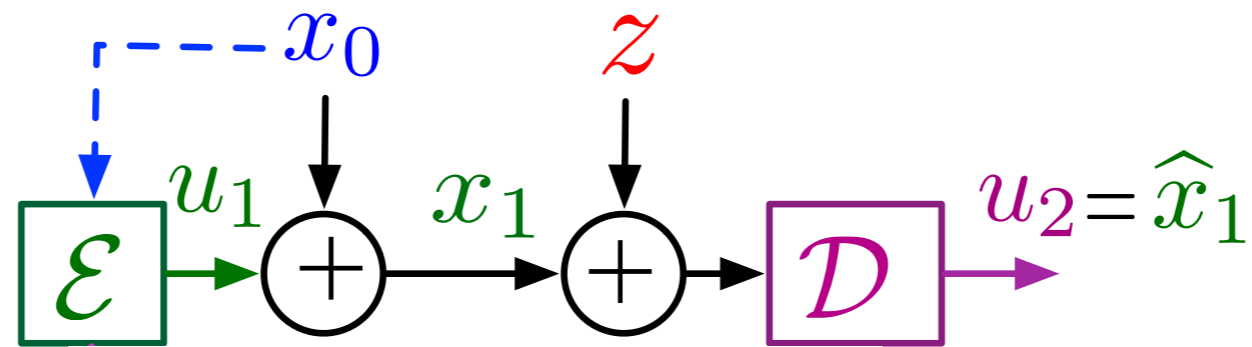

[Grover, Sahai '10]

More efficient: think “parallel channels”!

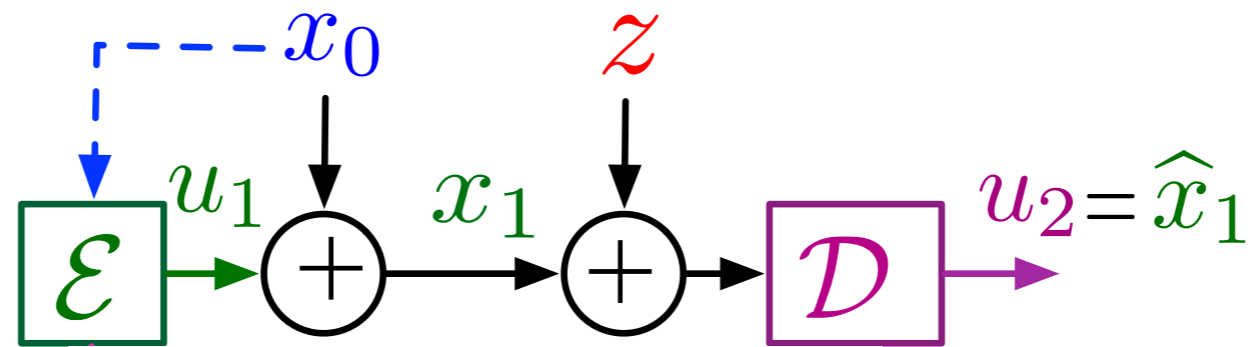

[Grover, Sahai '10]

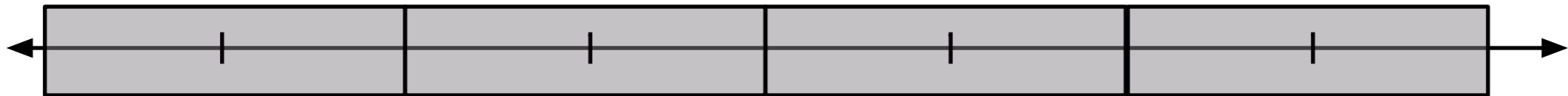

More efficient: think “parallel channels”!

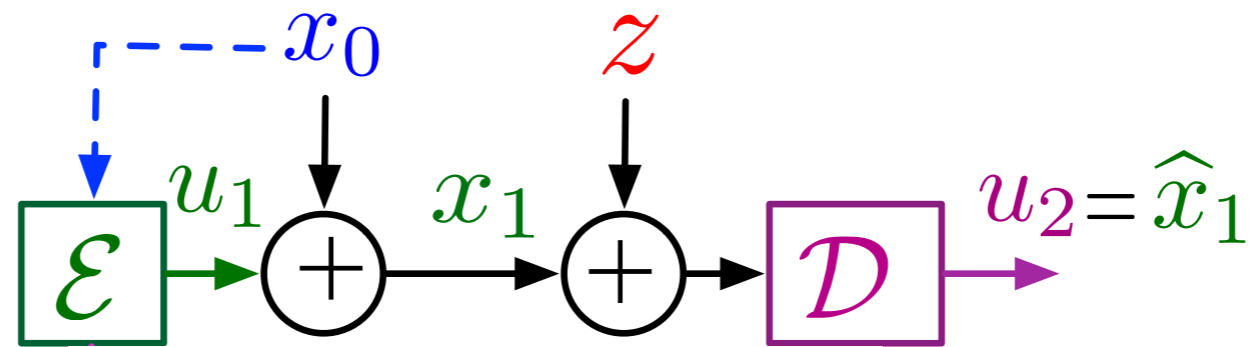

[Grover, Sahai '10]



More efficient: think “parallel channels”!

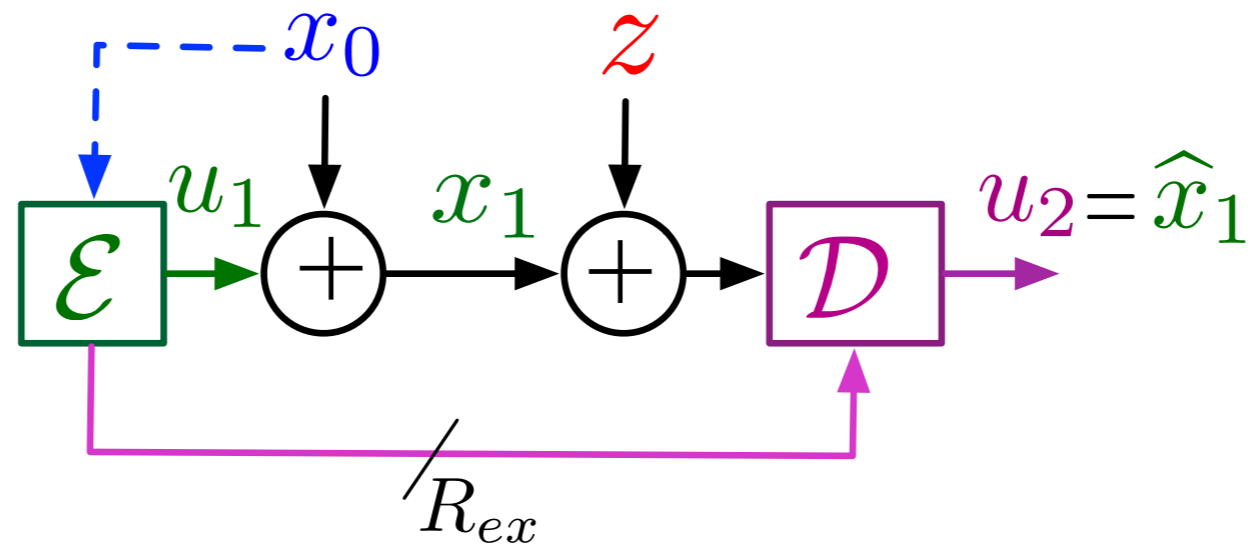

[Grover, Sahai '10]

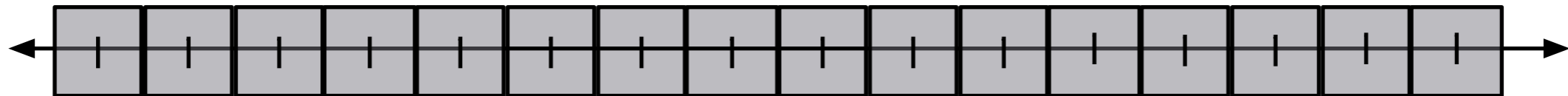

More efficient: think “parallel channels”!

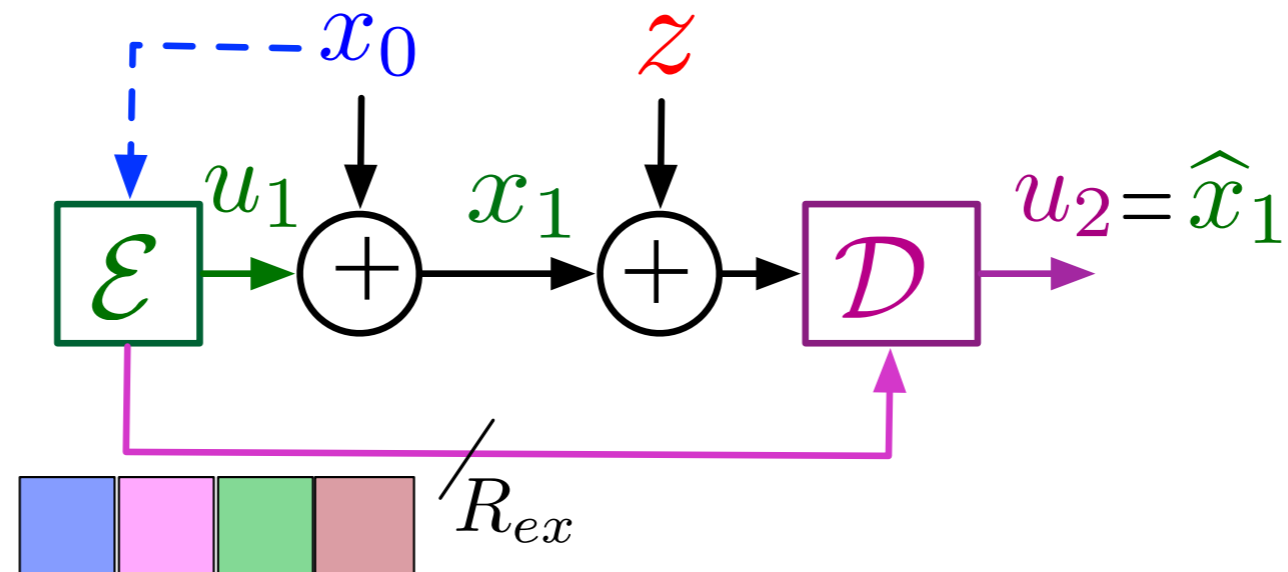

[Grover, Sahai '10]



More efficient: think “parallel channels”!

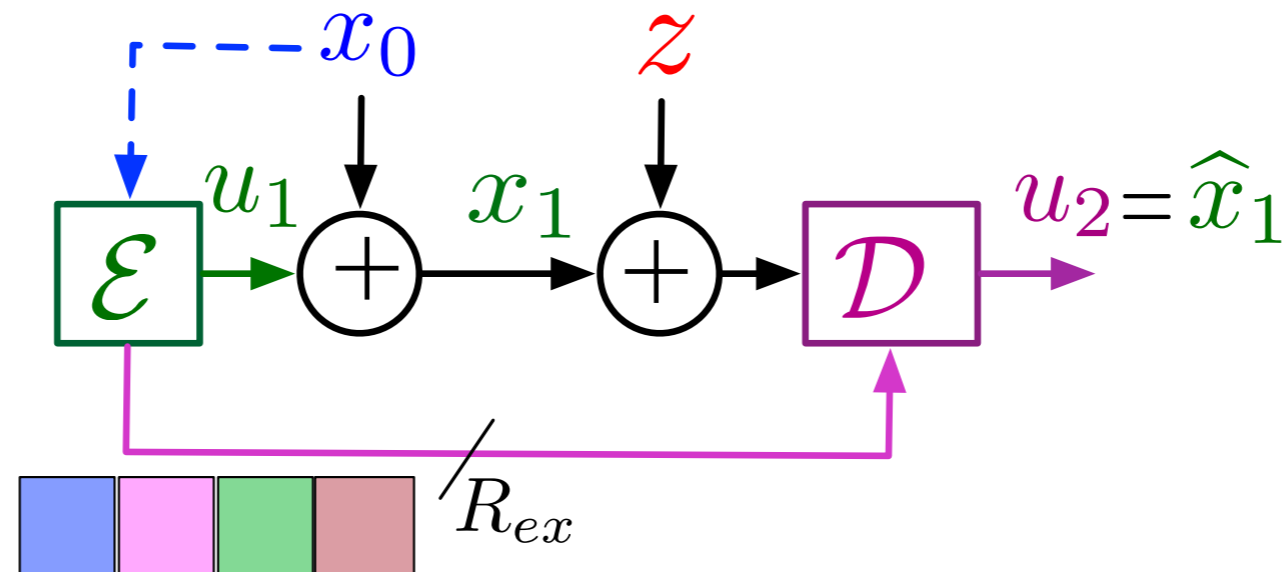

[Grover, Sahai '10]

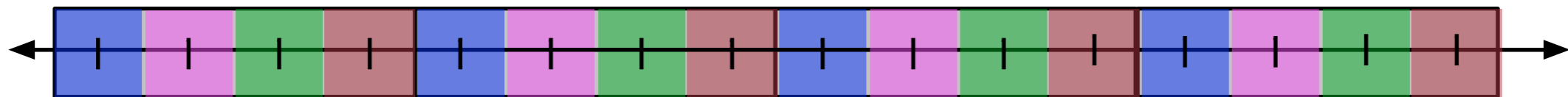

More efficient: think “parallel channels”!

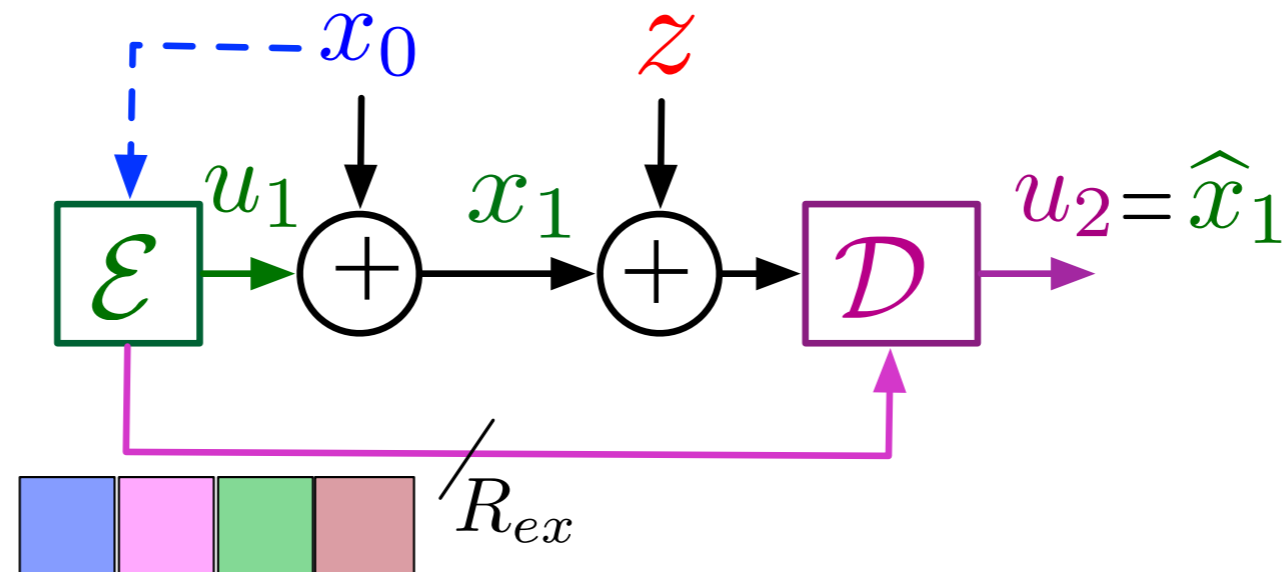

[Grover, Sahai '10]

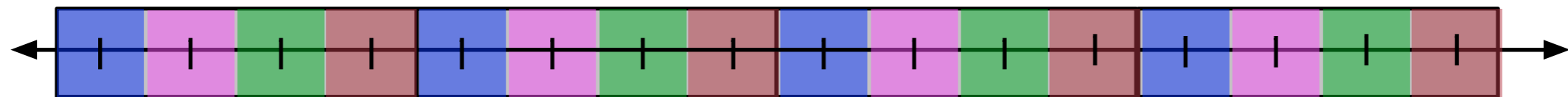

outperform Martins's strategies by an unbounded factor

More efficient: think “parallel channels”!

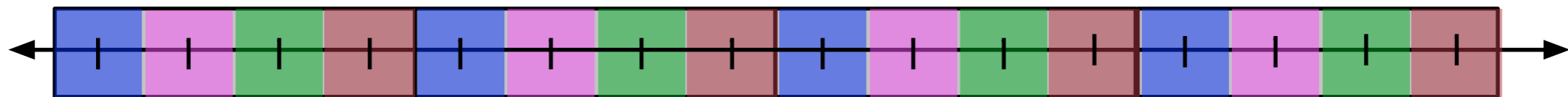
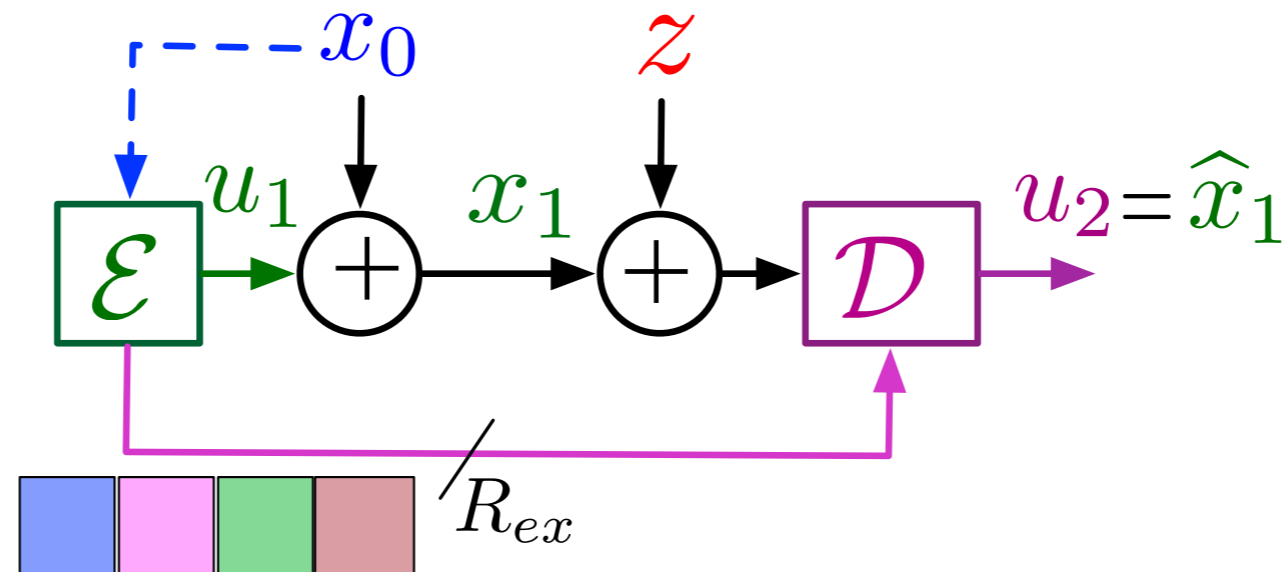

outperform Martins’s strategies by an unbounded factor

... are asymptotically-approximately-optimal

More efficient: think “parallel channels”!

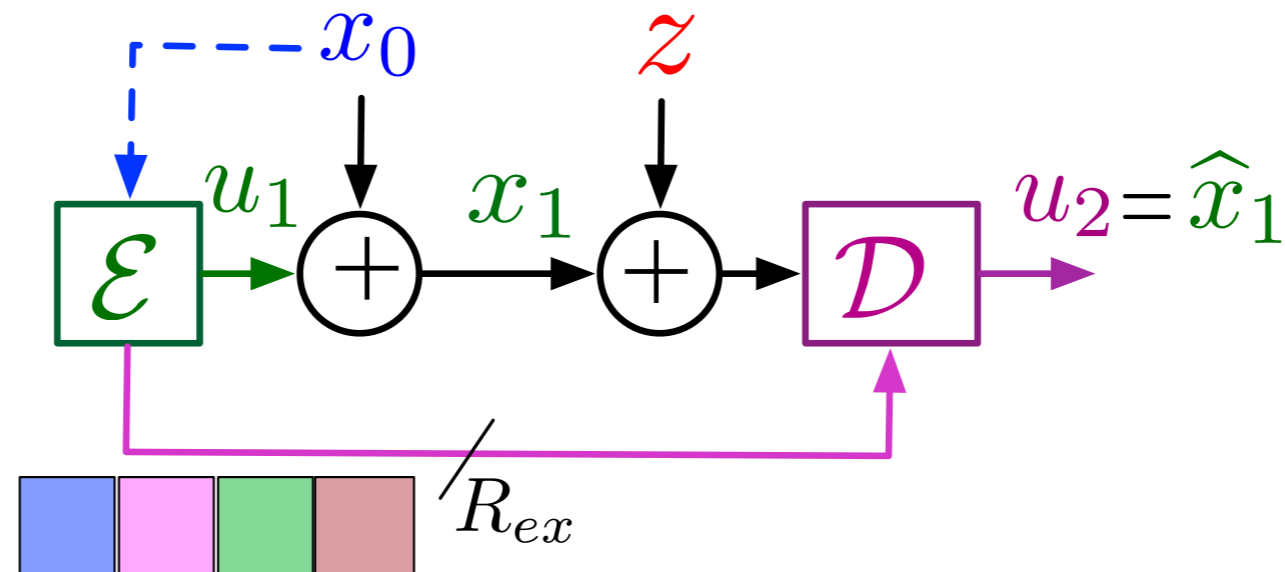

outperform Martins’s strategies by an unbounded factor

. . . are asymptotically-approximately-optimal

Moral:

More efficient: think “parallel channels”!

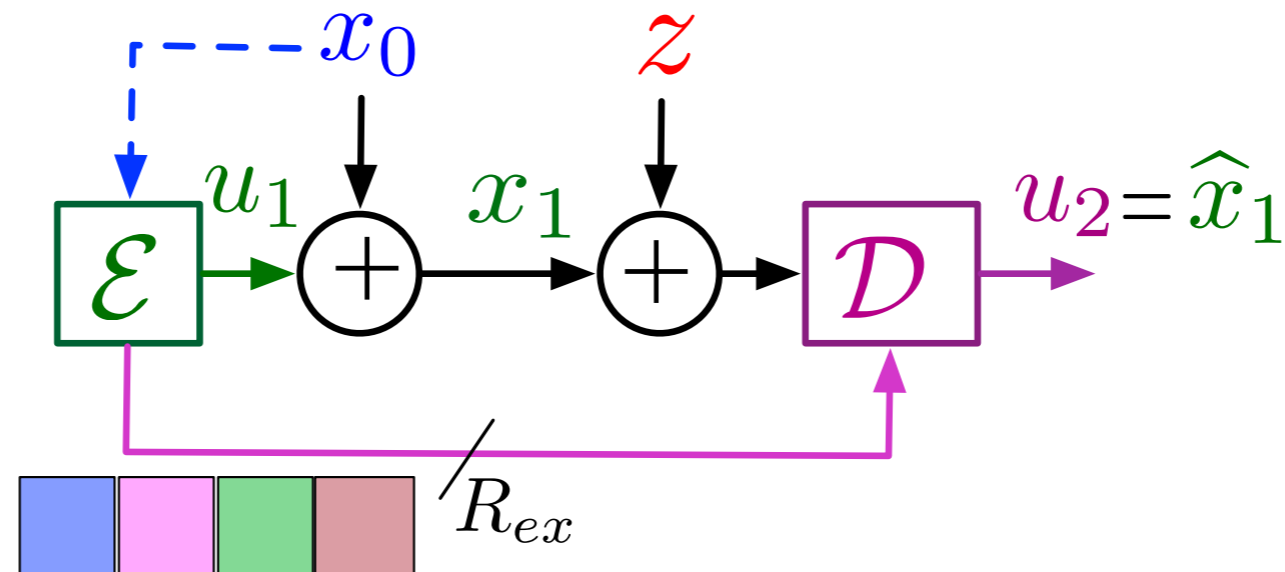

[Grover, Sahai '10]



outperform Martins’s strategies by an unbounded factor

. . . are asymptotically-approximately-optimal

Moral: refined information through channel

More efficient: think “parallel channels”!

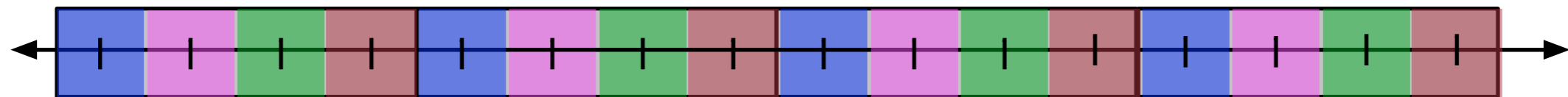
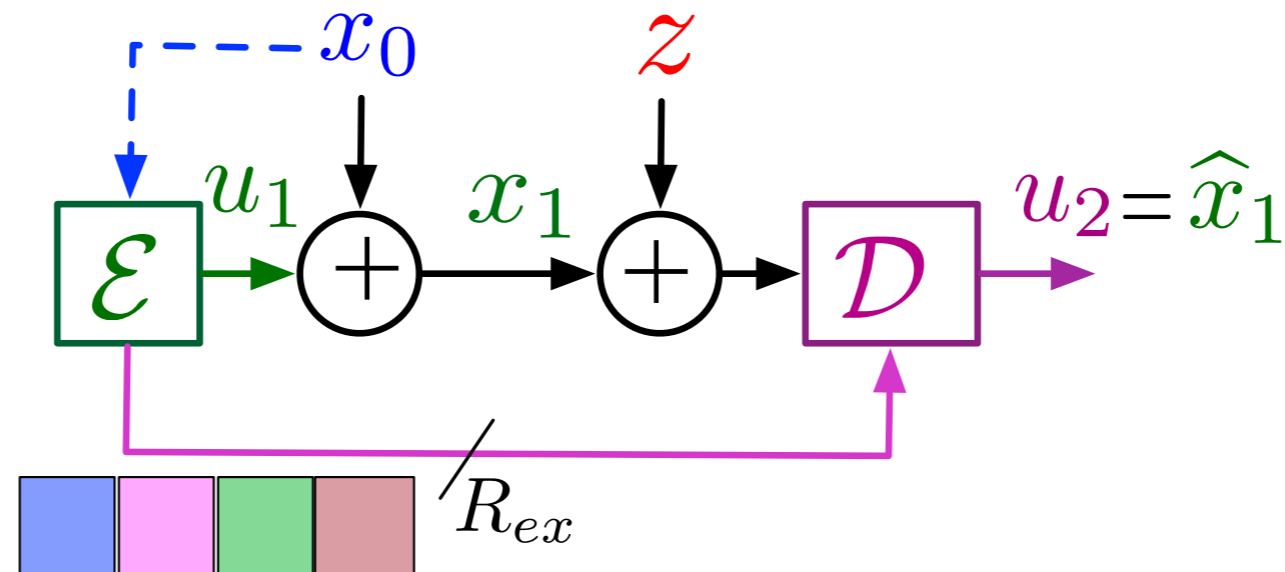

outperform Martins’s strategies by an unbounded factor

... are asymptotically-approximately-optimal

Moral: refined information through channel

signal most significant bits through plant

More efficient: think “parallel channels”!

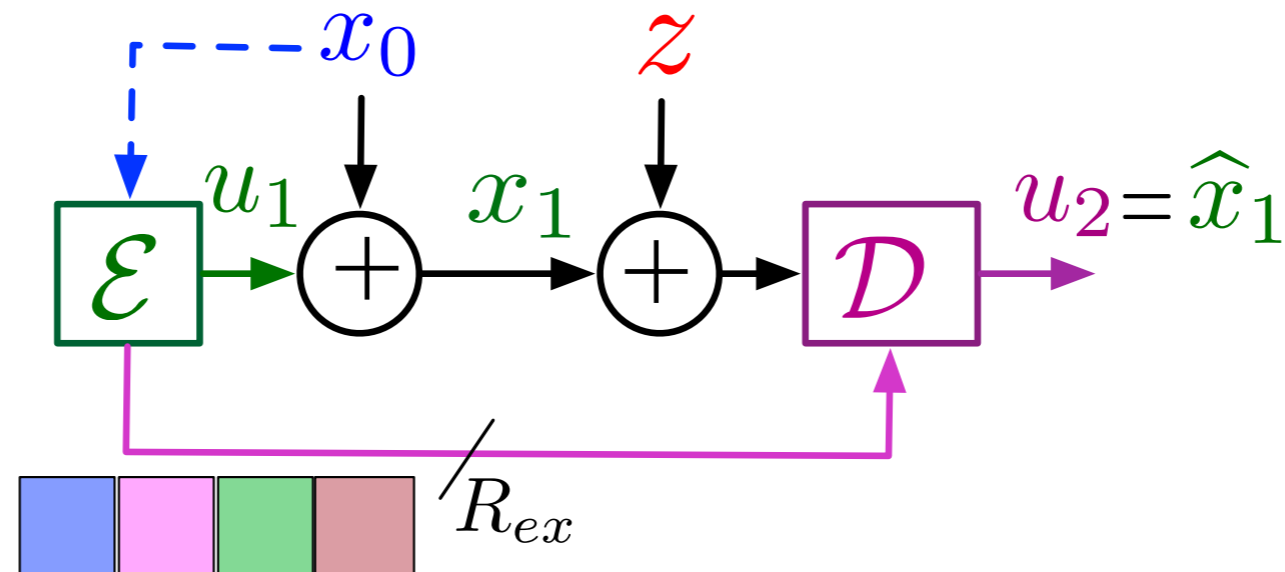

[Grover, Sahai '10]



outperform Martins’s strategies by an unbounded factor

... are asymptotically-approximately-optimal

Moral: refined information through channel

signal most significant bits through plant

Signal even when communication channel is present

Is the counterexample **relevant**? Part II

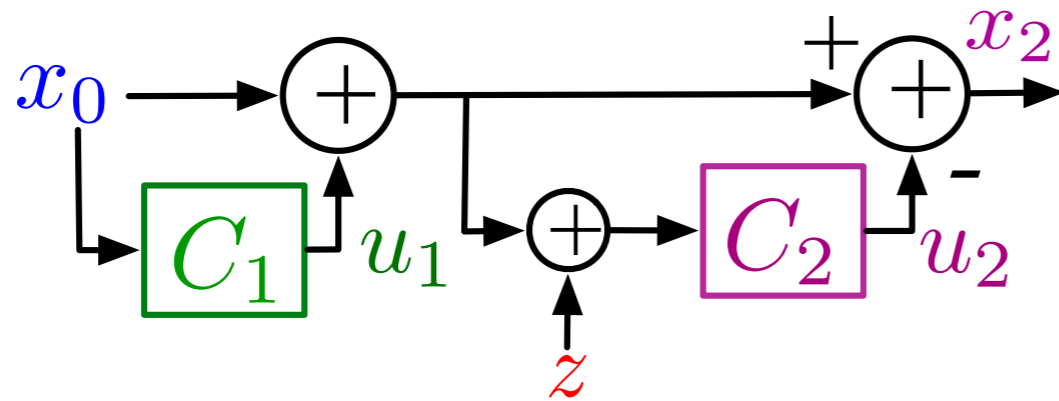

Is the counterexample **relevant**? Part II

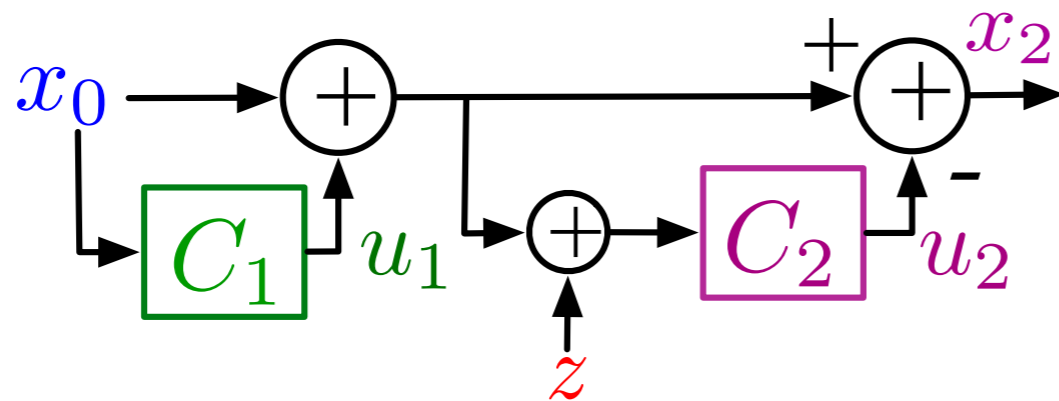

$$\min_{x_0, z} \max \frac{k^2 u_1^2 + x_2^2}{x_0^2 + z^2}$$

Is the counterexample **relevant**? Part II

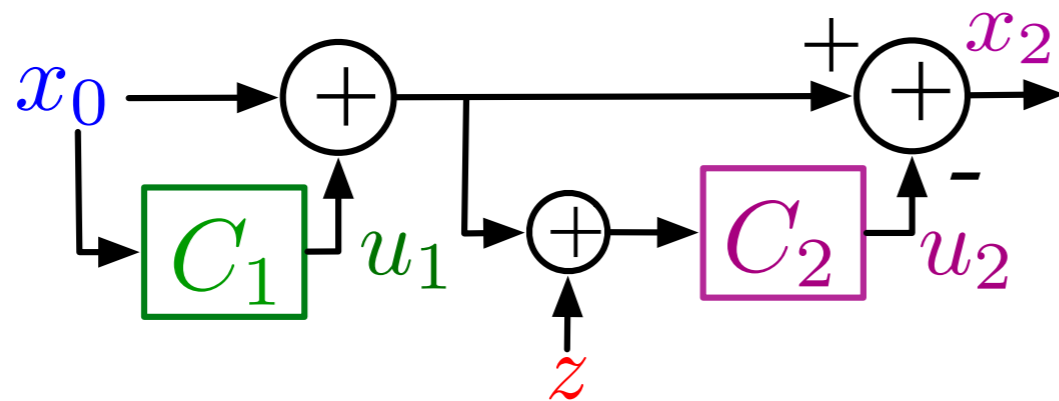

$$\min_{x_0, z} \max \frac{k^2 u_1^2 + x_2^2}{x_0^2 + z^2}$$

Induced norm: linear strategies optimal! [Rotkowitz '06]

Is the counterexample **relevant**? Part II

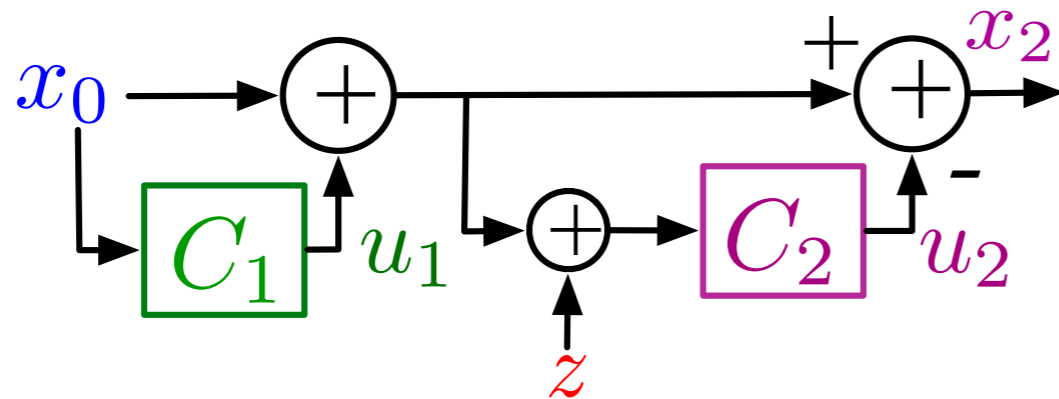

$$\min_{x_0, z} \max \frac{k^2 u_1^2 + x_2^2}{x_0^2 + z^2}$$

Induced norm: linear strategies optimal! [Rotkowitz '06]

Witsenhausen's LQG formulation:

Is the counterexample **relevant**? Part II

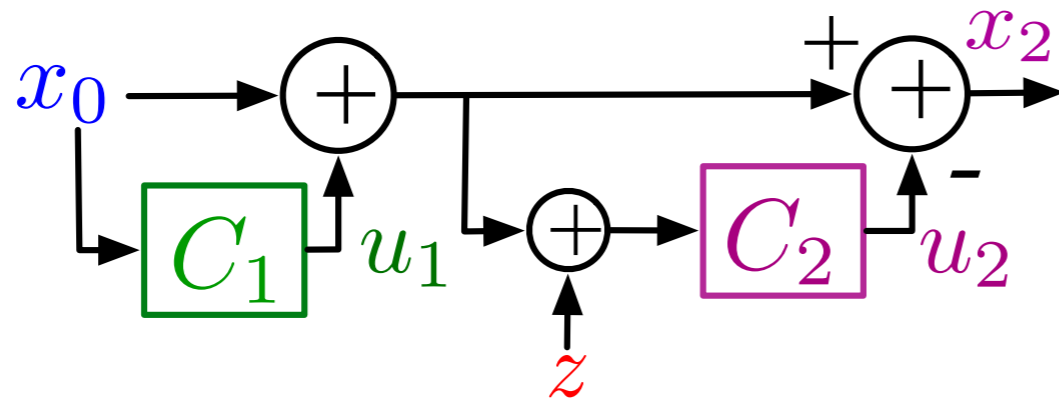

$$\min_{x_0, z} \max \frac{k^2 u_1^2 + x_2^2}{x_0^2 + z^2}$$

Induced norm: linear strategies optimal! [Rotkowitz '06]

Witsenhausen's LQG formulation: **more assumptions**

Is the counterexample **relevant**? Part II

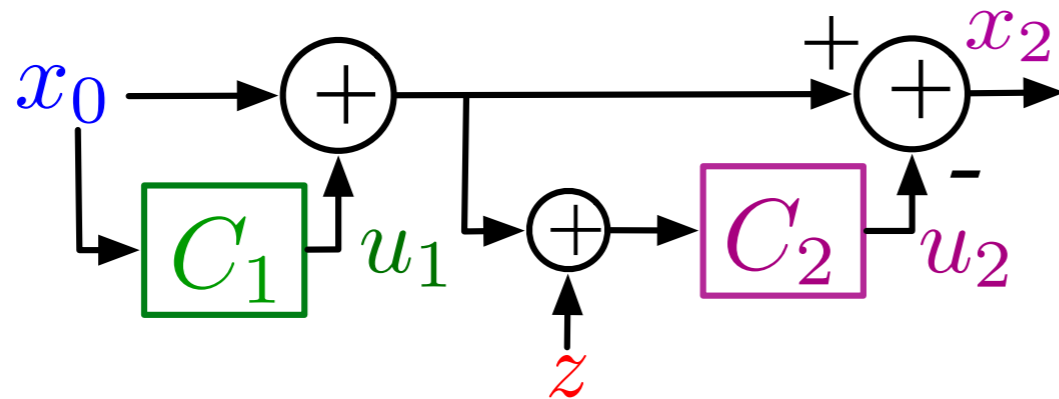

$$\min_{x_0, z} \max \frac{k^2 u_1^2 + x_2^2}{x_0^2 + z^2}$$

Induced norm: linear strategies optimal! [Rotkowitz '06]

Witsenhausen's LQG formulation: **more assumptions**
harder!

Is the counterexample **relevant**? Part II

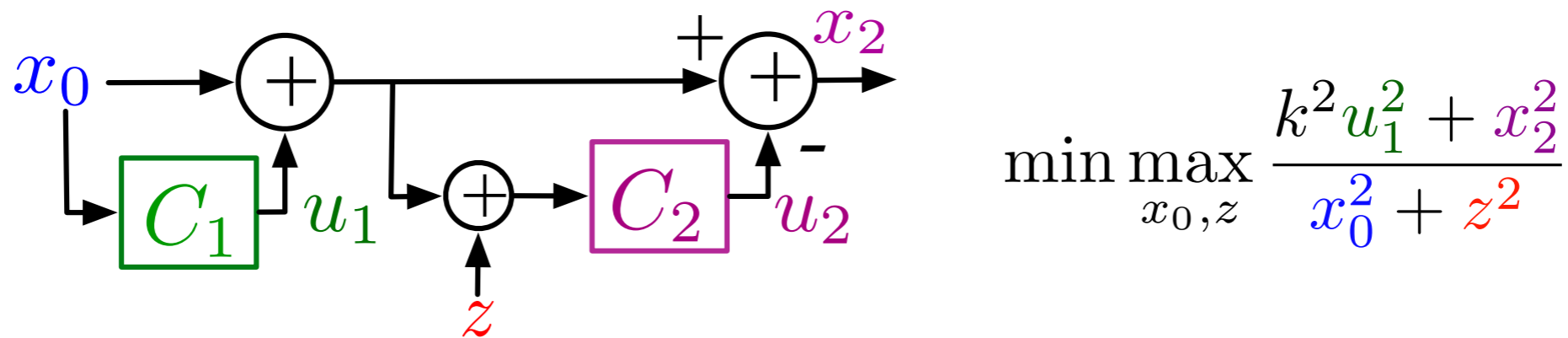

Induced norm: linear strategies optimal! [Rotkowitz '06]

Witsenhausen's LQG formulation: **more assumptions**
harder!

Q2. Why consider the quadratic norm?

[John Doyle, "Paths ahead", MIT, 2009]

Induced norm formulation too conservative?

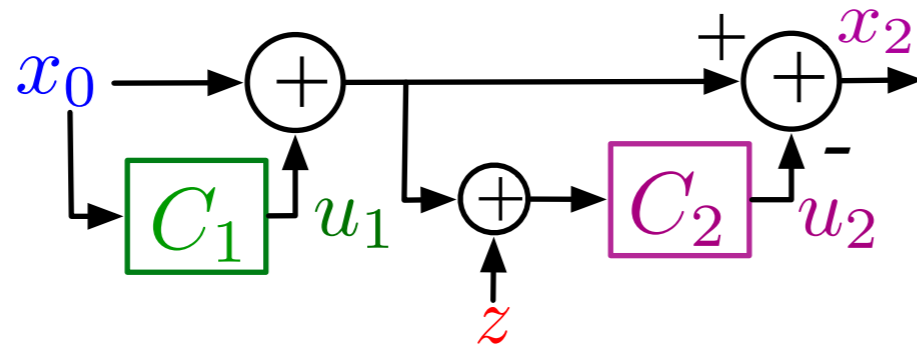

$$\min_{x_0, z} \max \frac{k^2 u_1^2 + x_2^2}{x_0^2 + z^2}$$

Induced norm formulation too conservative?

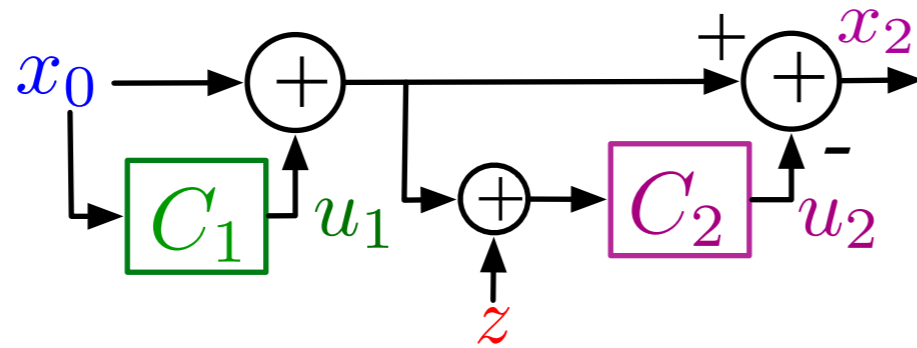

$$\min_{x_0, z} \max \frac{k^2 u_1^2 + x_2^2}{x_0^2 + z^2}$$

Makes no assumptions: noise **completely arbitrary, adversarial!**

Induced norm formulation too conservative?

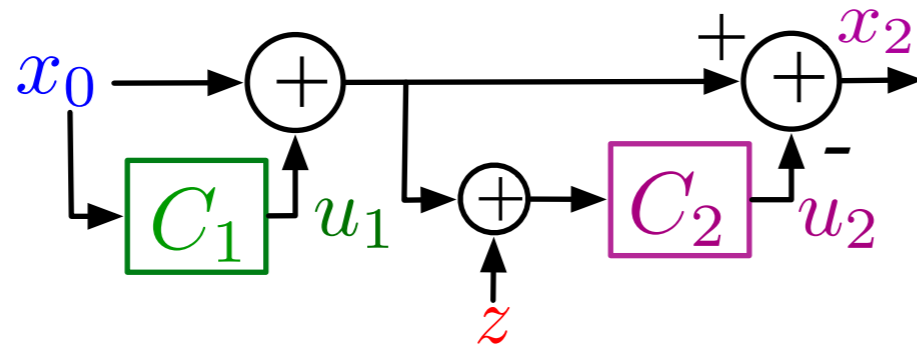

$$\min_{x_0, z} \max \frac{k^2 u_1^2 + x_2^2}{x_0^2 + z^2}$$

Makes no assumptions: noise **completely arbitrary, adversarial!**

Usually we know *something* about the noise, e.g. “typical” values, or bounds

Induced norm formulation too conservative?

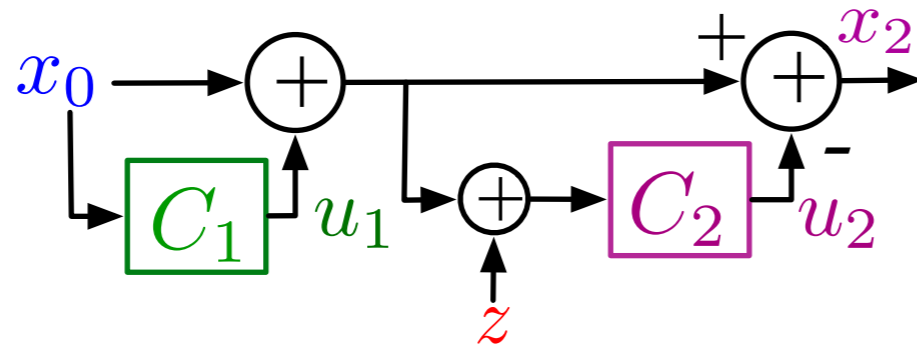

$$\min_{x_0, z} \max \frac{k^2 u_1^2 + x_2^2}{x_0^2 + z^2}$$

Makes no assumptions: noise **completely arbitrary, adversarial!**

Usually we know *something* about the noise, e.g. “typical” values, or bounds

$$\text{say } z \in (-a, a)$$

Induced norm formulation too conservative?

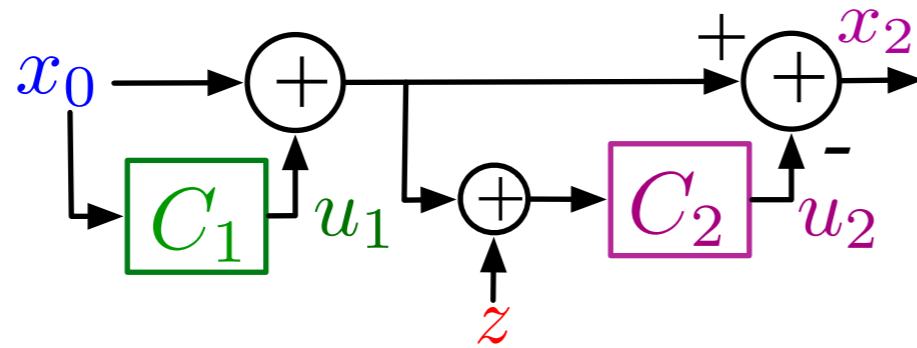

$$\min_{x_0, z} \max \frac{k^2 u_1^2 + x_2^2}{x_0^2 + z^2}$$

Makes no assumptions: noise **completely arbitrary, adversarial!**

Usually we know *something* about the noise, e.g. “typical” values, or bounds

$$\text{say } z \in (-a, a)$$

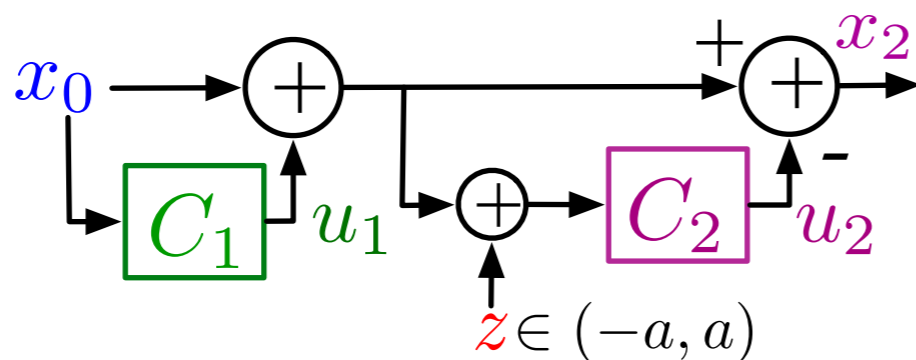

Induced norm formulation too conservative?

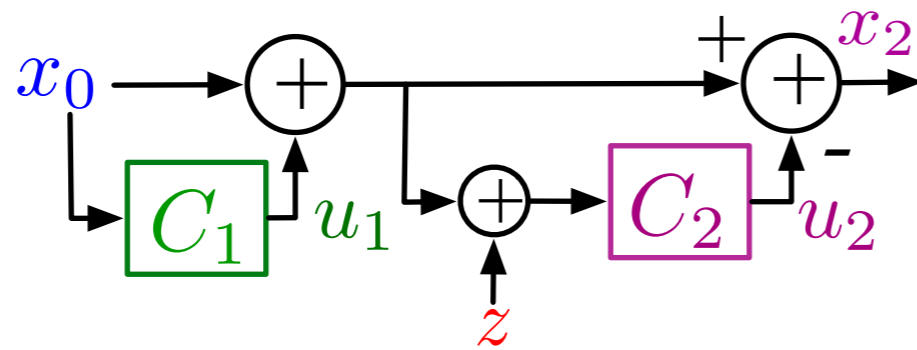

$$\min_{x_0, z} \max \frac{k^2 u_1^2 + x_2^2}{x_0^2 + z^2}$$

Makes no assumptions: noise **completely arbitrary, adversarial!**

Usually we know *something* about the noise, e.g. “typical” values, or bounds
say $z \in (-a, a)$

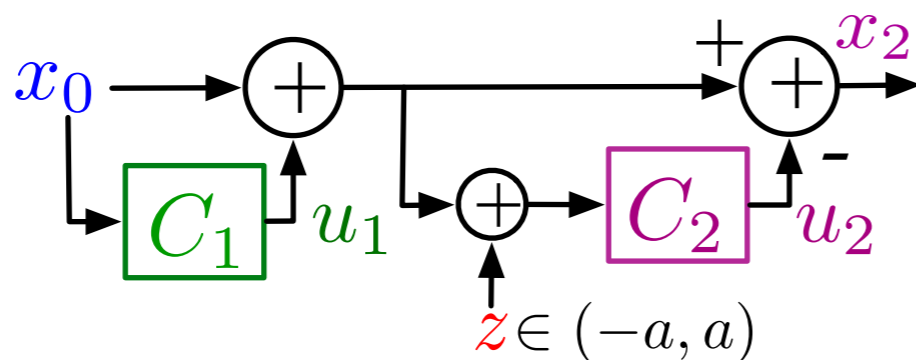

A quadratic cost

$$\min_{x_0, z \in (-a, a)} \max k^2 u_1^2 + x_2^2$$

Induced norm formulation too conservative?

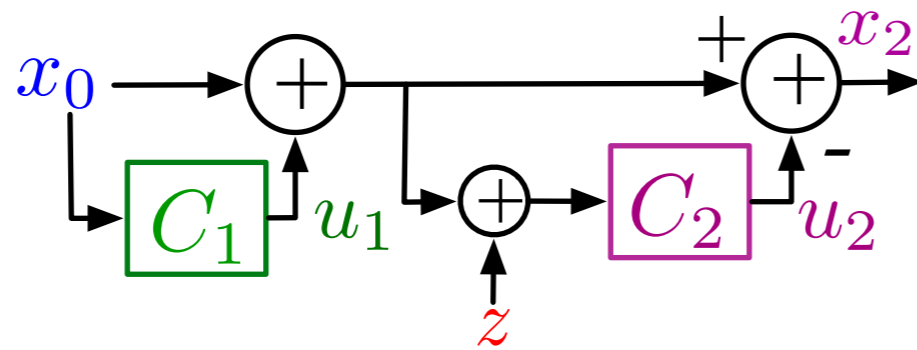

$$\min_{x_0, z} \max \frac{k^2 u_1^2 + x_2^2}{x_0^2 + z^2}$$

Makes no assumptions: noise **completely arbitrary, adversarial!**

Usually we know *something* about the noise, e.g. “typical” values, or bounds
say $z \in (-a, a)$

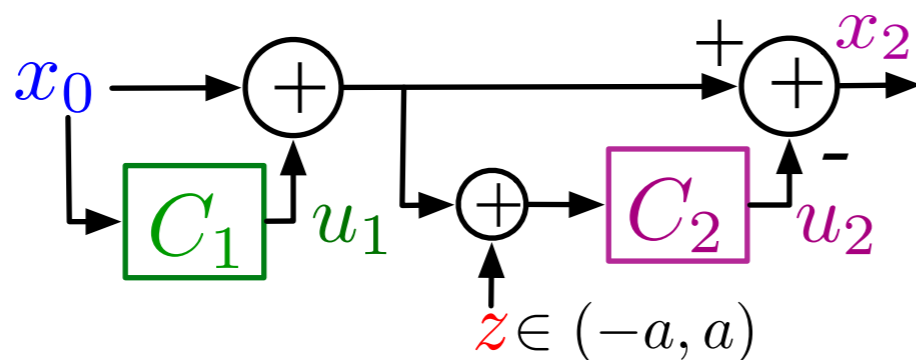

A quadratic cost

$$\min_{x_0, z \in (-a, a)} \max k^2 u_1^2 + x_2^2$$

Quantization (**signaling**) :

Induced norm formulation too conservative?

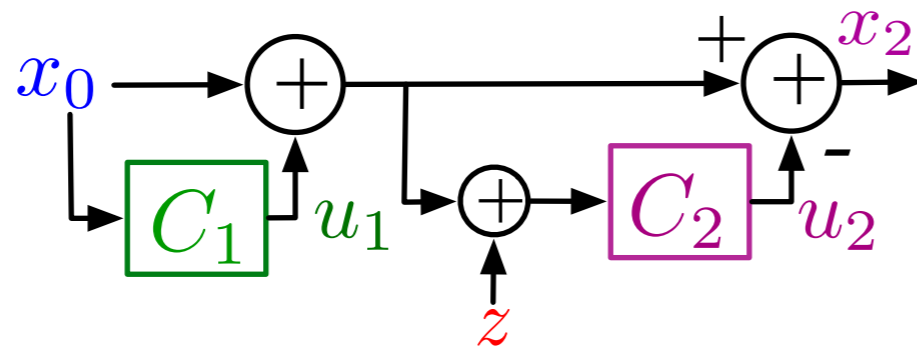

$$\min_{x_0, z} \max \frac{k^2 u_1^2 + x_2^2}{x_0^2 + z^2}$$

Makes no assumptions: noise **completely arbitrary, adversarial!**

Usually we know *something* about the noise, e.g. “typical” values, or bounds
say $z \in (-a, a)$

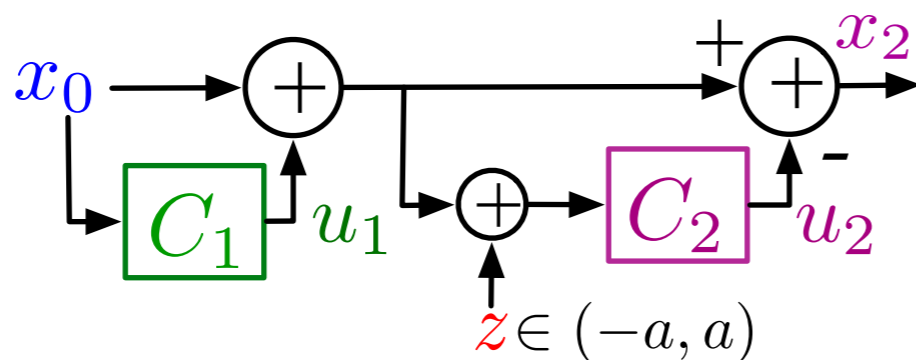

A quadratic cost

$$\min_{x_0, z \in (-a, a)} \max k^2 u_1^2 + x_2^2$$

Quantization (**signaling**): can outperform linear by an **unbounded** factor

Induced norm formulation too conservative?

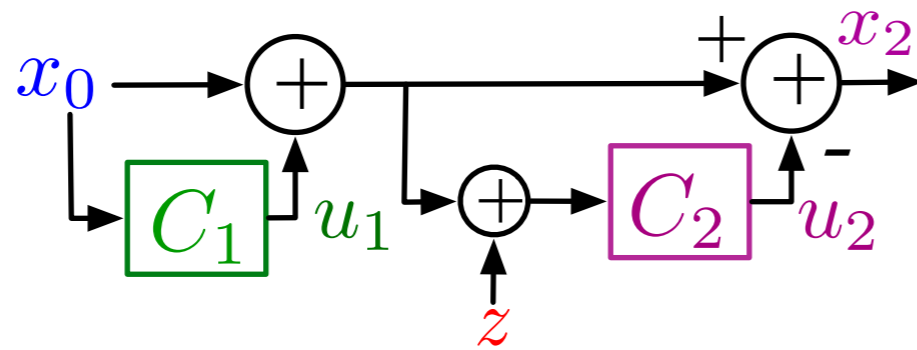

$$\min_{x_0, z} \max \frac{k^2 u_1^2 + x_2^2}{x_0^2 + z^2}$$

Makes no assumptions: noise **completely arbitrary, adversarial!**

Usually we know *something* about the noise, e.g. “typical” values, or bounds
say $z \in (-a, a)$

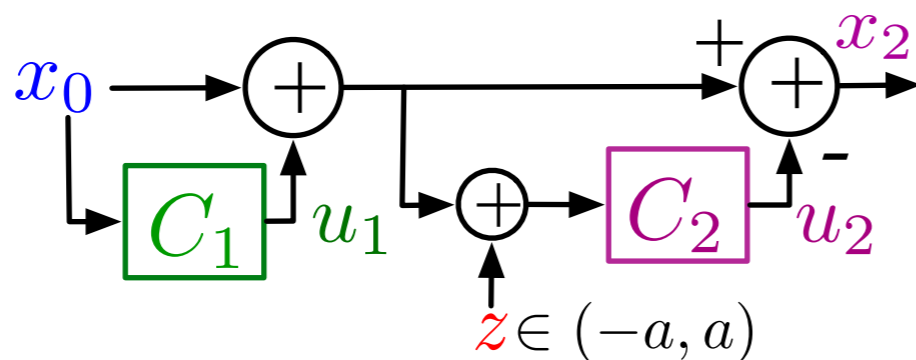

A quadratic cost

$$\min_{x_0, z \in (-a, a)} \max k^2 u_1^2 + x_2^2$$

Quantization (**signaling**): can outperform linear by an **unbounded** factor
is **approximately optimal!**

Which is a “right” norm?

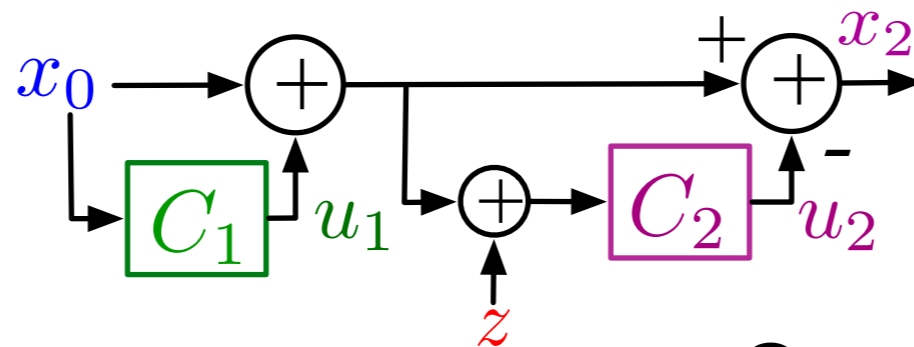

Induced norm

$$\min_{x_0, z} \max \frac{k^2 u_1^2 + x_2^2}{x_0^2 + z^2}$$

Quadratic norm

$$\min_{x_0, z \in (-a, a)} \max k^2 u_1^2 + x_2^2$$

Which is a “right” norm?

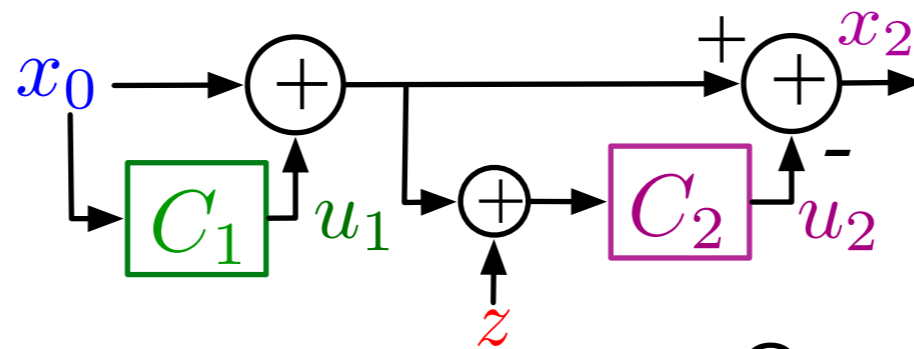

Induced norm

$$\min_{x_0, z} \max \frac{k^2 u_1^2 + x_2^2}{x_0^2 + z^2}$$

Quadratic norm

$$\min_{x_0, z \in (-a, a)} \max k^2 u_1^2 + x_2^2$$

Induced norm: cost normalized by **size of state and noise**.

Which is a “right” norm?

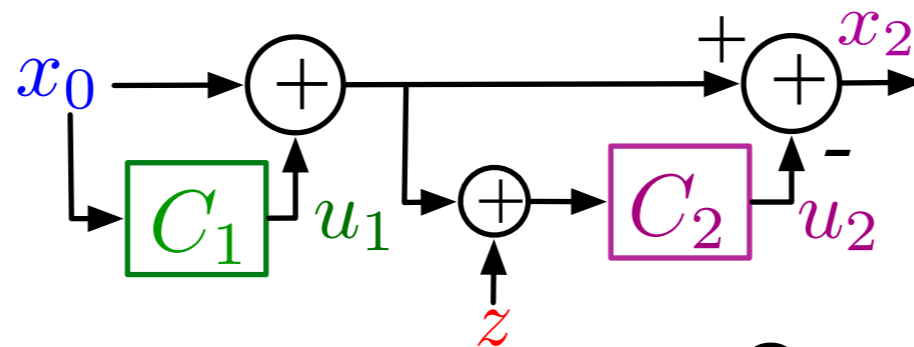

Induced norm

$$\min_{x_0, z} \max \frac{k^2 u_1^2 + x_2^2}{x_0^2 + z^2}$$

Quadratic norm

$$\min_{x_0, z \in (-a, a)} \max k^2 u_1^2 + x_2^2$$

Induced norm: cost normalized by **size of state and noise**.

In many practical cases, small perturbations and small noises **do cost less!**

Which is a “right” norm?

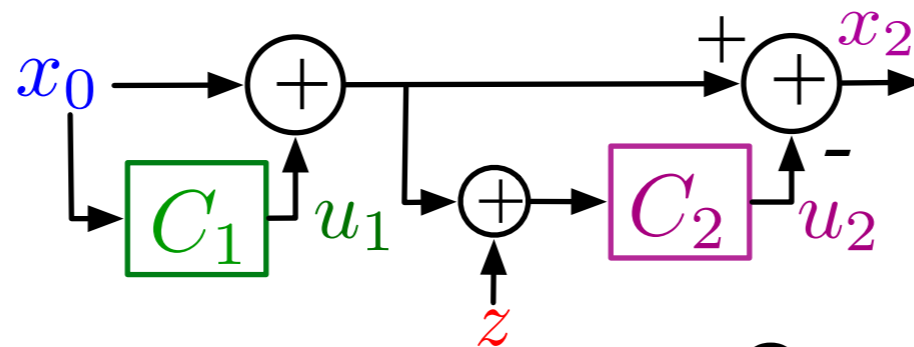

Induced norm

$$\min_{x_0, z} \max \frac{k^2 u_1^2 + x_2^2}{x_0^2 + z^2}$$

Quadratic norm

$$\min_{x_0, z \in (-a, a)} \max k^2 u_1^2 + x_2^2$$

Induced norm: cost normalized by **size of state and noise**.

In many practical cases, small perturbations and small noises **do cost less!**

Quadratic norm captures **how much large perturbations/noises hurt**

Which is a “right” norm?

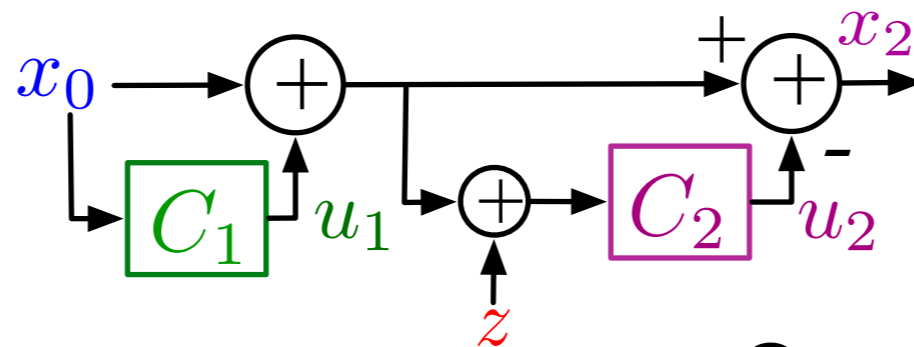

Induced norm

$$\min_{x_0, z} \max \frac{k^2 u_1^2 + x_2^2}{x_0^2 + z^2}$$

Quadratic norm

$$\min_{x_0, z \in (-a, a)} \max k^2 u_1^2 + x_2^2$$

Induced norm: cost normalized by **size of state and noise**.

In many practical cases, small perturbations and small noises **do cost less!**

Quadratic norm captures **how much large perturbations/noises hurt**

Moral: **signal** even in **adversarial** situations

What problems could we address now?

Goal: control a system using decentralized connected controllers

What problems could we address now?

Goal: control a system using decentralized connected controllers

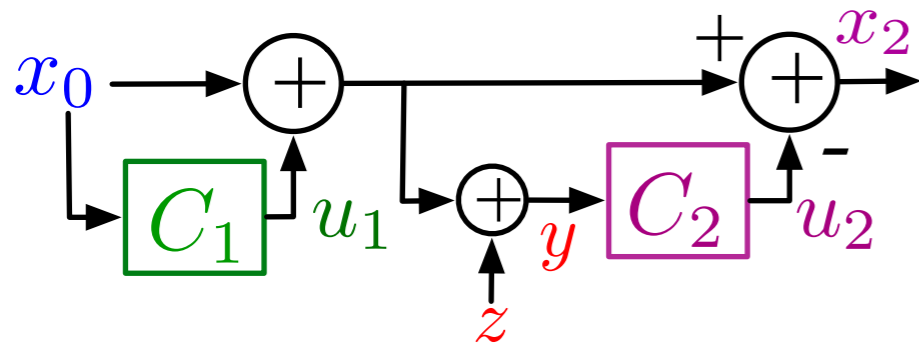

Witsenhausen's counterexample

What problems could we address now?

Goal: control a system using decentralized connected controllers

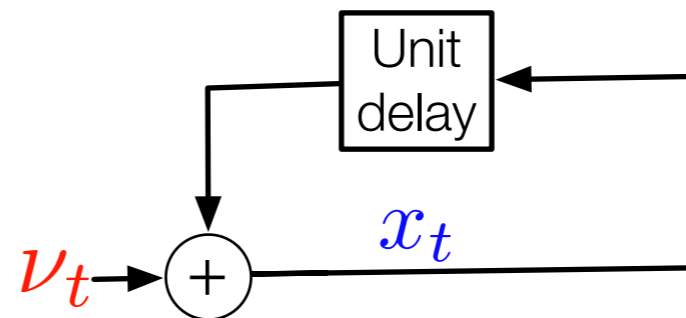
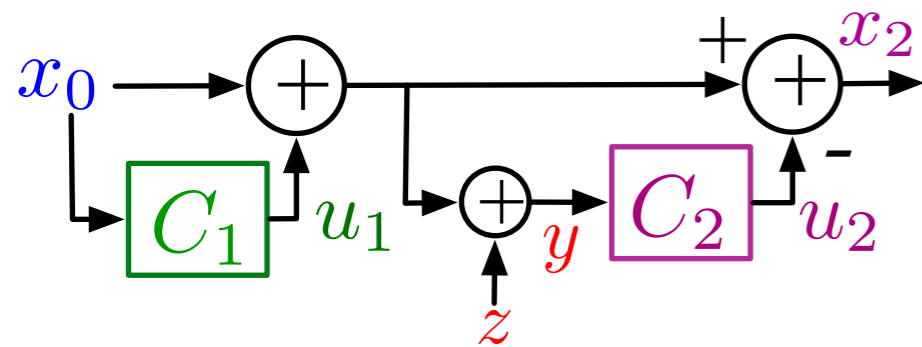

Witsenhausen's counterexample

communicating an evolving source

- [Wong, Brockett '90]
- [Borkar, Mitter '95]
- [Tatikonda, Mitter '01]
- [Sahai, Mitter '02]
- [Martins, Dahleh '08]
- [Yüksel, Başar '11]

What problems could we address now?

Goal: control a system using decentralized connected controllers

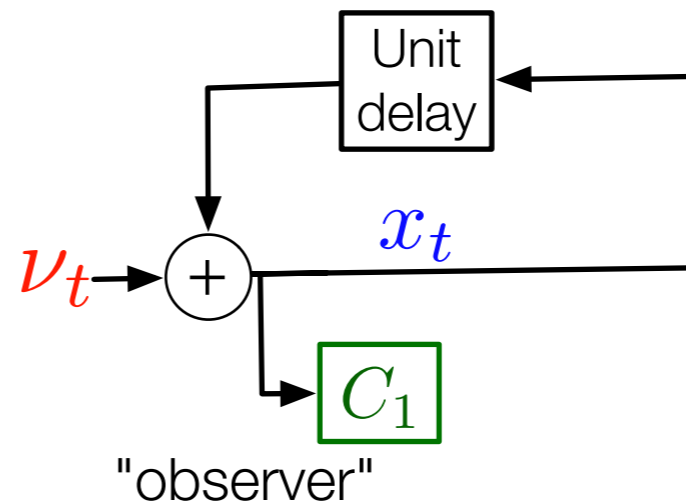
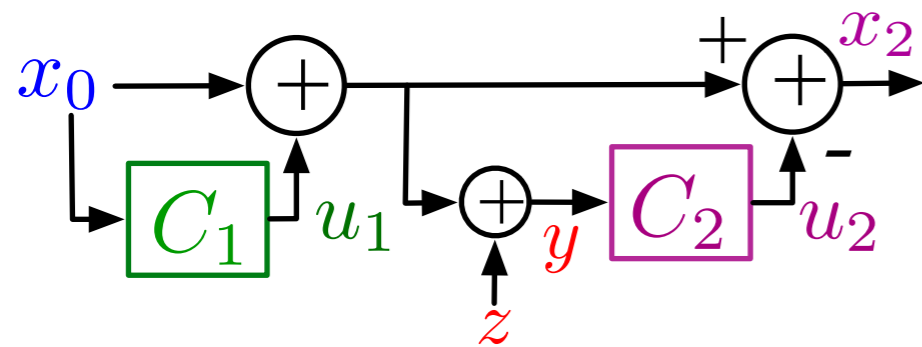

Witsenhausen's counterexample

communicating an evolving source

- [Wong, Brockett '90]
- [Borkar, Mitter '95]
- [Tatikonda, Mitter '01]
- [Sahai, Mitter '02]
- [Martins, Dahleh '08]
- [Yüksel, Başar '11]

What problems could we address now?

Goal: control a system using decentralized connected controllers

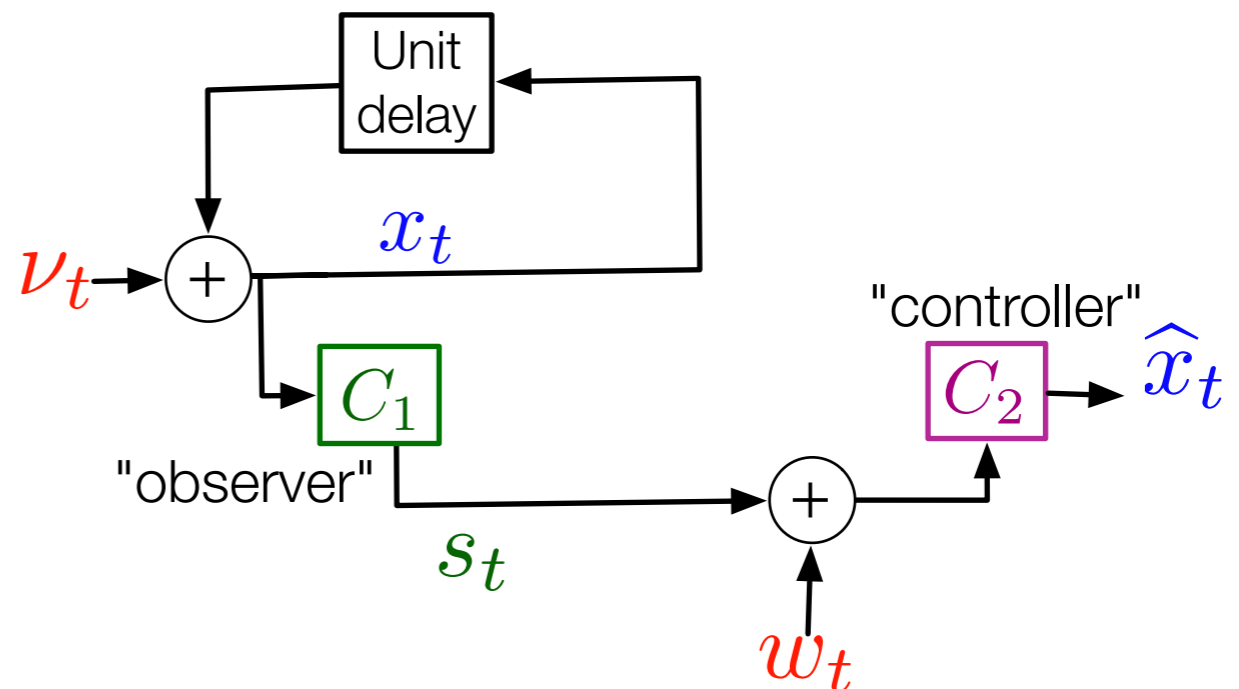
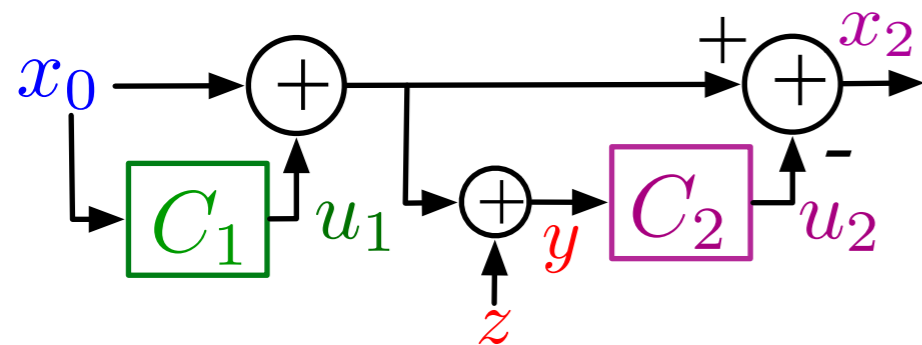

Witsenhausen's counterexample

communicating an evolving source

- [Wong, Brockett '90]
- [Borkar, Mitter '95]
- [Tatikonda, Mitter '01]
- [Sahai, Mitter '02]
- [Martins, Dahleh '08]
- [Yüksel, Başar '11]

What problems could we address now?

Goal: control a system using decentralized connected controllers

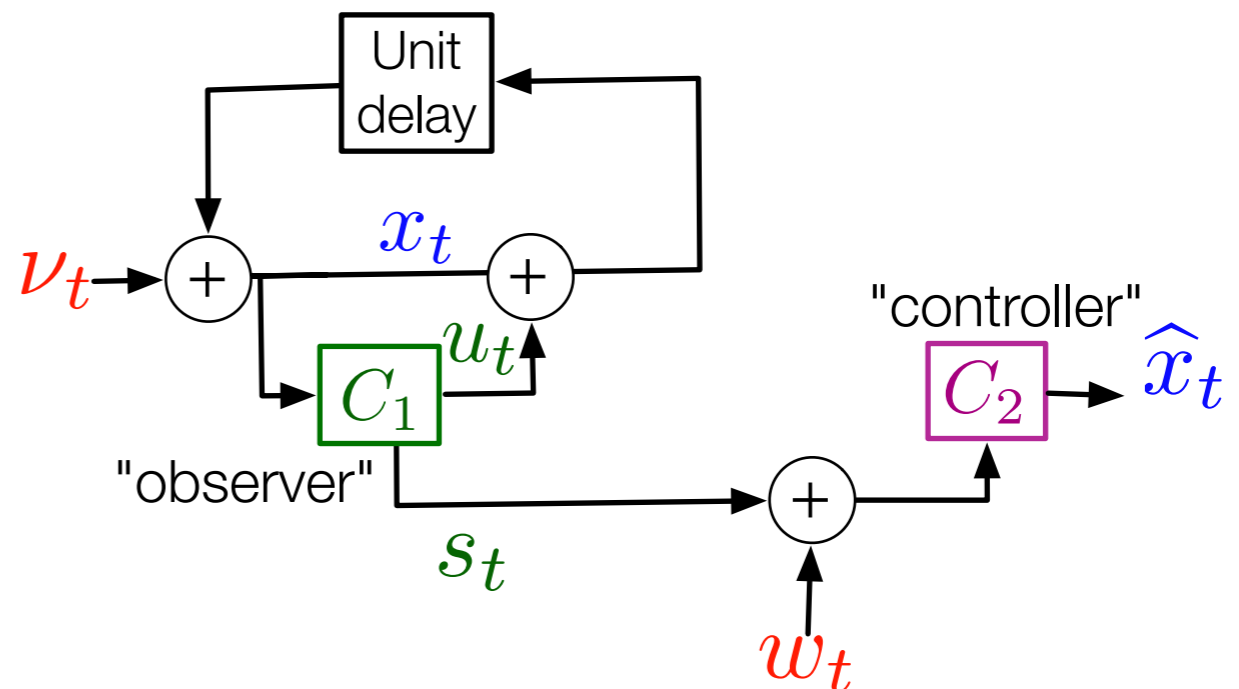
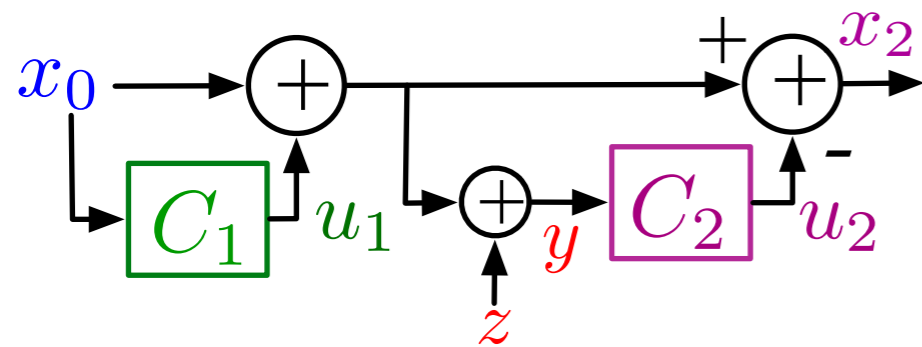

Witsenhausen's counterexample

communicating an evolving source

- [Wong, Brockett '90]
- [Borkar, Mitter '95]
- [Tatikonda, Mitter '01]
- [Sahai, Mitter '02]
- [Martins, Dahleh '08]
- [Yüksel, Başar '11]

What problems could we address now?

Goal: control a system using decentralized connected controllers

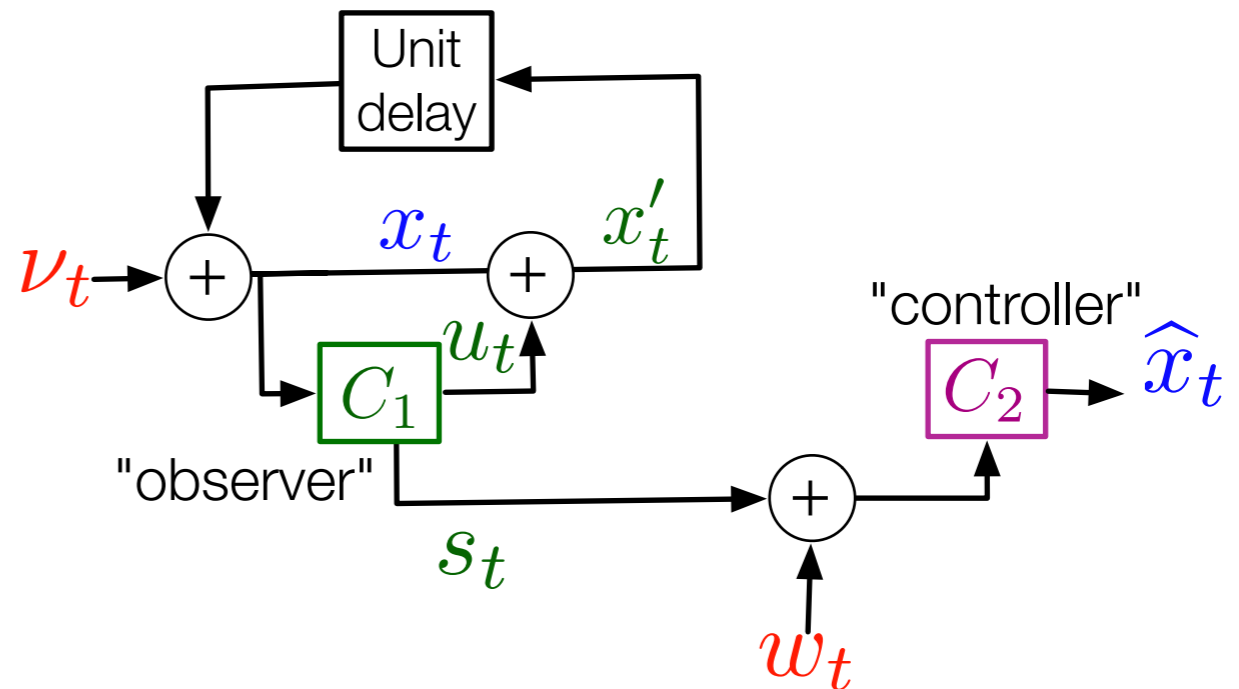
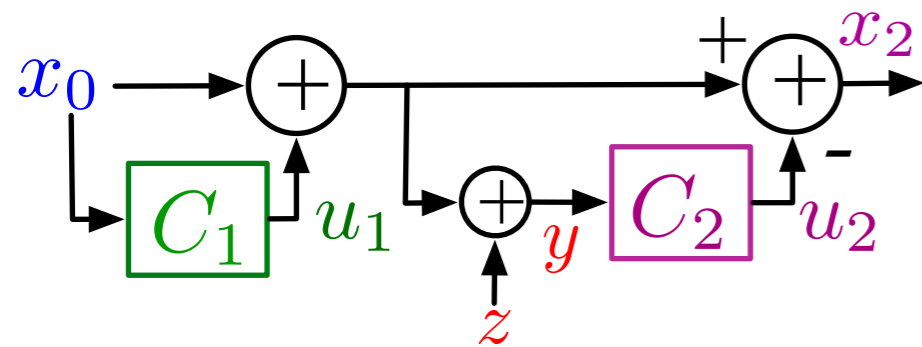

Witsenhausen's counterexample

communicating an evolving source

- [Wong, Brockett '90]
- [Borkar, Mitter '95]
- [Tatikonda, Mitter '01]
- [Sahai, Mitter '02]
- [Martins, Dahleh '08]
- [Yüksel, Başar '11]

What problems could we address now?

Goal: control a system using decentralized connected controllers

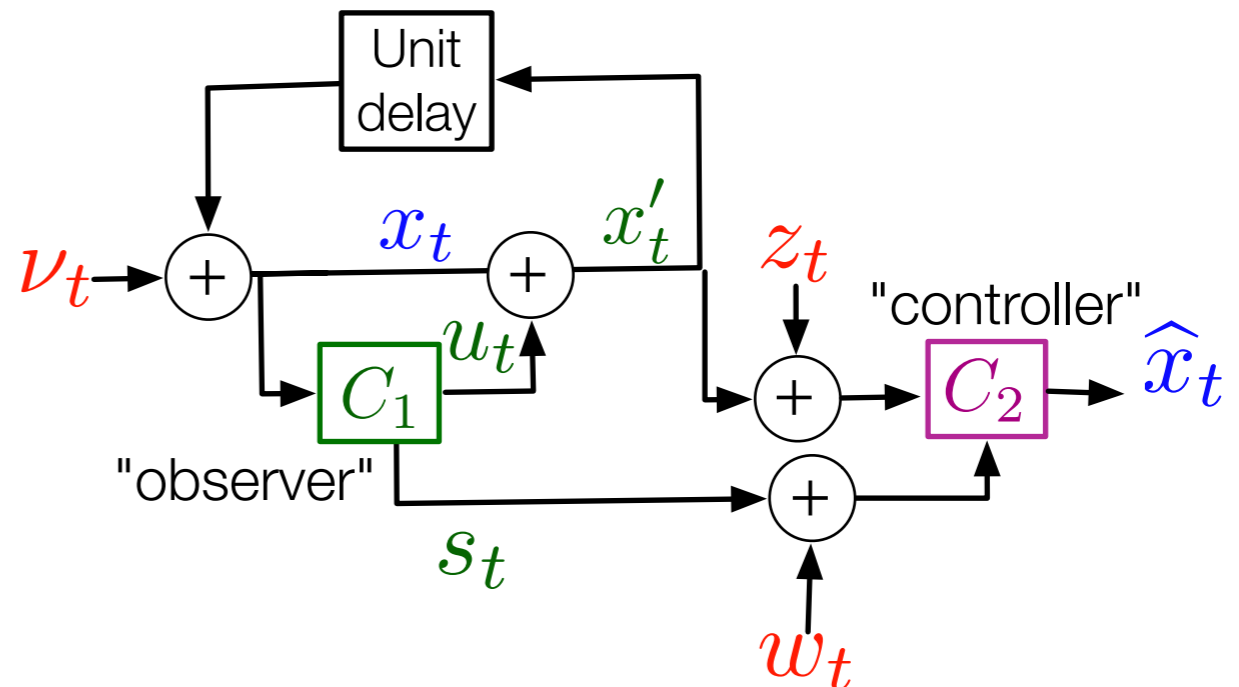
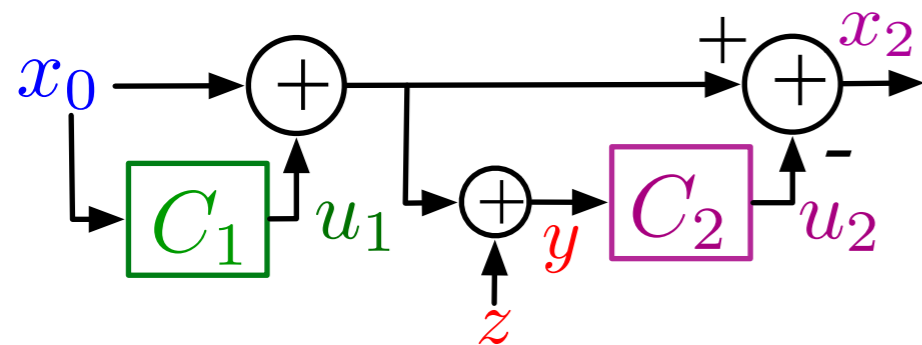

Witsenhausen's counterexample

communicating an evolving source

- [Wong, Brockett '90]
- [Borkar, Mitter '95]
- [Tatikonda, Mitter '01]
- [Sahai, Mitter '02]
- [Martins, Dahleh '08]
- [Yüksel, Başar '11]

What problems could we address now?

Goal: control a system using decentralized connected controllers

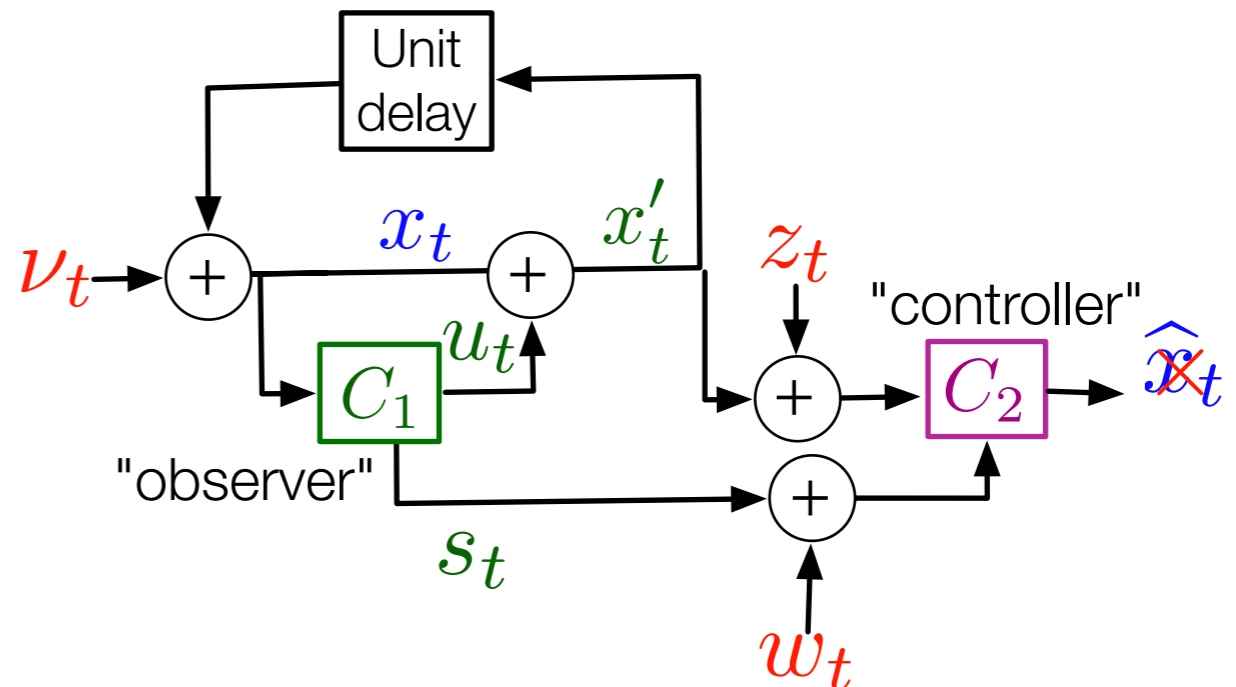
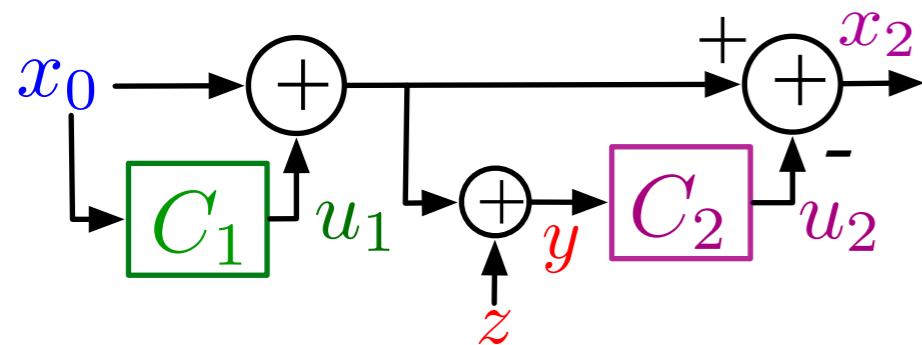

Witsenhausen's counterexample

communicating an evolving source

- [Wong, Brockett '90]
- [Borkar, Mitter '95]
- [Tatikonda, Mitter '01]
- [Sahai, Mitter '02]
- [Martins, Dahleh '08]
- [Yüksel, Başar '11]

What problems could we address now?

Goal: control a system using decentralized connected controllers

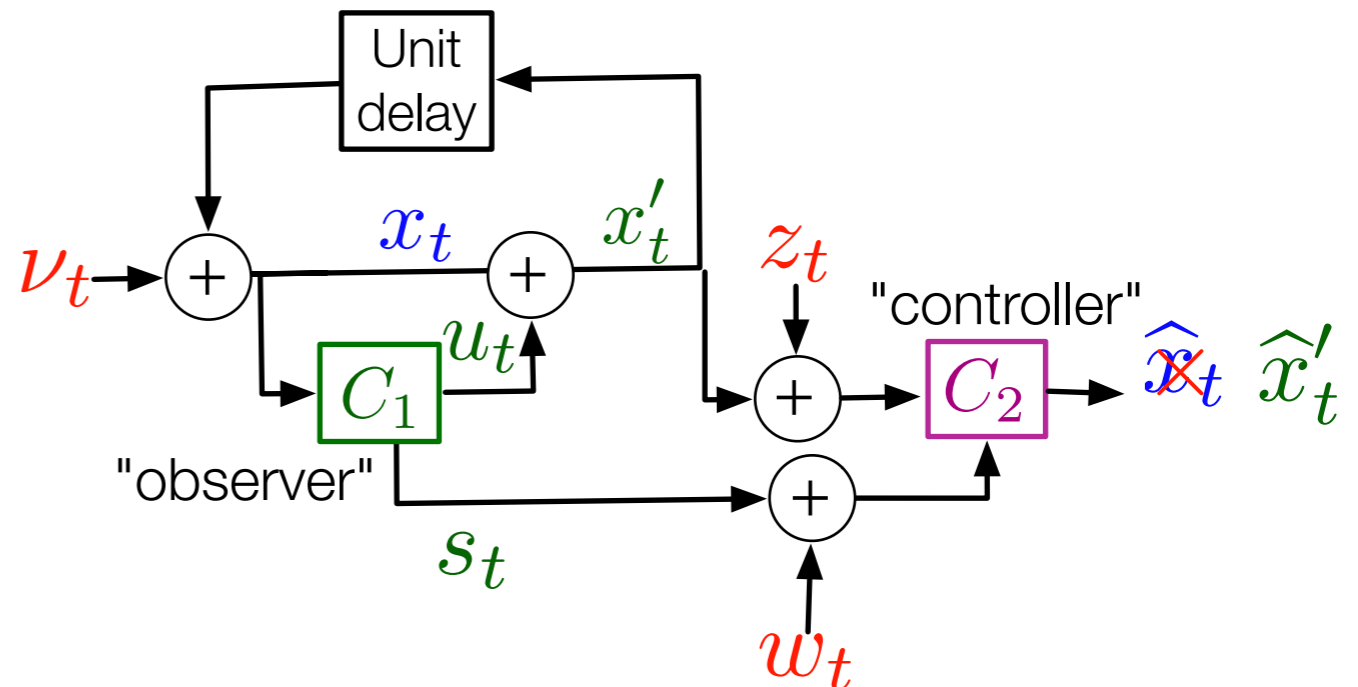
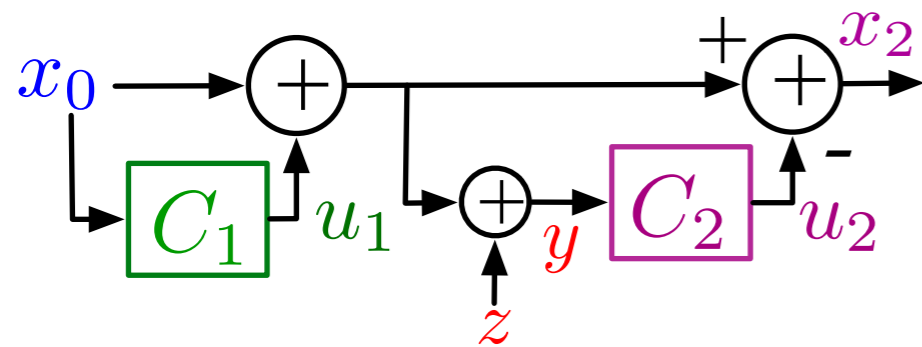

Witsenhausen's counterexample

communicating an evolving source

- [Wong, Brockett '90]
- [Borkar, Mitter '95]
- [Tatikonda, Mitter '01]
- [Sahai, Mitter '02]
- [Martins, Dahleh '08]
- [Yüksel, Başar '11]

What problems could we address now?

Goal: control a system using decentralized connected controllers

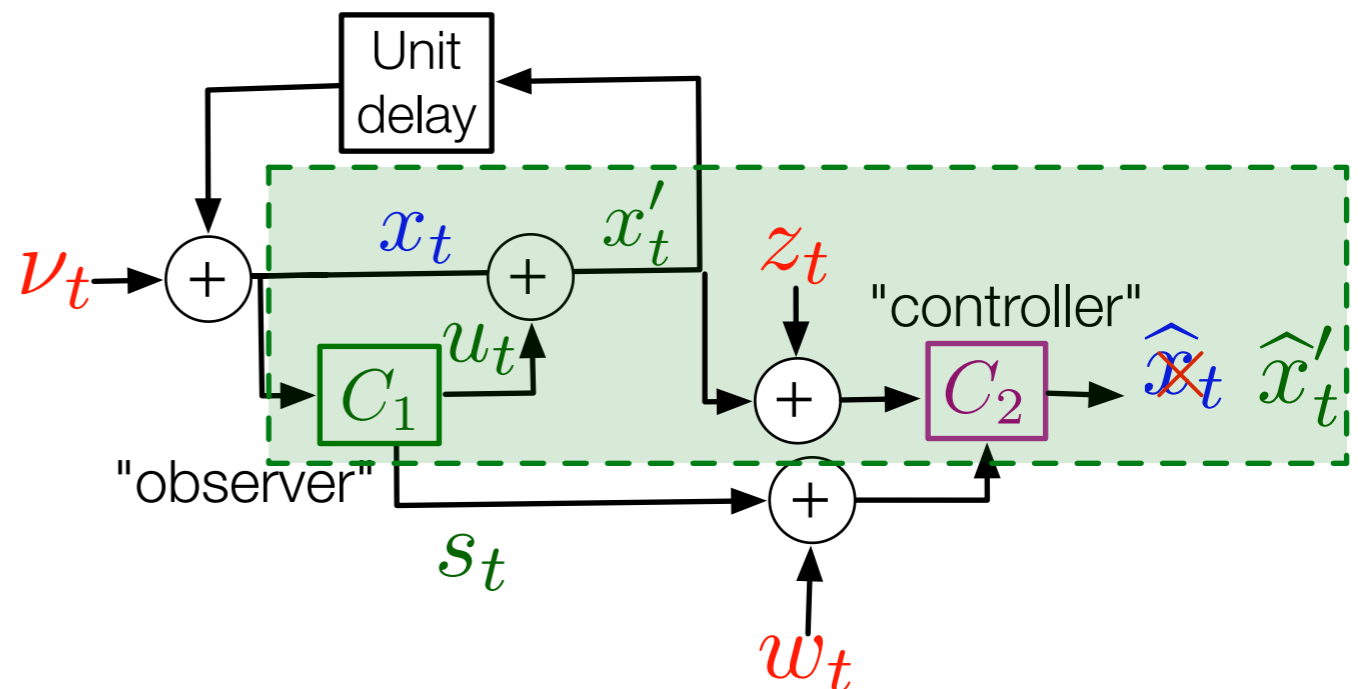
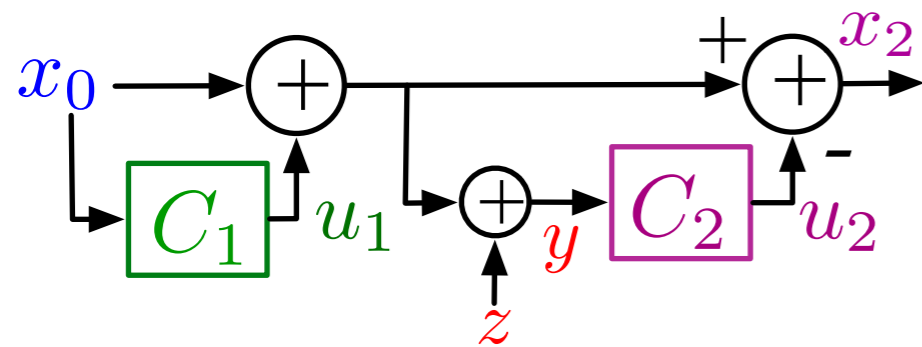

Witsenhausen's counterexample

communicating an evolving source

- [Wong, Brockett '90]
- [Borkar, Mitter '95]
- [Tatikonda, Mitter '01]
- [Sahai, Mitter '02]
- [Martins, Dahleh '08]
- [Yüksel, Başar '11]

What problems could we address now?

Goal: control a system using decentralized connected controllers

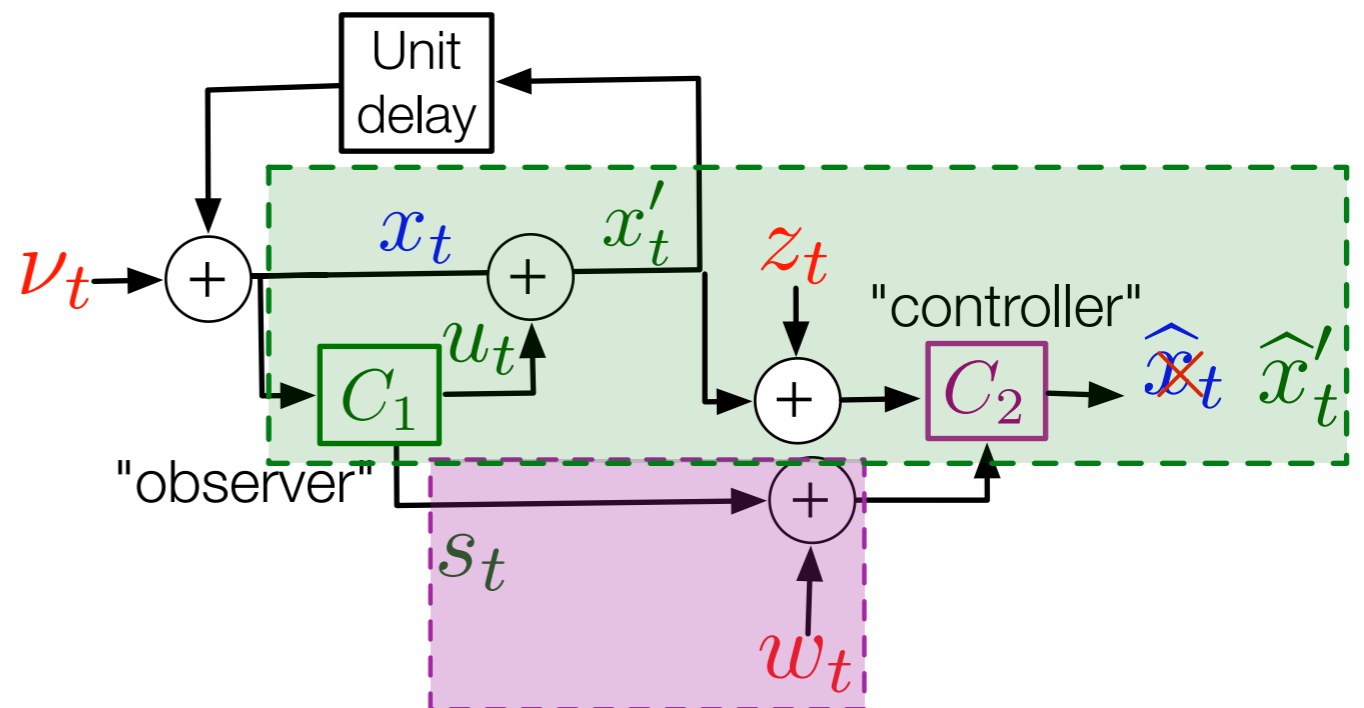
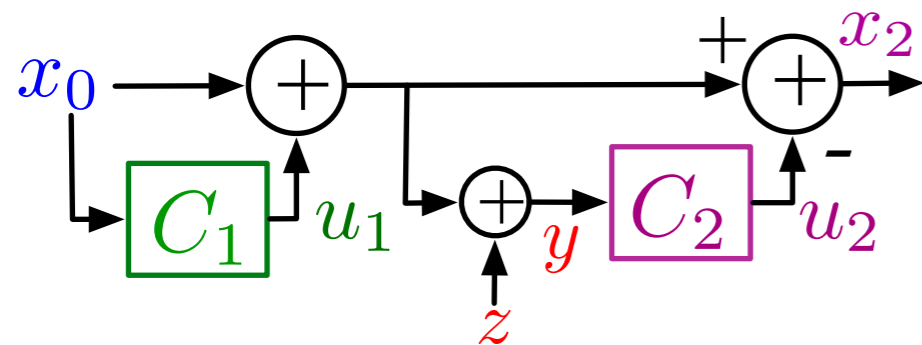

Witsenhausen's counterexample

communicating an evolving source

- [Wong, Brockett '90]
- [Borkar, Mitter '95]
- [Tatikonda, Mitter '01]
- [Sahai, Mitter '02]
- [Martins, Dahleh '08]
- [Yüksel, Başar '11]

What problems could we address now?

Goal: control a system using decentralized connected controllers

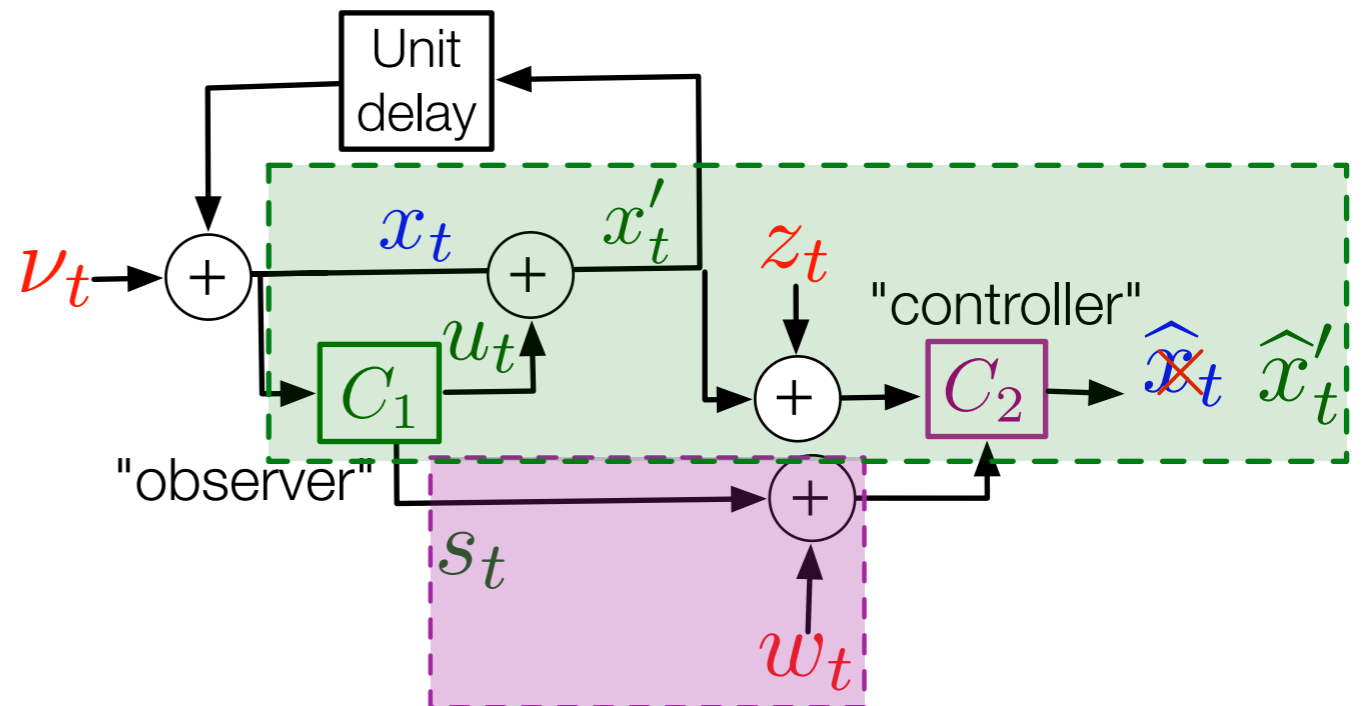
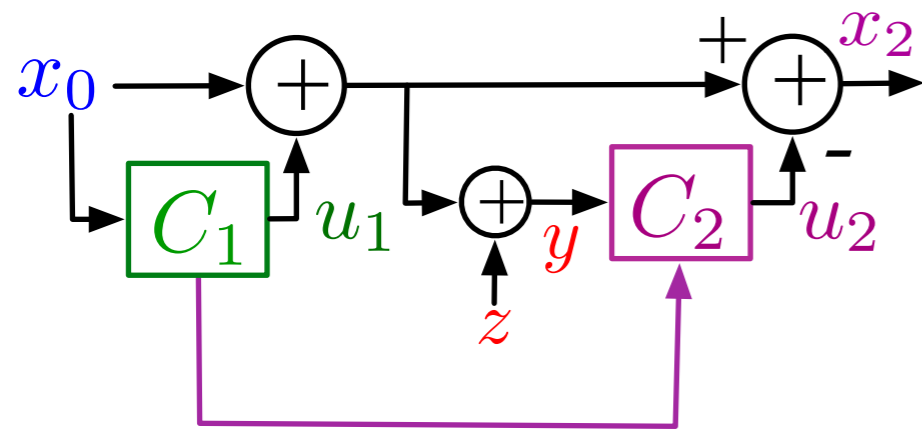

Witsenhausen's counterexample

communicating an evolving source

- [Wong, Brockett '90]
- [Borkar, Mitter '95]
- [Tatikonda, Mitter '01]
- [Sahai, Mitter '02]
- [Martins, Dahleh '08]
- [Yüksel, Başar '11]

What problems could we address now?

Goal: control a system using decentralized connected controllers

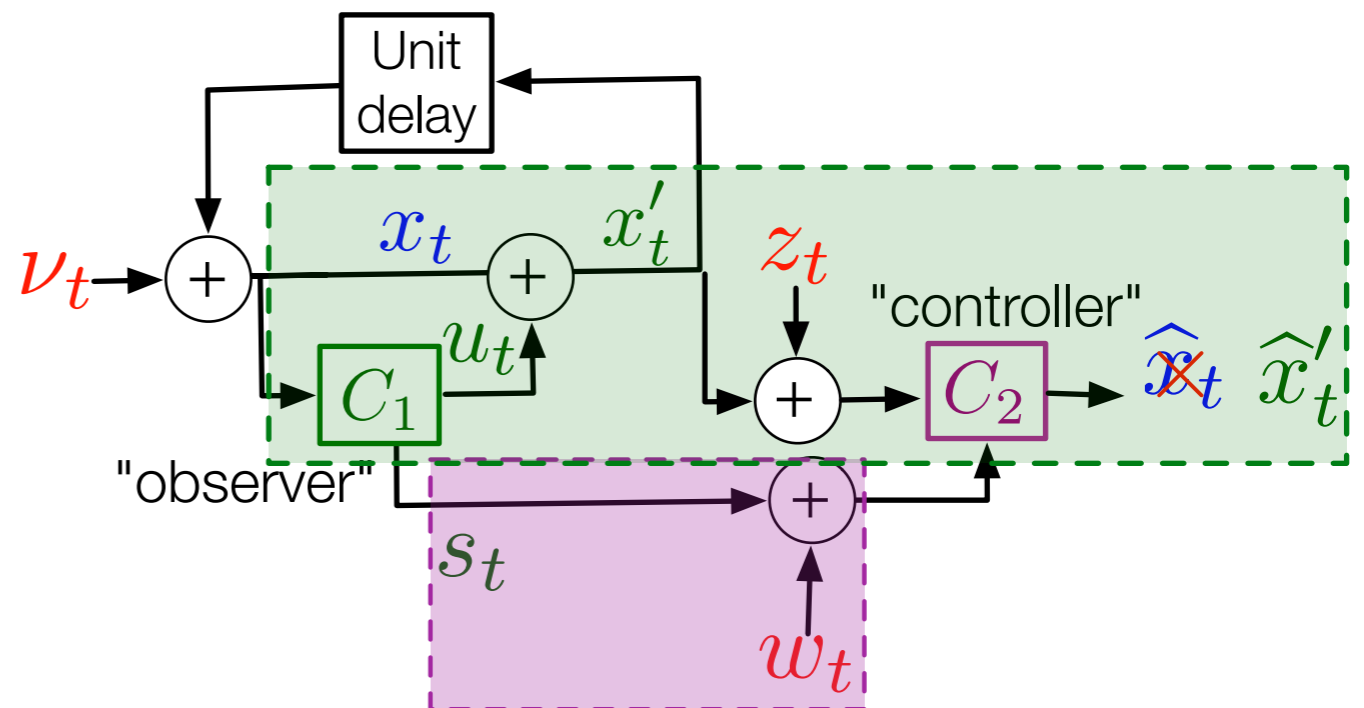
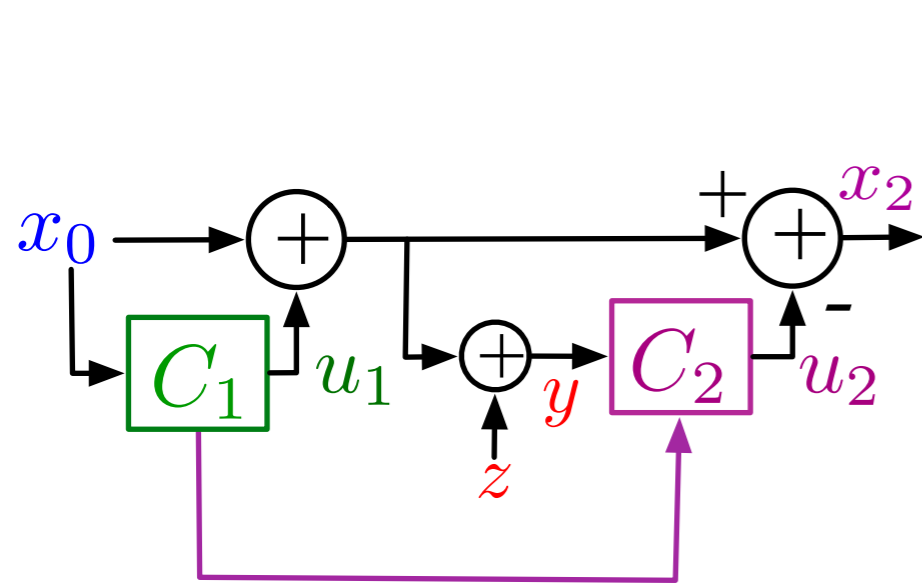

Witsenhausen's counterexample "actively" communicating an evolving source

- [Wong, Brockett '90]
- [Borkar, Mitter '95]
- [Tatikonda, Mitter '01]
- [Sahai, Mitter '02]
- [Martins, Dahleh '08]
- [Yüksel, Başar '11]

Witsenhausen's Counterexample can help understand these larger problems