

Capacity Results for Finite-Field Relay Networks

Piyush Gupta

**Mathematical & Algorithmic Sciences Center
Bell Labs, Lucent Technologies
Murray Hill, NJ**

Joint work with Sandeep Bhadra and Sanjay Shakkottai, UT-Austin

Outline

- Introduction
 - Network coding
 - Wireless models – broadcast erasure networks
- Our system model
 - Finite-field operations
 - Both broadcast and interference constraints
- Upper bound
- Network coding strategy
 - Achieves rates asymptotically close to u.b.
- Capacity gains due to fading

Network Coding – Wireline Networks

- All links at rate 1
- Single-source multicast

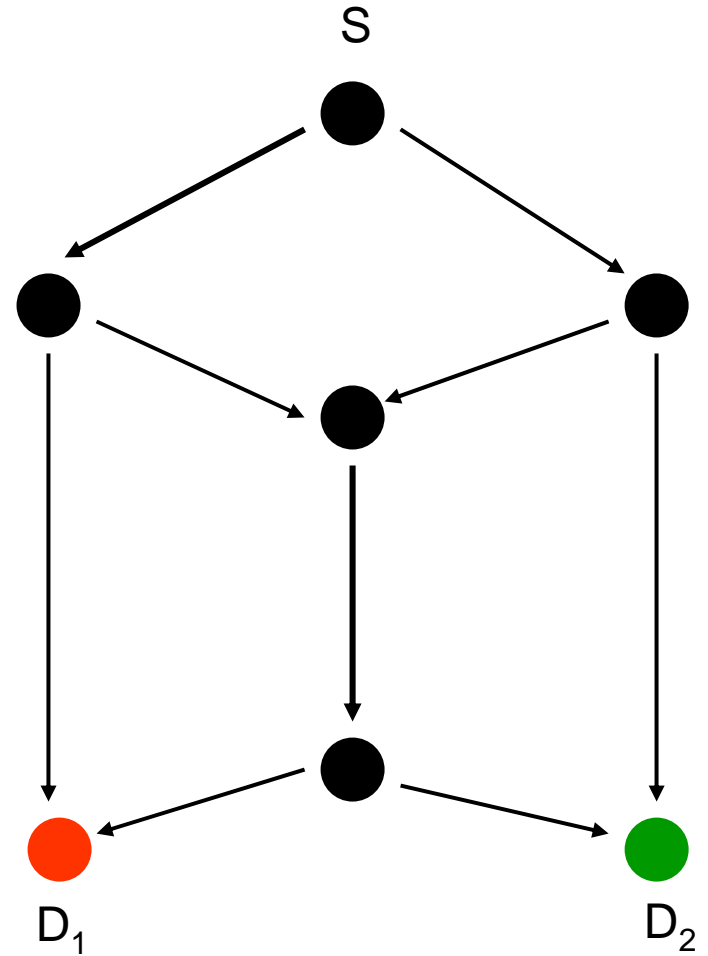

Network Coding – Wireline Networks

- All links at rate 1
- Single-source multicast
- Upper bound on rate R for each destination is 2
 - Same as min-cut

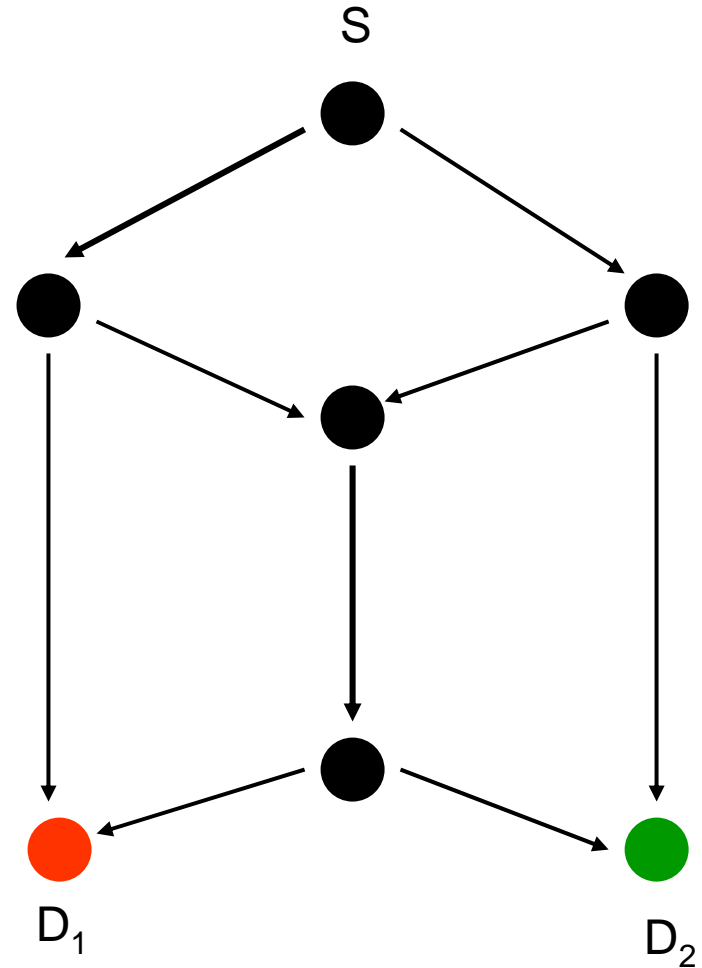

Network Coding – Wireline Networks

- All links at rate 1
- Single-source multicast
- Upper bound on rate R for each destination is 2
 - Same as min-cut
- Routing cannot achieve this
 - If $? = b$, D_2 only receives b

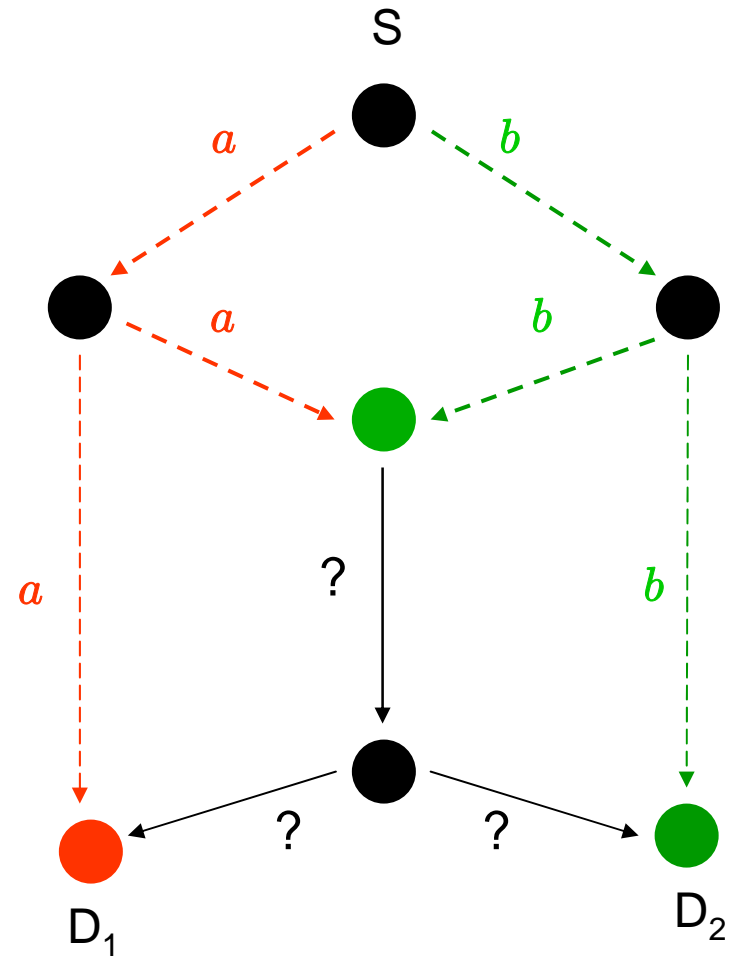

Network Coding – Wireline Networks

- All links at rate 1
- Single-source multicast
- Upper bound on rate R for each destination is 2
 - Same as min-cut
- Routing cannot achieve this
 - If $a = b$, D_2 only receives b
- **Network coding can**
 - By coding at intermediate node

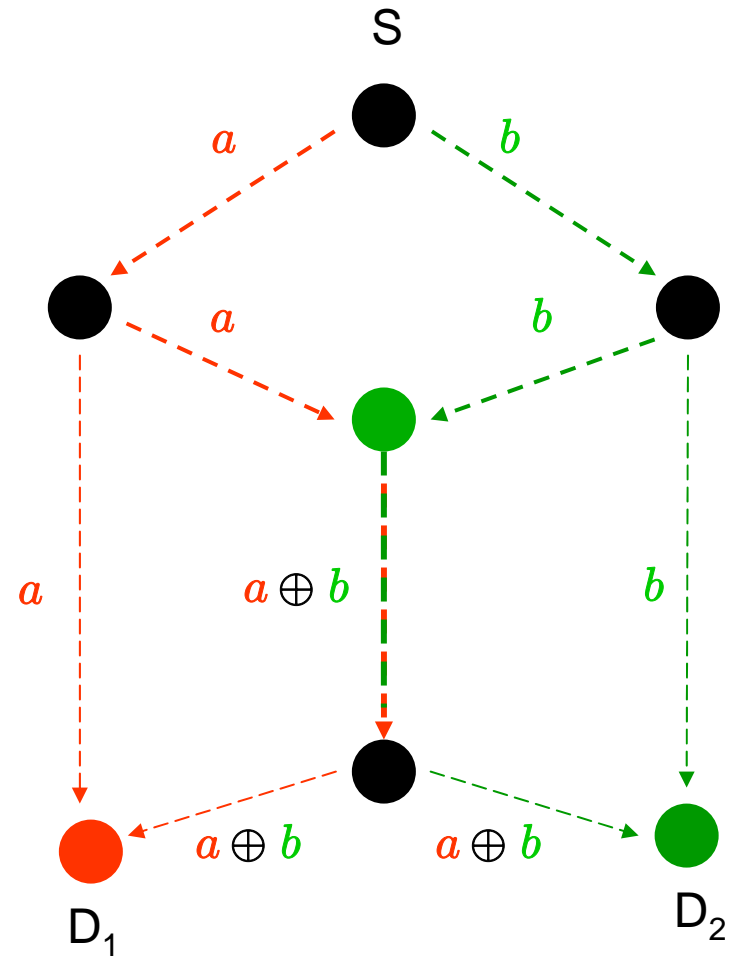

Network Coding – General Wireline Networks

Theorem [AhCaLiYe00]: Multicast capacity = $\min_i \{ \text{min-cut for } D_i \}$

- **Upper bound**
 - Min-cut bound for each D_i
- **Achievability** [Ho et al 03]
 - Source sends messages from F_q
 - Nodes perform **Random Linear Coding (RLC)** over received messages:
 $C = \alpha_1 a + \alpha_2 b, \alpha_i \in F_q$
 - D_1 decodes source messages from received vectors: $Y_1 = (Y_{11}=a, Y_{12}=C)$
 - Achieves rates arbitrarily close to min-cut bound for sufficiently large q

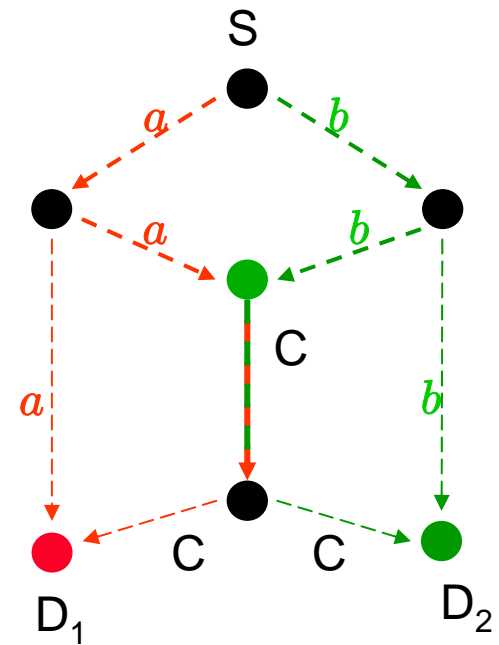

$$Y_1 = \begin{bmatrix} 1 & 0 \\ \alpha_1 & \alpha_2 \end{bmatrix} \begin{bmatrix} a \\ b \end{bmatrix}$$

Broadcast Erasure Networks (BEN)

- Directed graph $G=(V,E)$
- Each link $e \in E$ is independent **erasure channel**
 - $P(Y_{14} | X_1, X_2) = P(Y_{14} | X_1)$

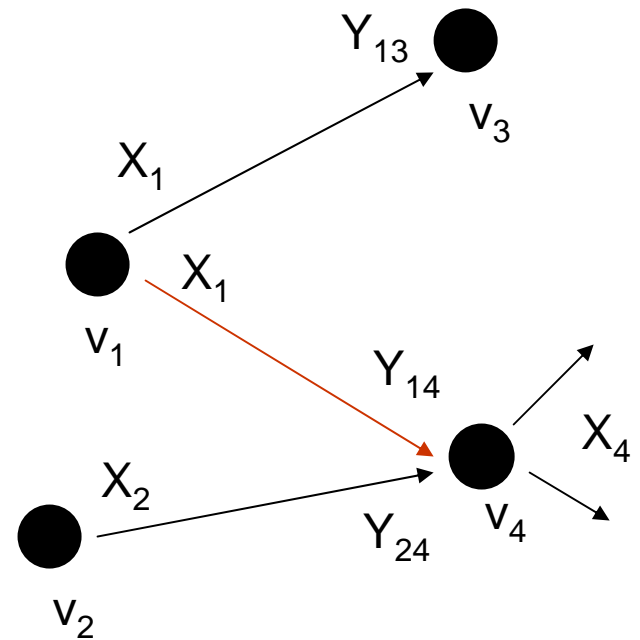

Broadcast Erasure Networks (BEN)

- Directed graph $G=(V,E)$
- Each link $e \in E$ is independent erasure channel
 - $P(Y_{14} | X_1, X_2) = P(Y_{14} | X_1)$
- **Broadcast** constraint
 - v_1 must send **same** X_1 along both (v_1, v_3) and (v_1, v_4)

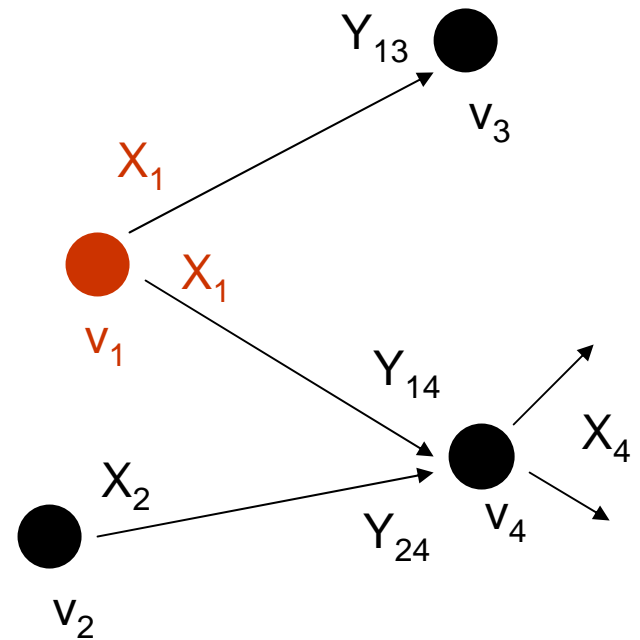

Broadcast Erasure Networks (BEN)

- Directed graph $G=(V,E)$
- Each link $e \in E$ is independent erasure channel
 - $P(Y_{14} | X_1, X_2) = P(Y_{14} | X_1)$
- Broadcast constraint
 - v_1 must send same X_1 along both (v_1, v_3) and (v_1, v_4)
- **Coding** at each node
 - $X_4 = f(Y_{14}, Y_{24})$

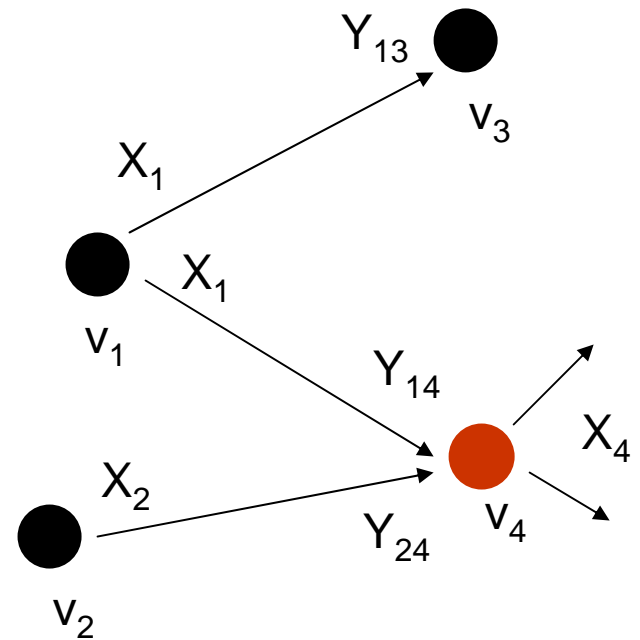

Broadcast Erasure Networks (BEN)

- Directed graph $G=(V,E)$
- Each link $e \in E$ is independent erasure channel
 - $P(Y_{14} | X_1, X_2) = P(Y_{14} | X_1)$
- Broadcast constraint
 - v_1 must send same X_1 along both (v_1, v_3) and (v_1, v_4)
- Coding at each node
 - $X_4 = f(Y_{14}, Y_{24})$

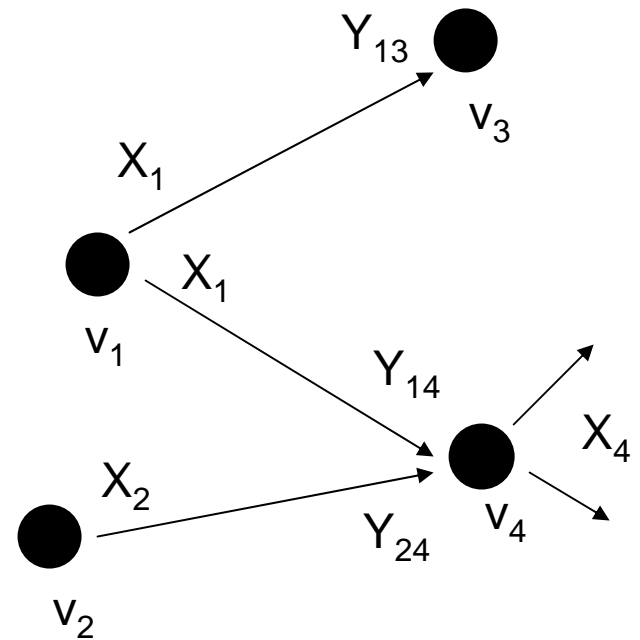

Does not model interference

Broadcast Erasure Networks -- Capacity

- Results for directed acyclic graphs
- **Theorem** [DanGow04, LunMed04]:
Capacity = $\min_i \{ \text{generalized min-cut for } D_i \}$
 - e.g., $(1 - \varepsilon_{13}\varepsilon_{14}) + (1 - \varepsilon_{24})$
- Upper bound
 - Follows from min-cut bound
 $\min_{\text{cut}} I(X_{\text{cut-l}}; Y_{\text{cut-r}} | X_{\text{cut-r}})$
- Achievability
 - [DanGow04] Random coding at nodes
 - need to keep track of erasure patterns
 - [LunMed04] model as Hypergraph, RLC at nodes
 - track flow of innovative packets
 - generalized to arbitrary arrival processes and correlated erasure patterns

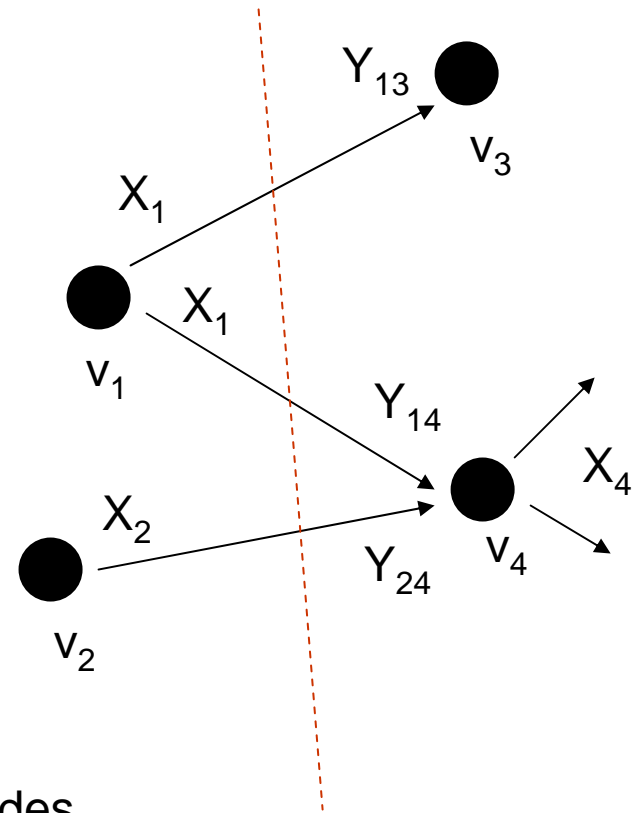

Wireless Broadcast and Interference Networks (WBAIN)

- Above and other results model broadcast but not **interference**
- Interference is challenging to analyze
- Capacity **not** known for even **simple** network configurations

– Single-relay channel

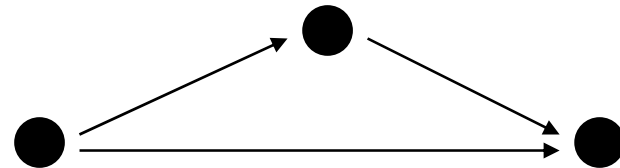

– Interference channel

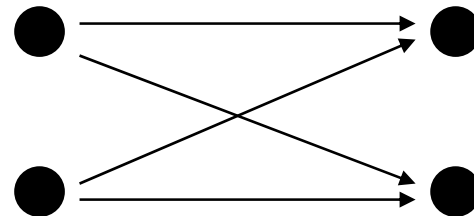

– ...

WBAIN – A Finite-Field Model

- Directed acyclic graph $G=(V,E)$
- **Broadcast** constraint
 - v_1 must send **same** X_1 along both (v_1, v_3) and (v_1, v_4)

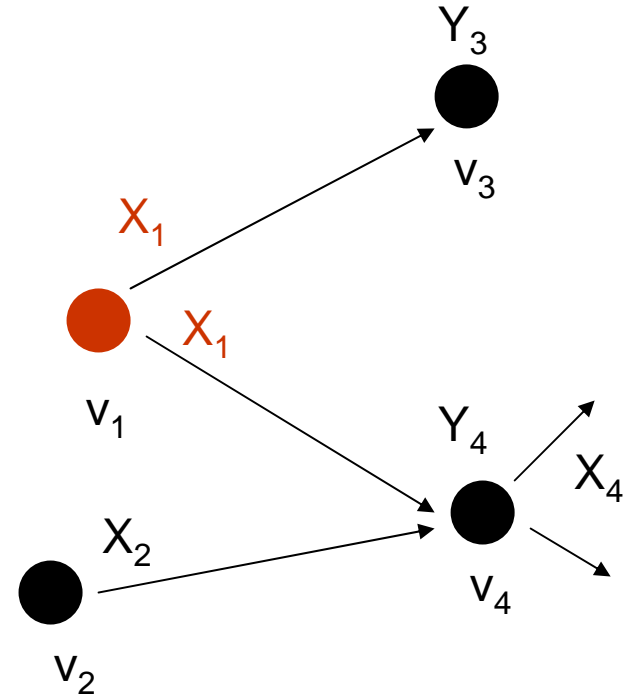

WBAIN – A Finite-Field Model

- Directed acyclic graph $G=(V,E)$
- Broadcast constraint
 - v_1 must send same X_1 along both (v_1, v_3) and (v_1, v_4)
- Model **power** constraint by **rate**
 - v_i can send at rate $\leq R_i$

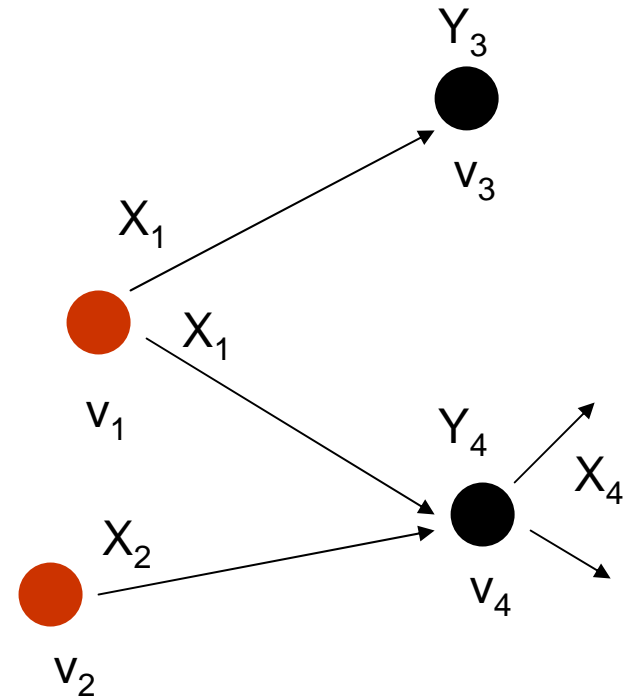

WBAIN – A Finite-Field Model

- Directed acyclic graph $G=(V,E)$
- Broadcast constraint
 - v_1 must send same X_1 along both (v_1, v_3) and (v_1, v_4)
- Model power constraint by rate
 - v_i can send at rate $\leq R_i$
- All **operations** over finite field F_q
 - Each node transmits vectors from F_q
 - $\log q \geq \max_i R_i$

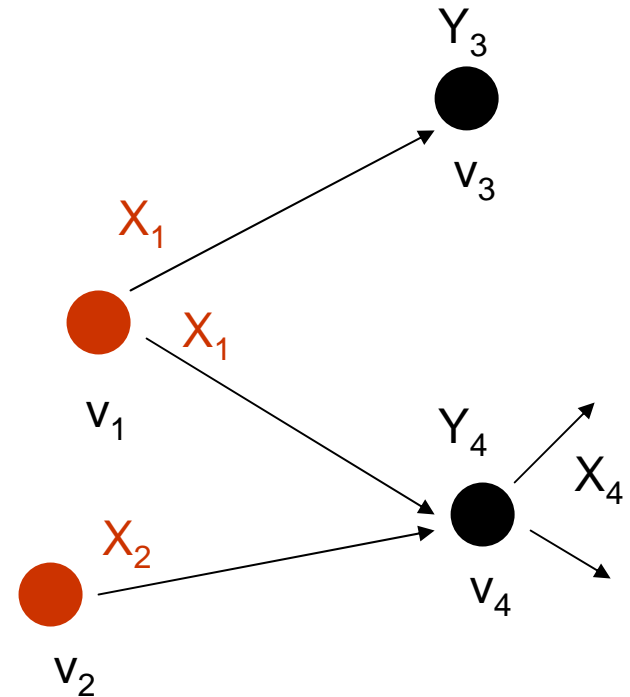

WBAIN – A Finite-Field Model

- Directed acyclic graph G
- Broadcast constraint
 - v_1 must send same X_1 along both (v_1, v_3) and (v_1, v_4)
- Model power constraint by rate
 - v_i can send at rate $\leq R_i$
- All operations over finite field F_q
 - Each node transmits vectors from F_q
 - $\log q \geq \max_i R_i$
- Two reception models
 - With or without fading

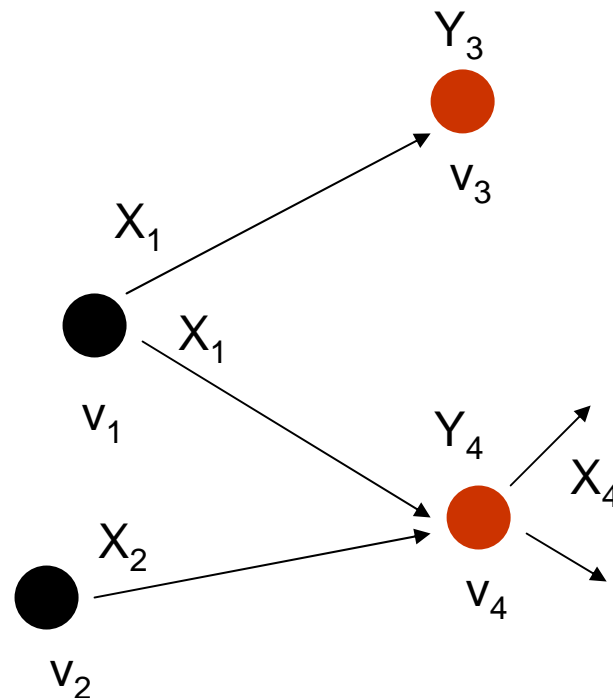

WBAIN – A Finite-Field Model (contd.)

- **Non-fading model:**

v_4 receives Y_4 , where Y_4

- $Y_4 = X_1 + X_2 \in \mathbb{F}_q$ with prob. $1 - \varepsilon_4$
- $Y_4 = \phi$ (erasure) with prob. ε_4
- Erasures are independent across receivers

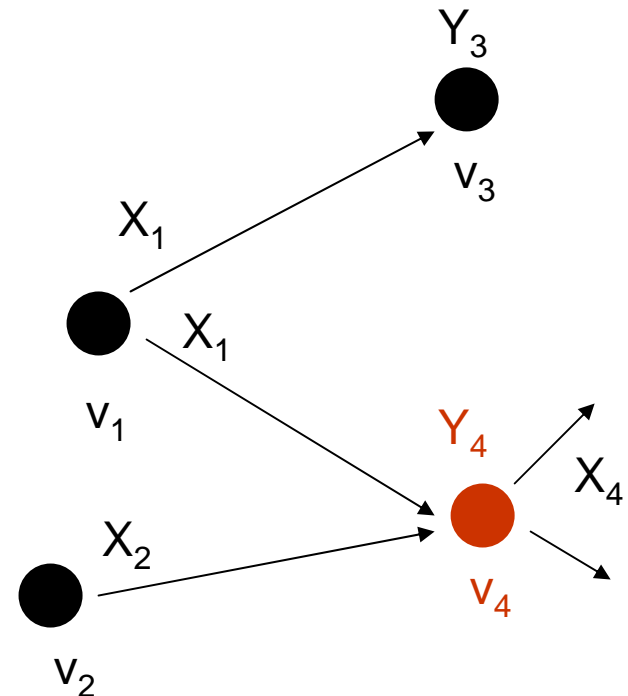

- **Fading model:**

As above, except when no erasure

- $Y_4 = h_{14} X_1 + h_{24} X_2$
- h_{ij} uniform i.i.d. over \mathbb{F}_q

Upper Bound on WBAIN Capacity

- Graph transformation $G \rightarrow T(G)$
 - Maps G to a **wireline** graph
- For each transmitting node $v_i \in G$
 - Add v'_i
 - Link (v_i, v'_i) of rate R_i
 - Models **broadcast** constraint

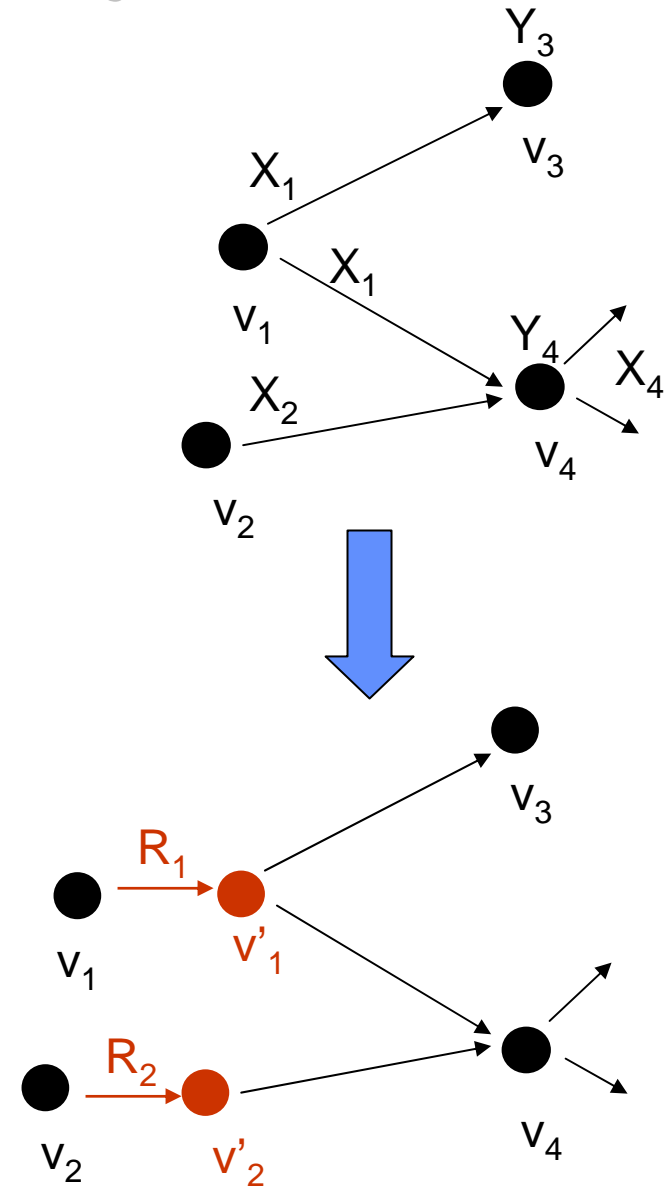

Upper Bound on WBAIN Capacity

- Graph transformation $G \rightarrow T(G)$
 - Maps G to a **wireline** graph
- For each transmitting node $v_i \in G$
 - Add v'_i
 - Link (v_i, v'_i) of rate R_i
 - Models **broadcast** constraint
- For each receiving node $v_r \in G$
 - Add v''_r
 - Link (v''_r, v_r) of rate $R_o = \log q$ and erasure probability ε_r
 - Models **MAC** constraint

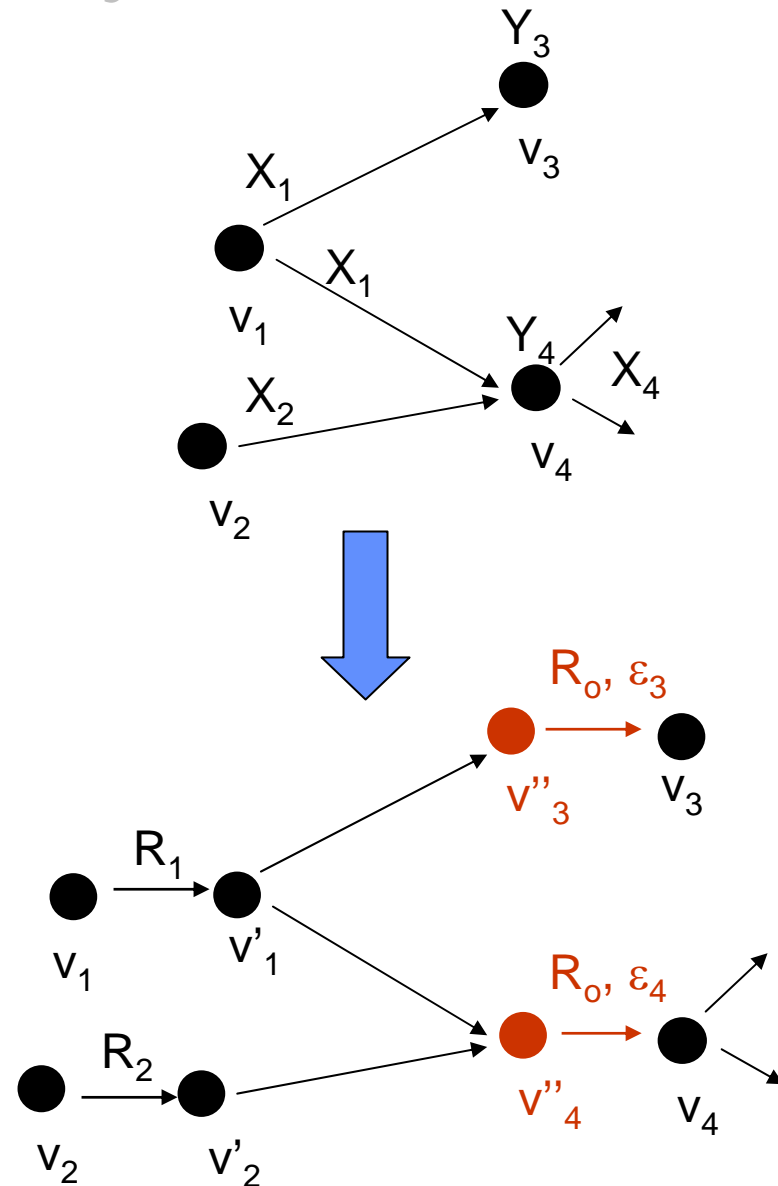

Upper Bound on WBAIN Capacity

- Graph transformation $G \rightarrow T(G)$
 - Maps G to a **wireline** graph
- For each transmitting node $v_i \in G$
 - Add v'_i
 - Link (v_i, v'_i) of rate R_i
 - Models **broadcast** constraint
- For each receiving node $v_r \in G$
 - Add v''_r
 - Link (v''_r, v_r) of rate $R_o = \log q$ and erasure probability ε_r
 - Models **MAC** constraint
- Wireless link (v_i, v_j) replaced by *wireline* link (v'_i, v''_j) of rate R_i

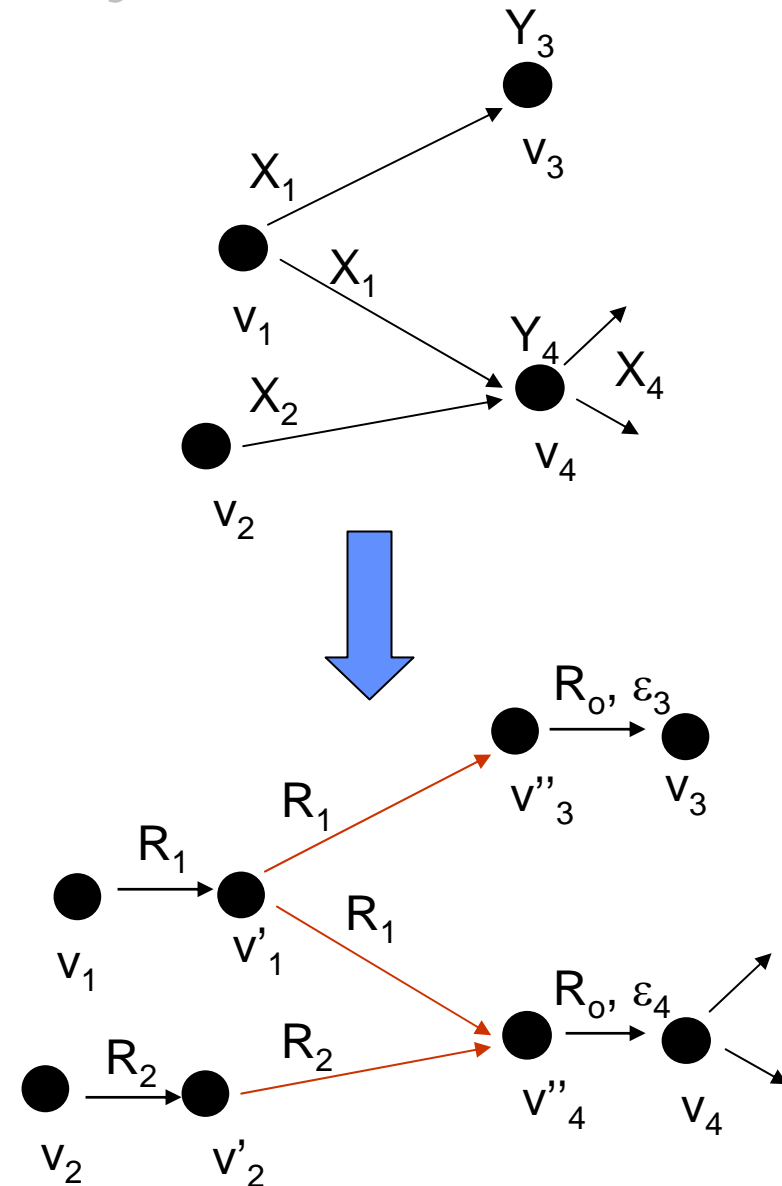

Upper Bound on WBAIN Capacity (contd)

- Theorem:**

$$\begin{aligned} \text{Capacity of WBAIN } G \text{ over } F_q, C_q \\ \leq \text{Capacity of wireline } T(G) \\ = \min_d \{ \text{min-cut of s-d in } T(G) \} =: C_s \end{aligned}$$

- Main steps:**

- Capacity region of finite-field MAC upper bounded by pentagon (O, A_1, B_1, B_2, A_2)

- (X_1, X_2) constitutes sufficient statistic for $h_{13} X_1 + h_{23} X_2$

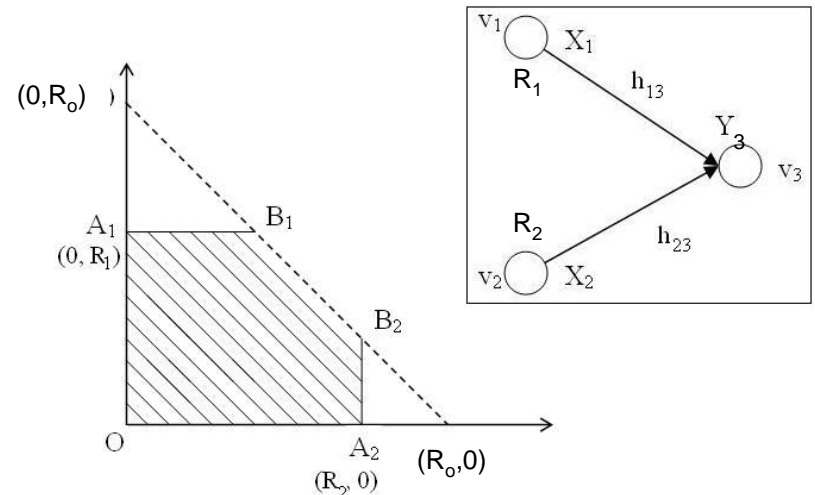

- Above bound holds for **both** fading and non-fading models

Improved Upper Bound on WBAIN with Fading

- Bound on capacity of finite-field MAC

$$\begin{aligned}
 C_3(q) &= \max_{\{H(X_i) \leq R_i\}} I(Y_3; X_1, X_2 | h_{13}, h_{23}) \\
 &= \max_{\{H(X_i) \leq R_i\}} H(Y_3 | h_{13}, h_{23}) - H(Y_3 | X_1, X_2, h_{13}, h_{23}) \\
 &= \max_{\{H(X_i) \leq R_i\}} H(h_{13}X_1 + h_{23}X_2 | h_{13}, h_{23}) - 0 \\
 &= q^{-2}((q-1)(R_1 + R_2) + (q-1)^2 \min \{R_1+R_2, \log q\}) \\
 &\leq (1-q^{-1})(R_1 + R_2)
 \end{aligned}$$

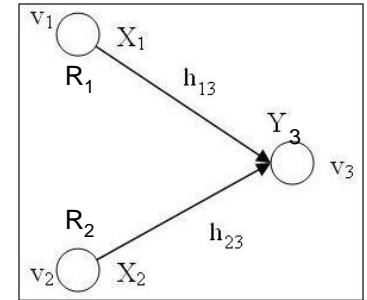

- Node \$i\$ receives transmissions from nodes in \$J\$

$$C_i(q) \leq (1 - q^{-1})(\sum_{j \in J} R_j)$$

- More generally, total rate across cut \$U\$ bounded by

$$\begin{aligned}
 C_U(q) &\leq \max_{\{H(X_i) \leq R_i\}} I(Y_3, Y_4; X_1, X_2 | H_{1,2,3,4}) \\
 &\leq \sum_i (1-q^{-\delta_i}) R_i
 \end{aligned}$$

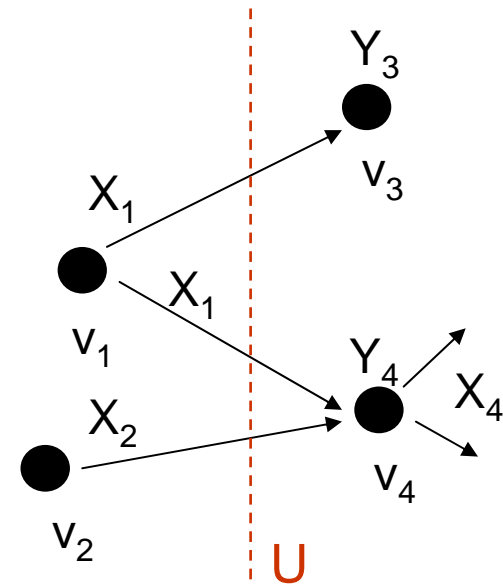

Improved Upper Bound (contd.)

- Consider Broadcast Erasure Network $T'(G)$ having same topology and rates as G , with
 - **no** interference, e.g., Y_4 receives (X_1, X_2)

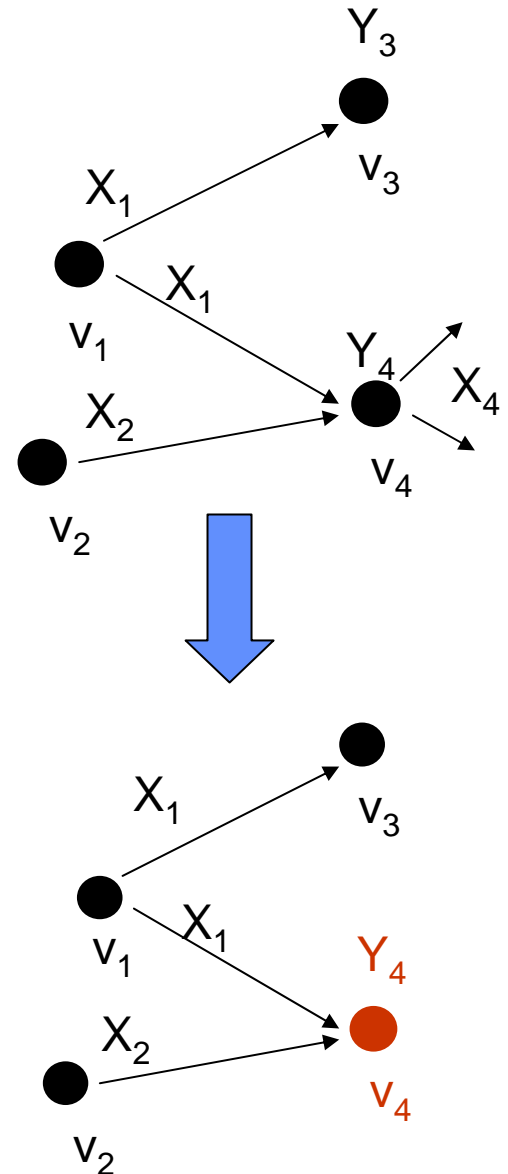

Improved Upper Bound (contd.)

- Consider Broadcast Erasure Network $T'(G)$ having same topology and rates as G , with
 - no interference, e.g., Y_4 receives (X_1, X_2)
 - each broadcast link has independent erasures with probability q^{-1} , e.g., $(1,3)$, $(1,4)$, $(2,4)$

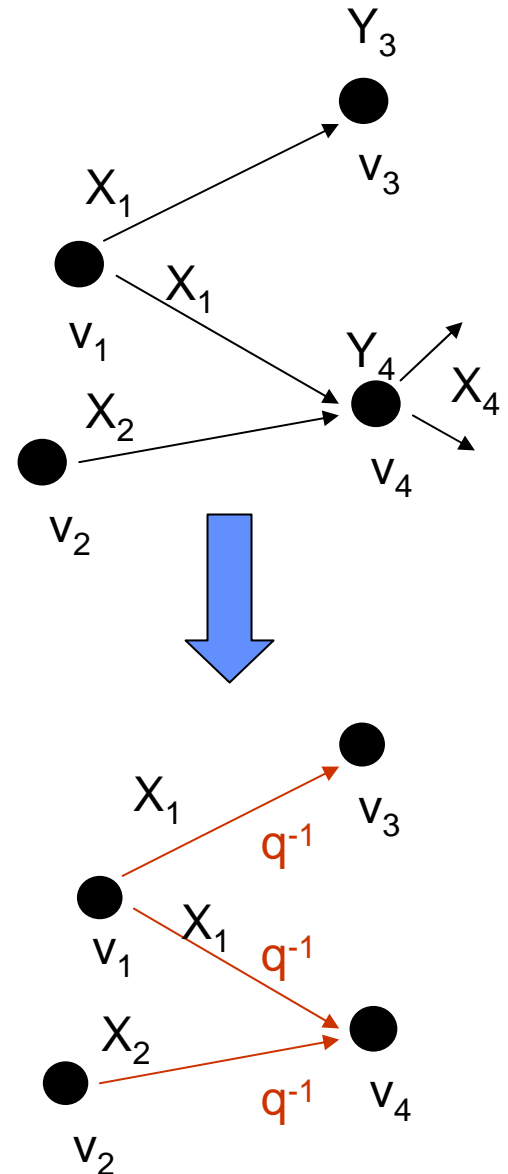

Improved Upper Bound (contd.)

- Consider Broadcast Erasure Network $T'(G)$ having same topology and rates as G , with
 - no interference, e.g., Y_4 receives (X_1, X_2)
 - each broadcast link has independent erasures with probability q^{-1} , e.g., $(1,3)$, $(1,4)$, $(2,4)$
 - receiving node erasures mapped to aux. edge erasures

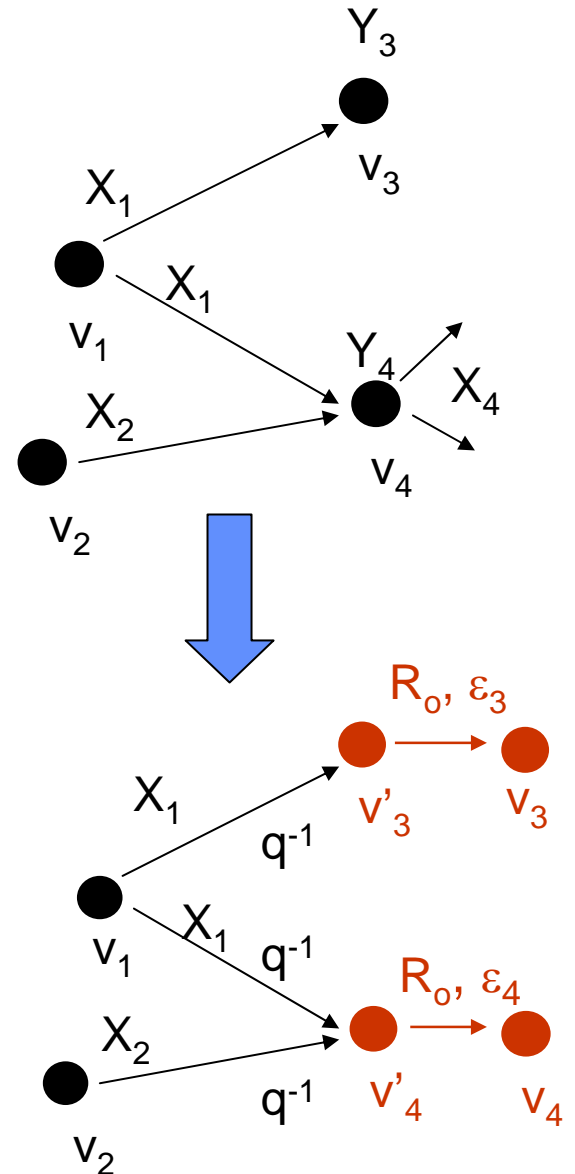

Improved Upper Bound (contd.)

- Consider Broadcast Erasure Network $T'(G)$ having same topology and rates as G , with
 - no interference, e.g., Y_4 receives (X_1, X_2)
 - each broadcast link has independent erasures with probability q^{-1} , e.g., $(1,3)$, $(1,4)$, $(2,4)$
 - receiving node erasures mapped to aux. edge erasures

- **Theorem:** Capacity of WBAIN G over F_q , $C_q \leq$ Capacity of BEN, $T'(G)$, $C_s'(q) = \min_i \{ \text{generalized min-cut for } D_i \}$

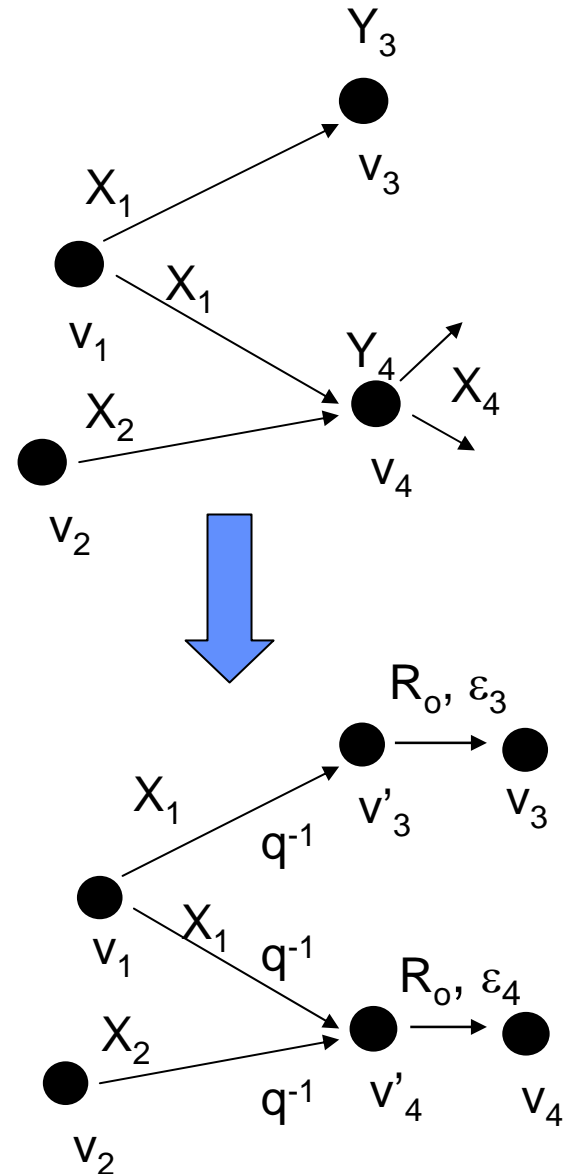

Improved Upper Bound (contd.)

- Consider Broadcast Erasure Network $T'(G)$ having same topology and rates as G , with
 - no interference, e.g., Y_4 receives (X_1, X_2)
 - each broadcast link has independent erasures with probability q^{-1} , e.g., $(1,3)$, $(1,4)$, $(2,4)$
 - receiving node erasures mapped to aux. edge erasures

• **Theorem:** Capacity of WBAIN G over F_q , $C_q \leq$ Capacity of BEN, $T'(G)$, $C_s'(q) = \min_i \{\text{generalized min-cut for } D_i\}$

• $C_s'(q) \leq C_s \cdot (1 - O(q^{-\max \delta_i})) < C_s$

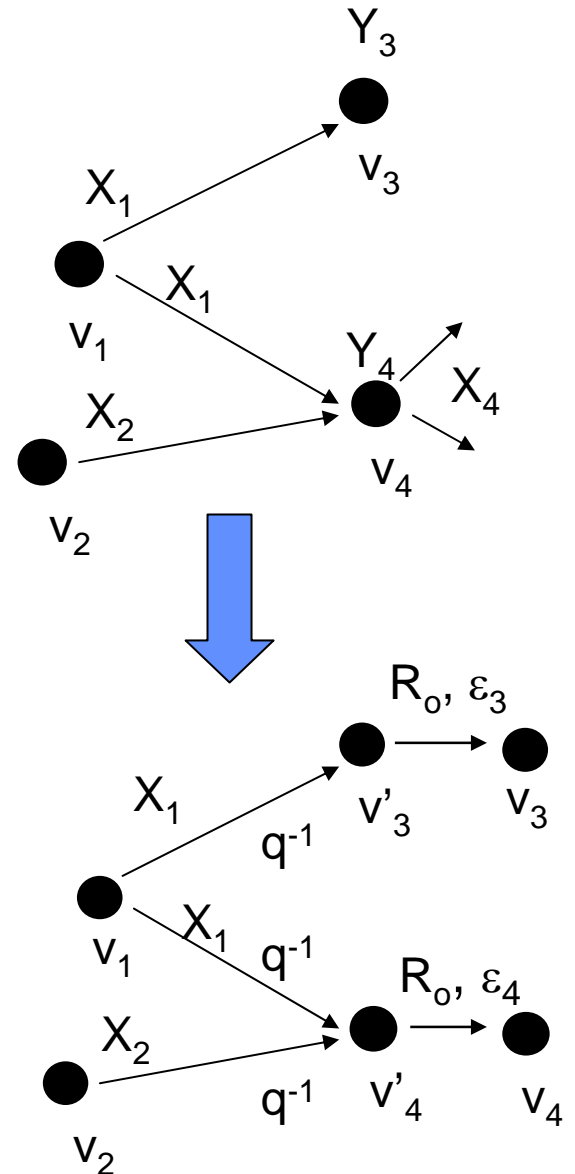

Coding Strategy for WBAIN with Fading

- For any $\delta > 0$, there exists **flow vector** $\{f_p\}$ for all paths $\{p\}$ between s-d in BEN $T'(G)$ such that
 - $\sum_p f_p = C_s' \cdot (1-\delta)$
 - $\sum_{p: v_i \in p} f_p / (1-\varepsilon_{h(v_i,p)}) \leq R_i \cdot (1-\delta)$
 - $h(v_i,p)$ is next hop from i on path p
- Coding strategy:
 - Source s gets messages at rate $C_s' \cdot (1-\delta)$
 - s injects **RLC** of received messages on path p at rate $f_p / (1-\varepsilon_{h(s,p)})$
 - Node v_i injects **RLC** of received messages at rate $\sum_{p: v_i \in p} f_p / (1-\varepsilon_{h(v_i,p)})$
- **Theorem:** $C_s' \cdot (1-O(1/q)) \cdot (1-\delta)$ is **achievable** in G with uniform i.i.d. fading

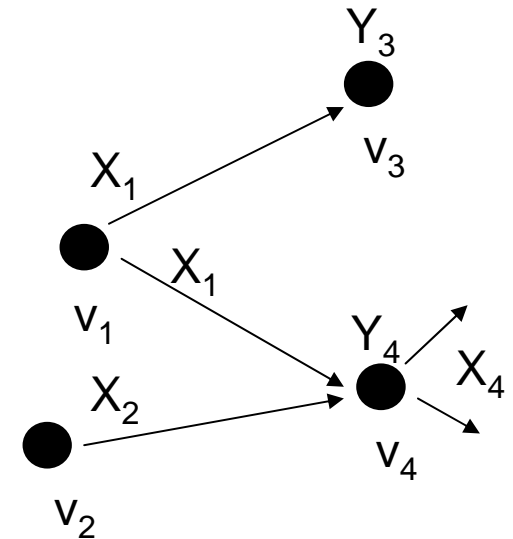

Coding Strategy for WBAIN with Fading (contd)

Main steps in achievability proof:

- Track the flow of **innovative** packets
- Fading **helps** to maintain innovation rates over different links in a cut
 - in spite of broadcast and interference
- “Bad” fading at node v_j -- $h_j = (h_{ij})_i = 0$ or dependent on $\{h_k\}$ -- **reduces** rate of innovation by **at most** $(1 - O(1/q))$
- At each hop of path p the rate of innovation is **at least** $g_p = f_p(1 - O(N_o/q))$
 - $N_o =$ diameter of G
- Achieved rate = $\sum_p g_p = C_s' \cdot (1 - O(N_o/q)) \cdot (1 - \delta)$

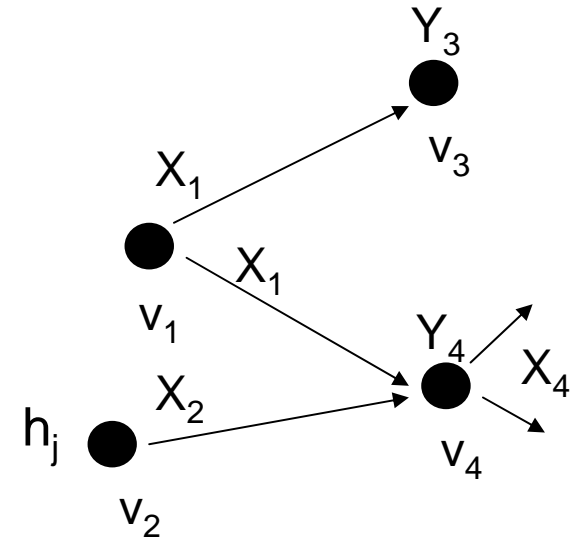

Tight bounds on Capacity of WBAIN with fading

Theorem: $C_s' \cdot (1 - O(1/q)) \leq C_q \leq C_s'$

- Also holds for **heterogenous** networks having **both** wireless and wireline links:
 - Each node can have both types of incoming and outgoing links
 - Node receives weighted sum of vectors sent over incident *wireless* links, $Y_4 = h_{14}X_1 + h_{24}X_2$
 - Node receives separate information over incoming *wireline* links, $Y_7 = (X_5, X_6)$
 - Similarly, when node transmits

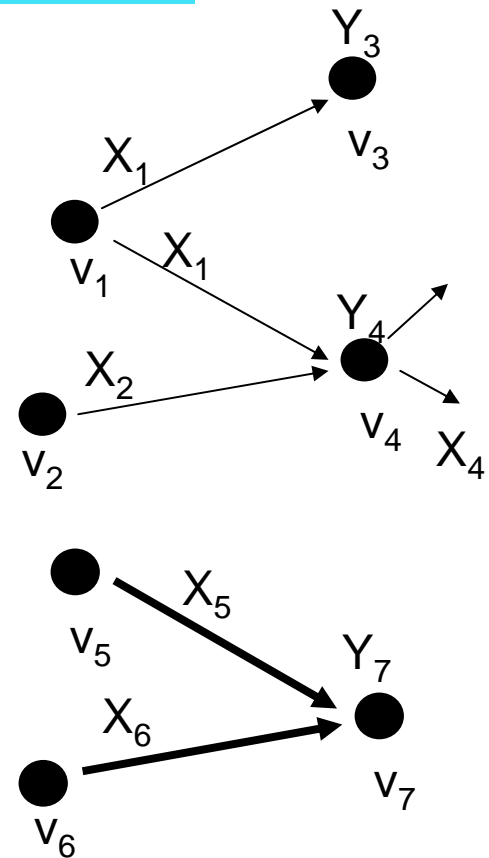

Capacity Gains due to Fading – An Example

- Heterogenous network: wireless at cut U , wireline otherwise

- R_1 and q s.t. U is bottleneck cut

- e.g., $R_1 = \log q$

- Upper bound:

$$C_s' \sim \sum_{i=1}^5 R_1(1-\varepsilon_i) = R_1(5-\sum_i \varepsilon_i)$$

- Fading: our strategy achieves

$$C_s' \cdot (1-O(1/q))(1-\delta)$$

- No fading: capacity is bounded by

$$R_1(1-\prod_i \varepsilon_i)$$

- ~ 5-fold increase in capacity with fading

- Higher for graphs with larger bottleneck cut

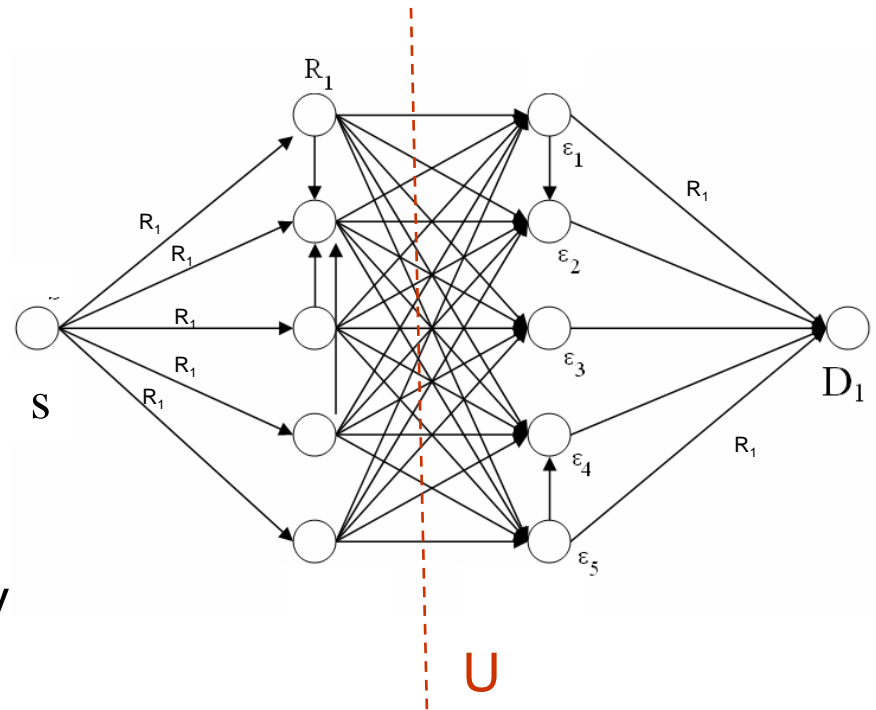

Summary and Future Work

- Finite-field model of relay networks
 - All operations over a finite field
 - Incorporates **both** broadcast and interference constraints
 - Allows for **fading**
- Asymptotically **tight bounds** on capacity for uniform iid fading
 - Upper bound based on results for Broadcast Erasure Networks
 - Achievability through network coding

Some Interesting Issues

- **Non-uniform** fading?
- Achievable rates under no fading?
- What, if anything, can we infer about **Gaussian** channels?