

**Diversity and Freedom:
A Fundamental Tradeoff in Multiple Antenna Channels**

Lizhong Zheng and David Tse
Department of EECS, U.C. Berkeley

July, 2002

EPFL

Wireless Fading Channel

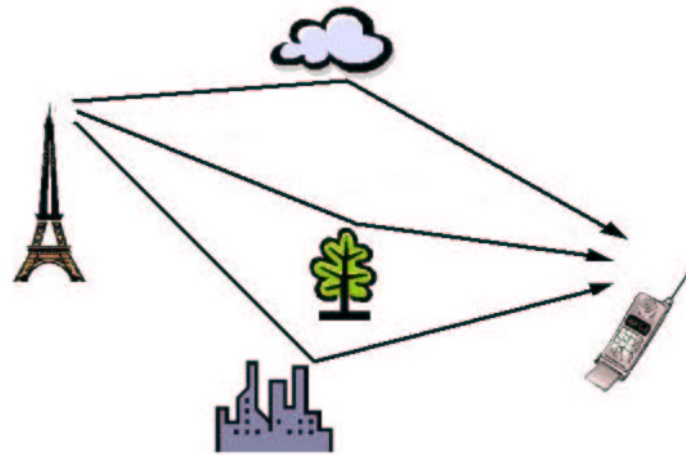

- Fundamental characteristic of wireless channels: **multi-path fading**.

Wireless Fading Channel

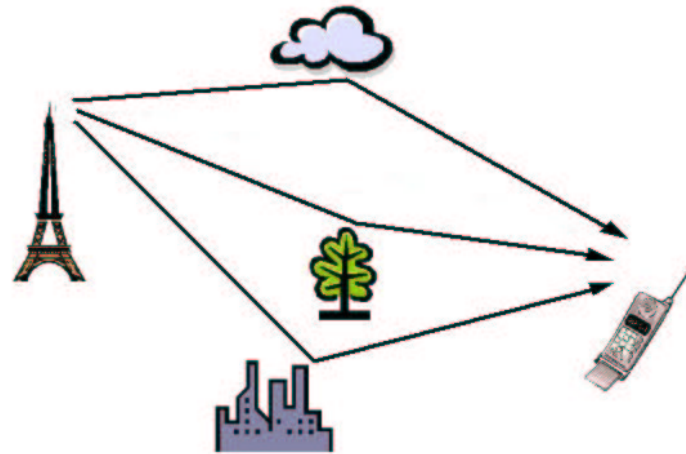

- Fundamental characteristic of wireless channels: **multi-path fading**.
- Two different views of fading have emerged.

View #1: Fading is Bad

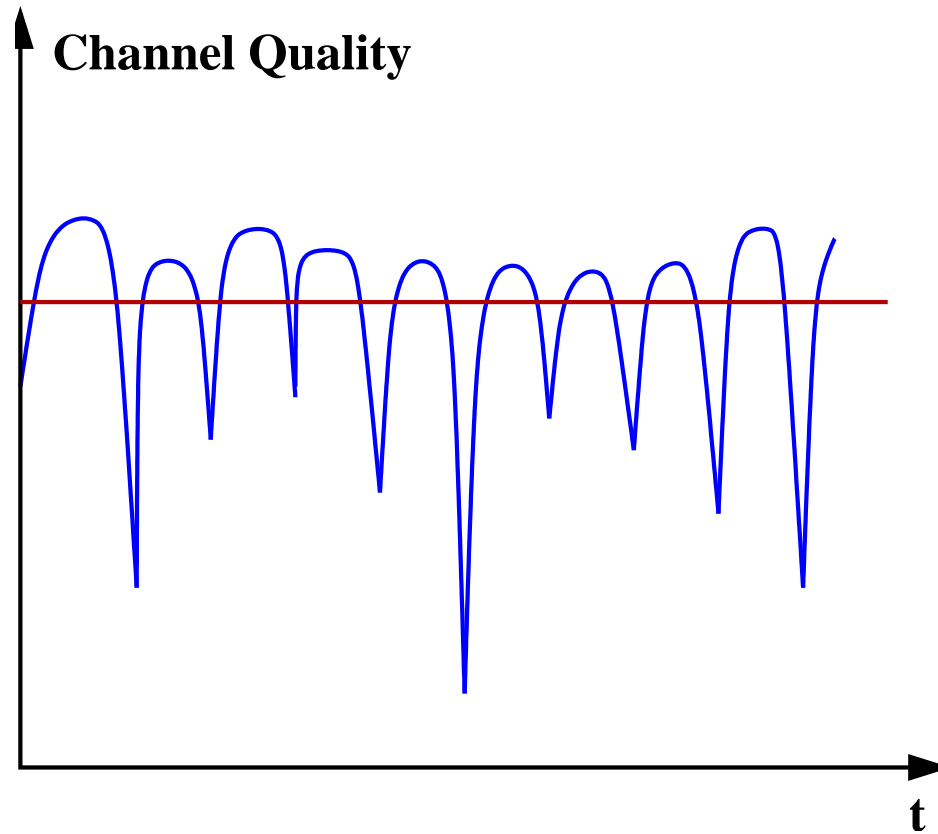

Fading Channels have **poor reliability**

Diversity



Diversity

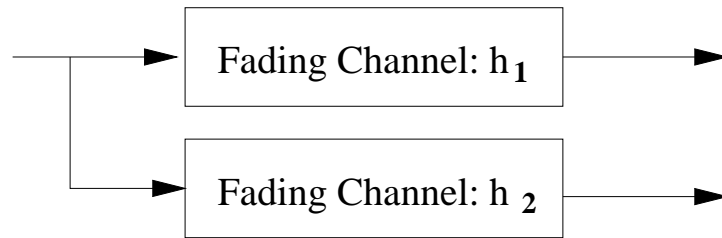

- Additional independent fading channels increase **diversity**.

Diversity

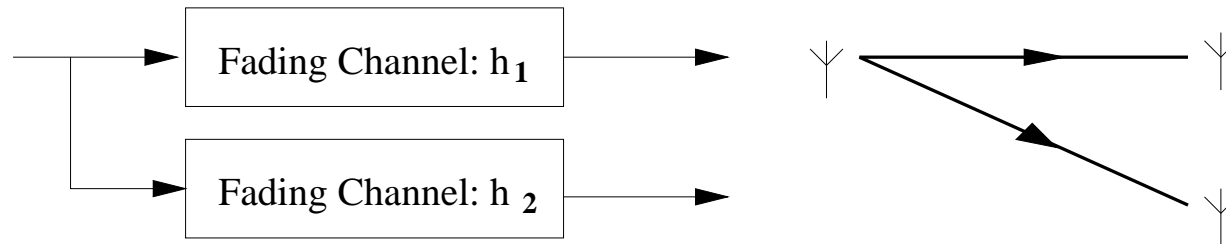

- Additional independent fading channels increase **diversity**.
- Spatial diversity

Diversity

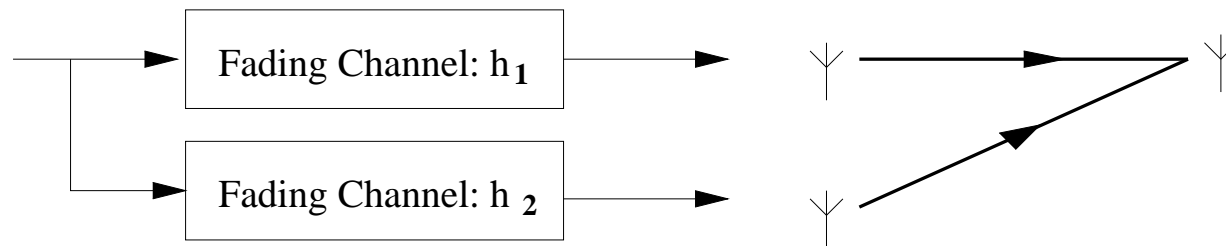

- Additional independent fading channels increase **diversity**.
- Spatial diversity: receive, transmit

Diversity

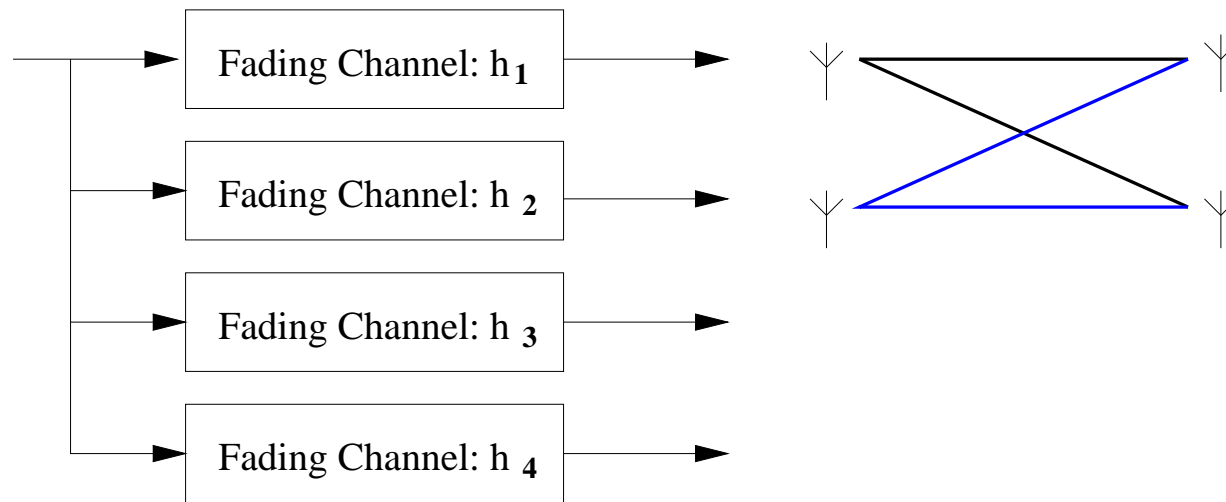

- Additional independent fading channels increase **diversity**.
- Spatial diversity: receive, transmit or both.

Diversity

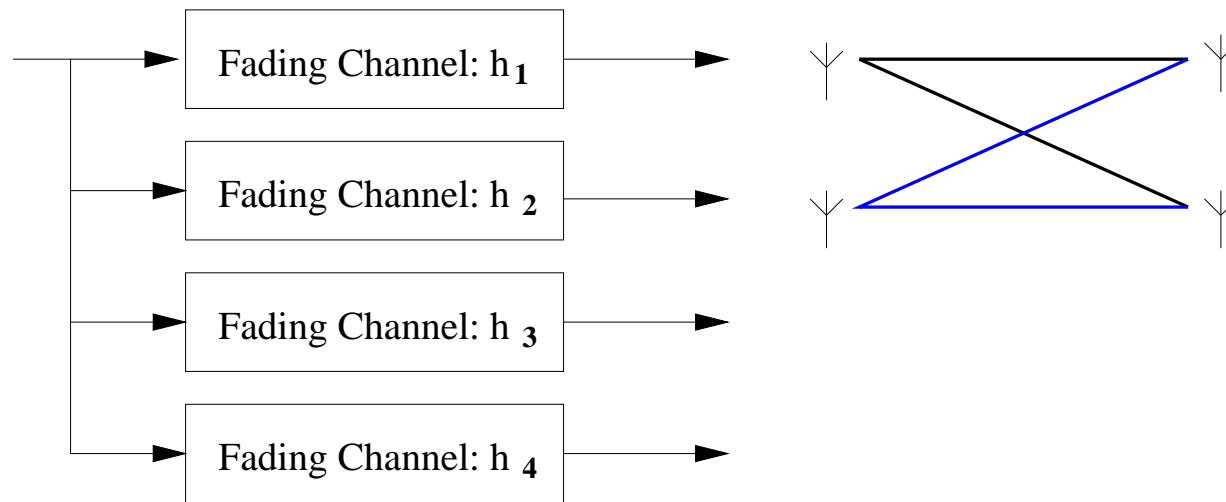

- Additional independent fading channels increase **diversity**.
- Spatial diversity: receive, transmit or both.
- **Repeat and Average**: compensate against channel unreliability.

View #2: Fading is Good

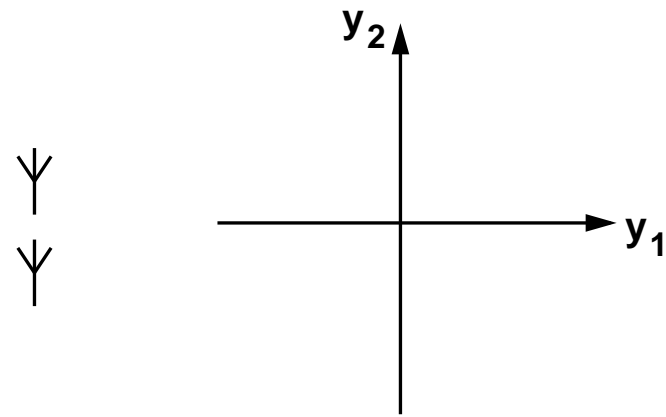

View #2: Fading is Good

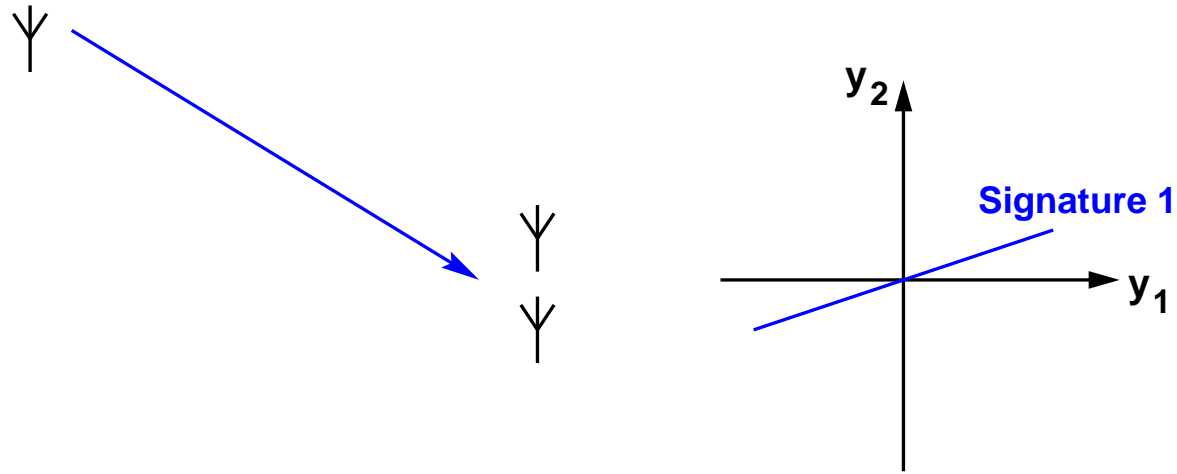

View #2: Fading is Good

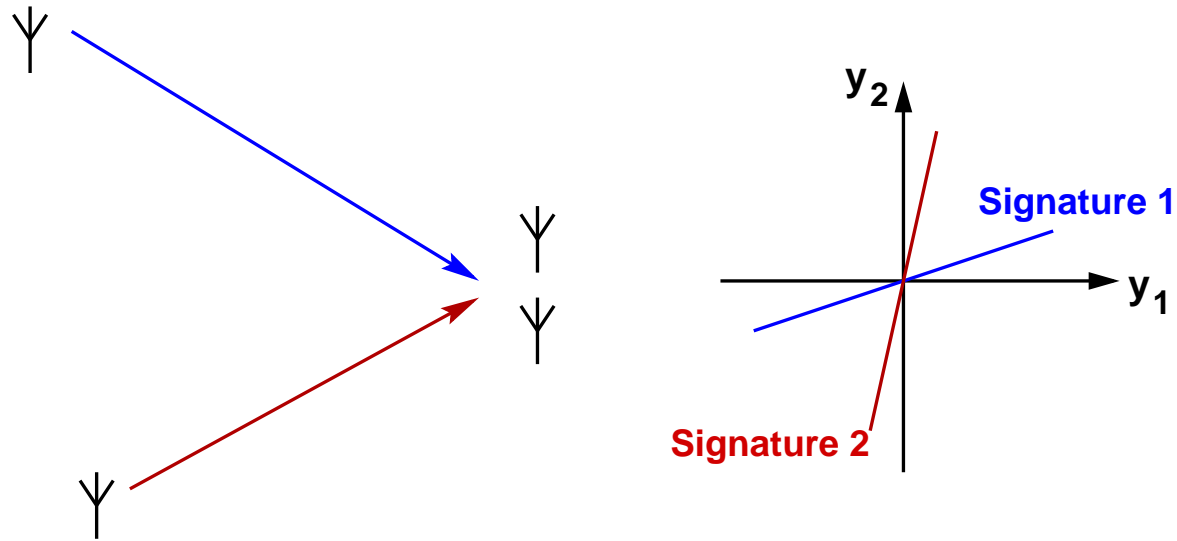

View #2: Fading is Good

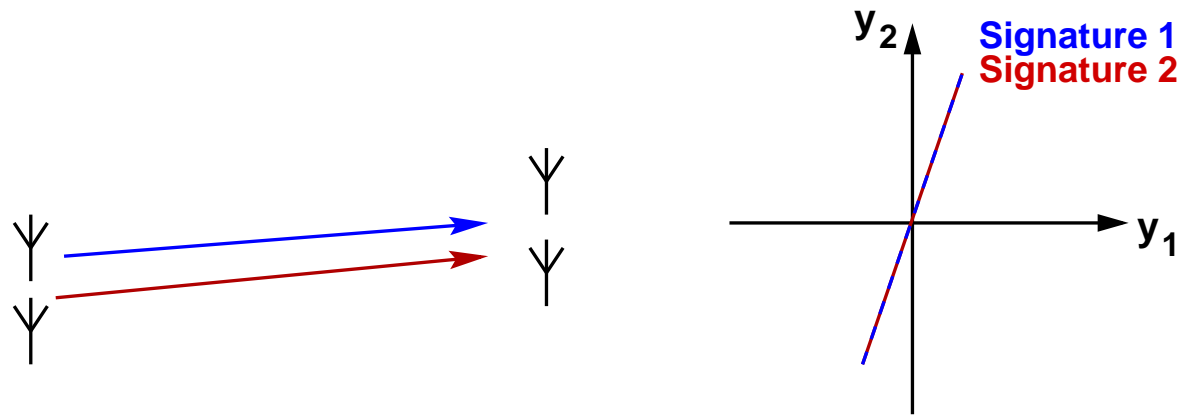

View #2: Fading is Good

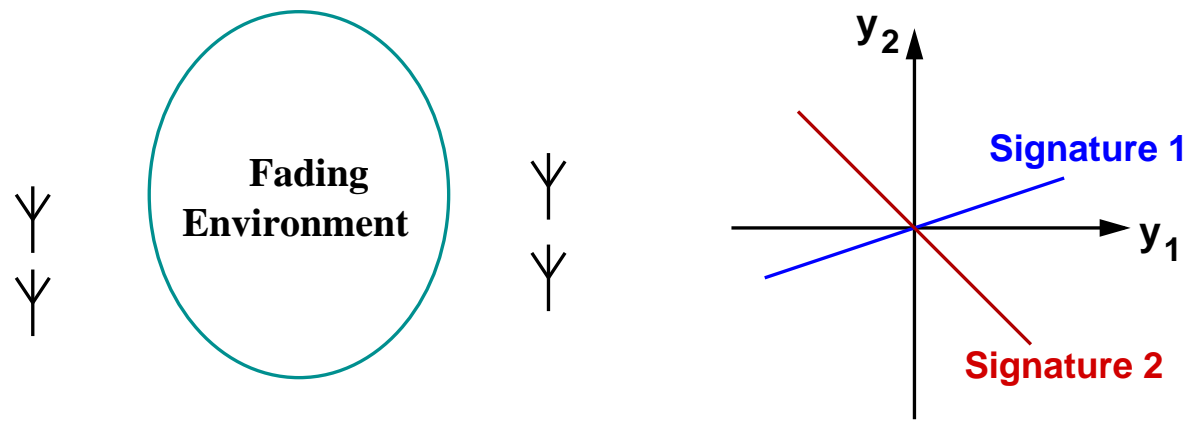

Multiple spatial channels created even when antennas are close together.

Freedom

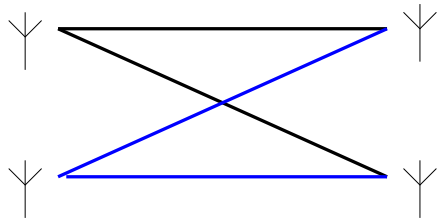

Another way to view a 2×2 system:

Freedom

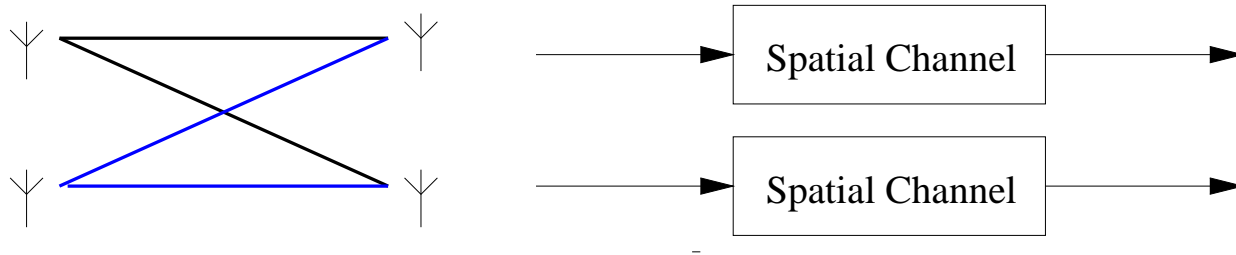

Another way to view a 2×2 system:

- Increases the **degrees of freedom** in the system.

Freedom

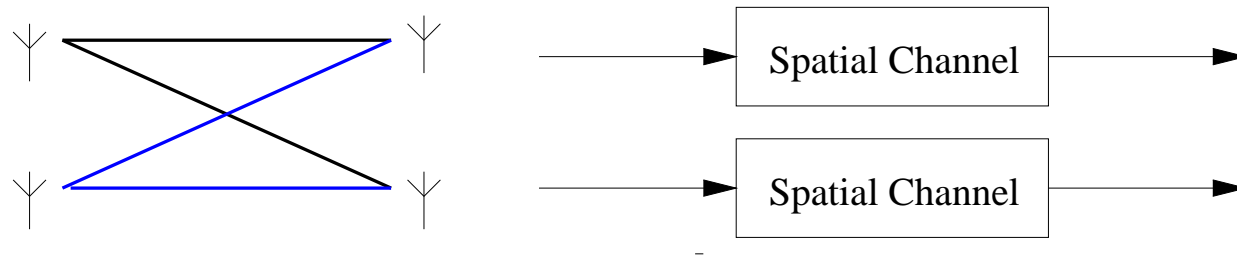

Another way to view a 2×2 system:

- Increases the **degrees of freedom** in the system.
- Multiple antennas provide parallel spatial channels: **spatial multiplexing**

Diversity vs. Multiplexing

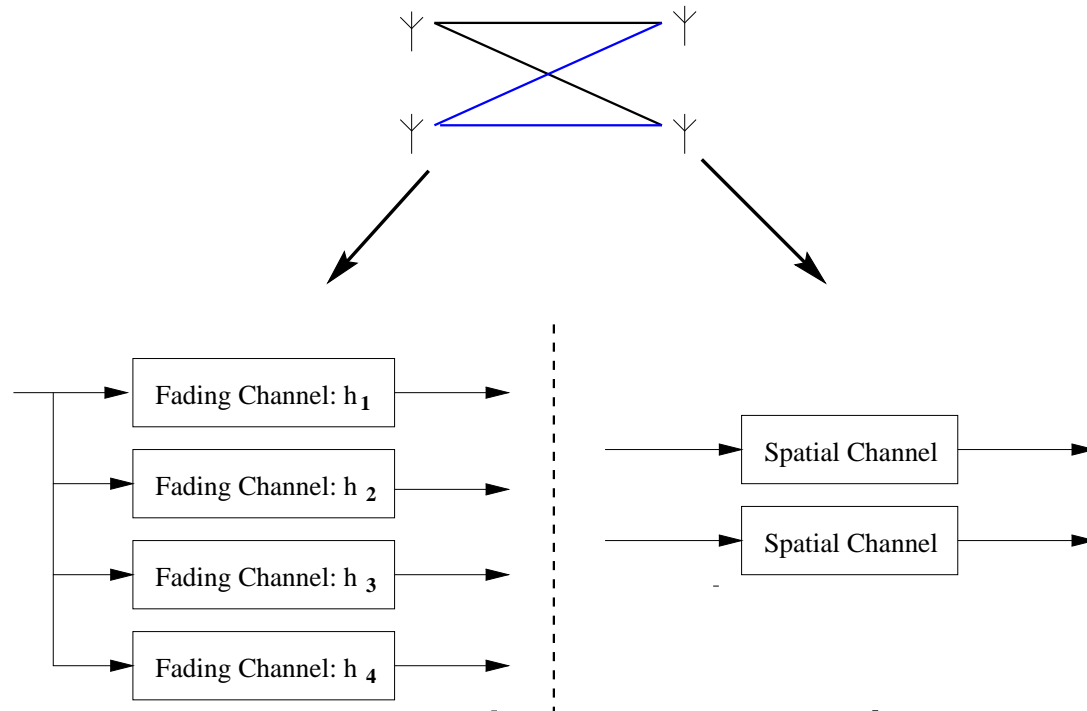

Multiple antenna channel provides two types of gains:

Diversity Gain vs. Spatial Multiplexing Gain

Diversity vs. Multiplexing

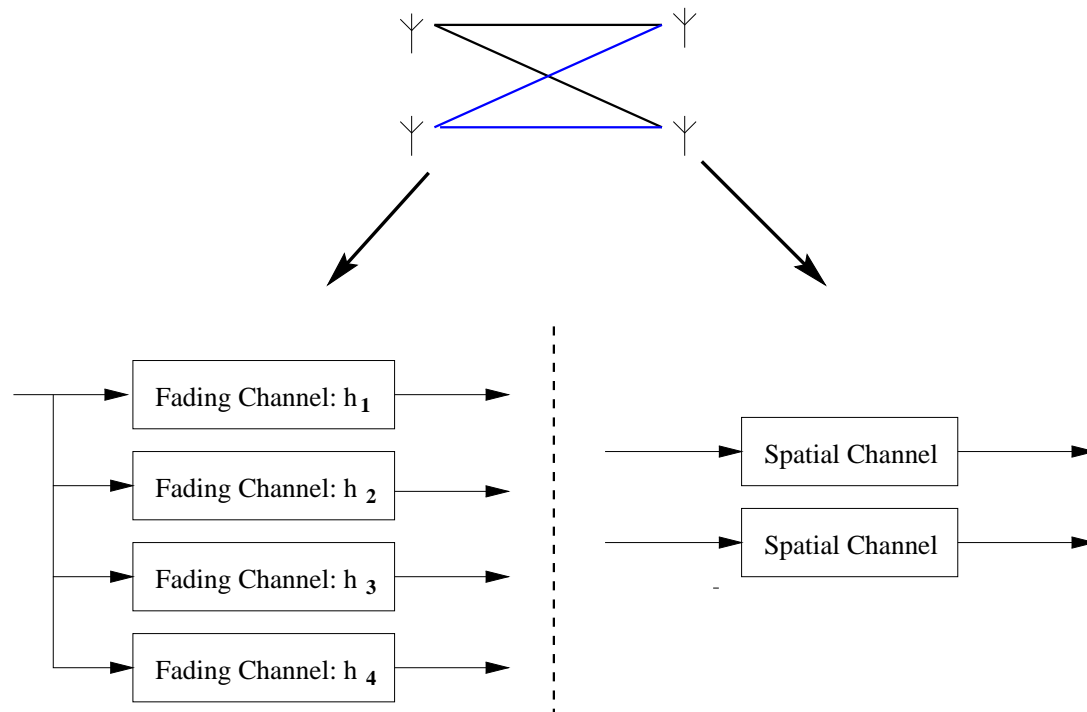

Multiple antenna channel provides two types of gains:

Diversity Gain vs. Spatial Multiplexing Gain

The research community has a split personality: existing schemes focus on one type of gain.

A Different Point of View

Both types of gains can be achieved **simultaneously** in a given multiple antenna channel

A Different Point of View

Both types of gains can be achieved **simultaneously** in a given multiple antenna channel, but there is a fundamental **tradeoff**.

Outline

- Precise problem formulation.
- A simple characterization of the optimal tradeoff.
- Sketch of proof.
- Tradeoff as a unified framework to compare different schemes.

Channel Model

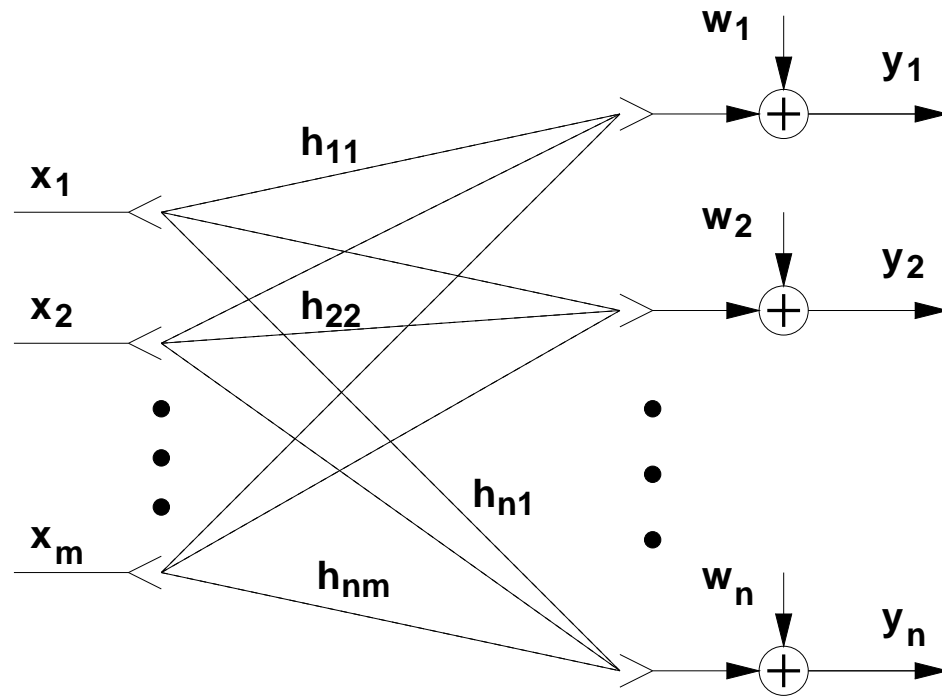

$$\mathbf{y}_t = \mathbf{H}_t \mathbf{x}_t + \mathbf{w}_t, \quad \mathbf{w}_t \sim \mathcal{CN}(0, 1)$$

- Rayleigh flat fading i.i.d. across antenna pairs ($h_{ij} \sim \mathcal{CN}(0, 1)$).
- SNR is the average signal-to-noise ratio at each receive antenna.

Coherent Block Fading Model

- Focus on codes over l symbols, where \mathbf{H} remains constant.
- \mathbf{H} is known to the receiver but not the transmitter.
- Assumption valid as long as

$$l \ll \text{coherence time} \times \text{coherence bandwidth.}$$

Space-Time Block Code

$$\mathbf{Y} = \mathbf{H}\mathbf{X} + \mathbf{W}$$

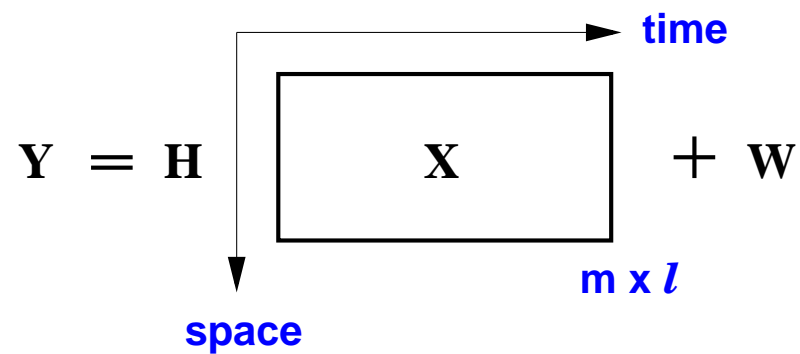

Focus on coding over a single block of length l .

How to Define Diversity Gain

Motivation: Binary Detection

$$\mathbf{y} = \mathbf{h}\mathbf{x} + \mathbf{w} \quad P_e \approx P(\|\mathbf{h}\| \text{ is small }) \propto \text{SNR}^{-1}$$

$$\left. \begin{array}{l} \mathbf{y}_1 = \mathbf{h}_1\mathbf{x} + \mathbf{w}_1 \\ \mathbf{y}_2 = \mathbf{h}_2\mathbf{x} + \mathbf{w}_2 \end{array} \right\} \quad P_e \approx P(\|\mathbf{h}_1\|, \|\mathbf{h}_2\| \text{ are both small}) \\ \propto \text{SNR}^{-2}$$

How to Define Diversity Gain

Motivation: Binary Detection

$$\mathbf{y} = \mathbf{h}\mathbf{x} + \mathbf{w} \quad P_e \approx P(\|\mathbf{h}\| \text{ is small }) \propto \text{SNR}^{-1}$$

$$\left. \begin{array}{l} \mathbf{y}_1 = \mathbf{h}_1\mathbf{x} + \mathbf{w}_1 \\ \mathbf{y}_2 = \mathbf{h}_2\mathbf{x} + \mathbf{w}_2 \end{array} \right\} \quad P_e \approx P(\|\mathbf{h}_1\|, \|\mathbf{h}_2\| \text{ are both small}) \\ \propto \text{SNR}^{-2}$$

General Definition

A space-time coding scheme achieves **diversity gain d** , if

$$P_e(\text{SNR}) \sim \text{SNR}^{-d}$$

How to Define Spatial Multiplexing Gain

Motivation: Channel capacity (Telatar '95, Foschini'96)

$$C(\text{SNR}) \approx \min\{m, n\} \log \text{SNR}(\text{bps}/\text{Hz})$$

$\min\{m, n\}$ **degrees of freedom** to communicate.

How to Define Spatial Multiplexing Gain

Motivation: Channel capacity (Telatar' 95, Foschini'96)

$$C(\text{SNR}) \approx \min\{m, n\} \log \text{SNR}(\text{bps}/\text{Hz})$$

$\min\{m, n\}$ **degrees of freedom** to communicate.

Definition A space-time coding scheme achieves **spatial multiplexing gain** r , if

$$R(\text{SNR}) = r \log \text{SNR}(\text{bps}/\text{Hz})$$

Fundamental Tradeoff

A space-time coding scheme achieves

Spatial Multiplexing Gain r : $R = r \log \text{SNR}$ (bps/Hz)

and

Diversity Gain d : $P_e \approx \text{SNR}^{-d}$

Fundamental Tradeoff

A space-time coding scheme achieves

Spatial Multiplexing Gain r : $R = r \log \text{SNR}$ (bps/Hz)

and

Diversity Gain d : $P_e \approx \text{SNR}^{-d}$

Fundamental tradeoff: for any r , the maximum diversity gain achievable: $d^*(r)$.

$$r \rightarrow d^*(r)$$

Fundamental Tradeoff

A space-time coding scheme achieves

$$\text{Spatial Multiplexing Gain } r \quad : \quad R = r \log \text{SNR} \quad (\text{bps/Hz})$$

and

$$\text{Diversity Gain } d \quad : \quad P_e \approx \text{SNR}^{-d}$$

Fundamental tradeoff: for any r , the maximum diversity gain achievable: $d^*(r)$.

$$r \rightarrow d^*(r)$$

A tradeoff between data rate and error probability.

Outline

- Precise problem formulation.
- A simple characterization of the optimal tradeoff.
- Sketch of proof.
- Tradeoff as a unified framework to compare different schemes.

Main Result: Optimal Tradeoff

m : # of Tx. Ant.

n : # of Rx. Ant.

l : block length

$$l \geq m + n - 1$$

d : diversity gain

$$P_e \approx \text{SNR}^{-d}$$

r : multiplexing gain

$$R = r \log \text{SNR}$$

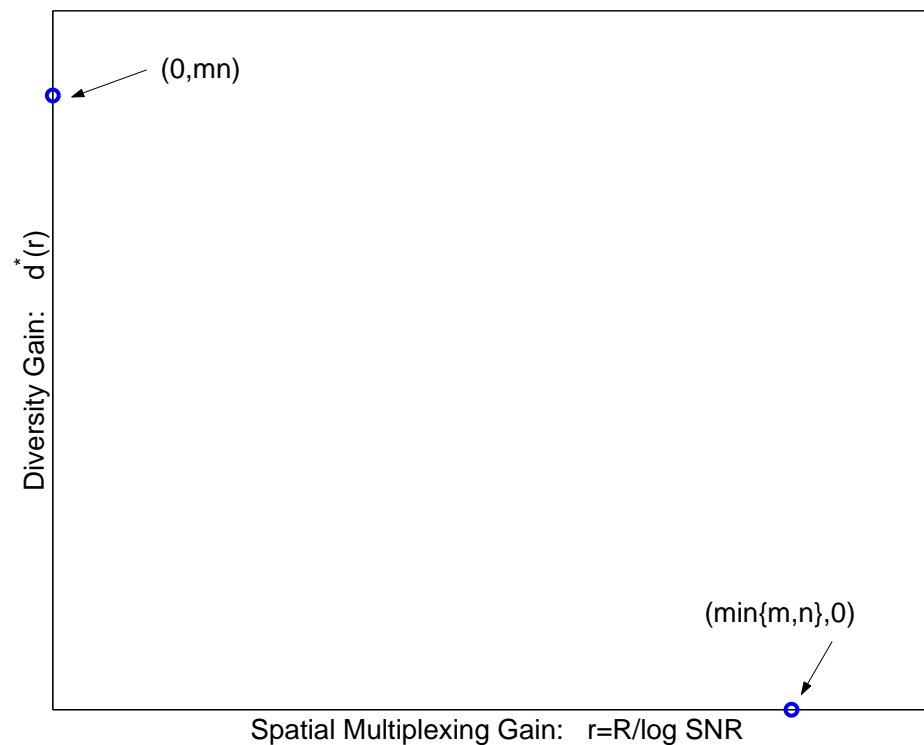

Recall: 2×2 system

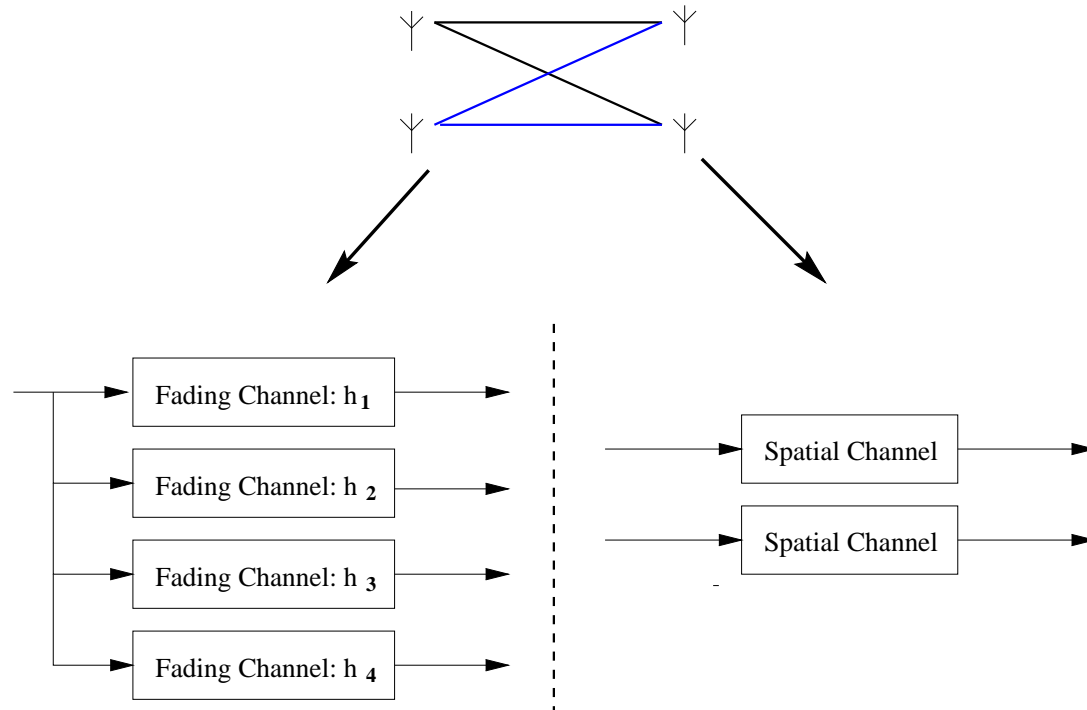

Main Result: Optimal Tradeoff

m : # of Tx. Ant.

n : # of Rx. Ant.

l : block length

$$l \geq m + n - 1$$

d : diversity gain

$$P_e \approx \text{SNR}^{-d}$$

r : multiplexing gain

$$R = r \log \text{SNR}$$

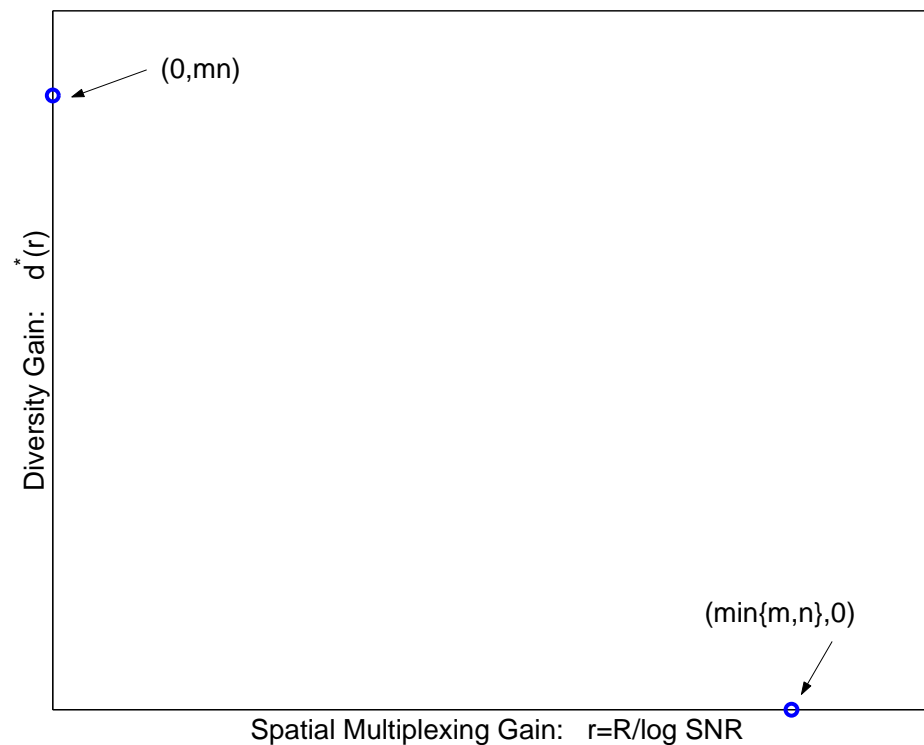

Main Result: Optimal Tradeoff

m : # of Tx. Ant.

n : # of Rx. Ant.

l : block length

$$l \geq m + n - 1$$

d : diversity gain

$$P_e \approx \text{SNR}^{-d}$$

r : multiplexing gain

$$R = r \log \text{SNR}$$

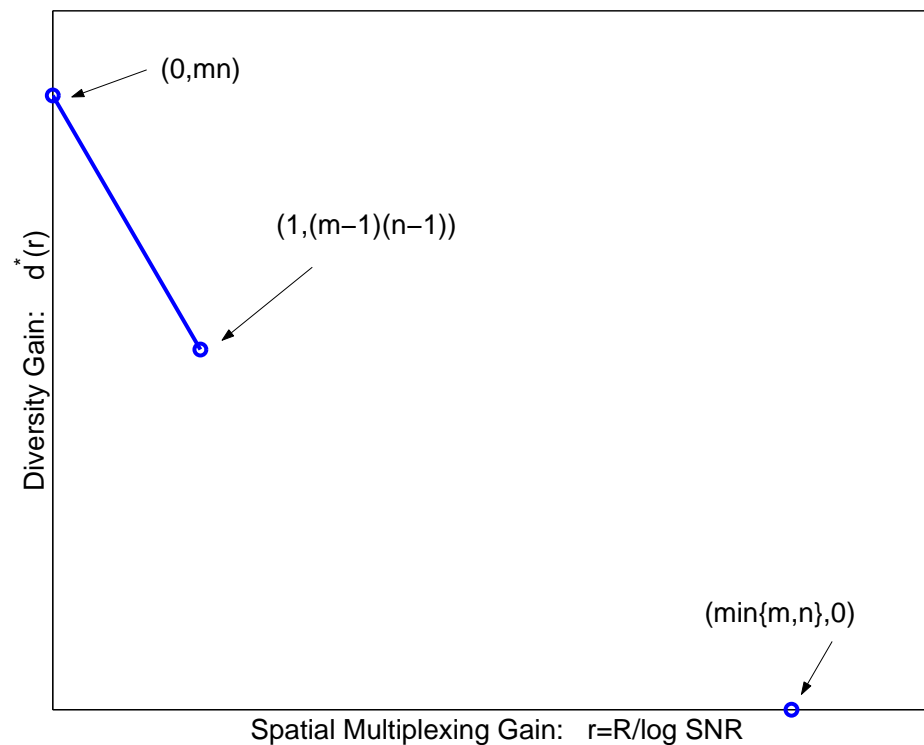

Main Result: Optimal Tradeoff

m : # of Tx. Ant.

n : # of Rx. Ant.

l : block length

$$l \geq m + n - 1$$

d : diversity gain

$$P_e \approx \text{SNR}^{-d}$$

r : multiplexing gain

$$R = r \log \text{SNR}$$

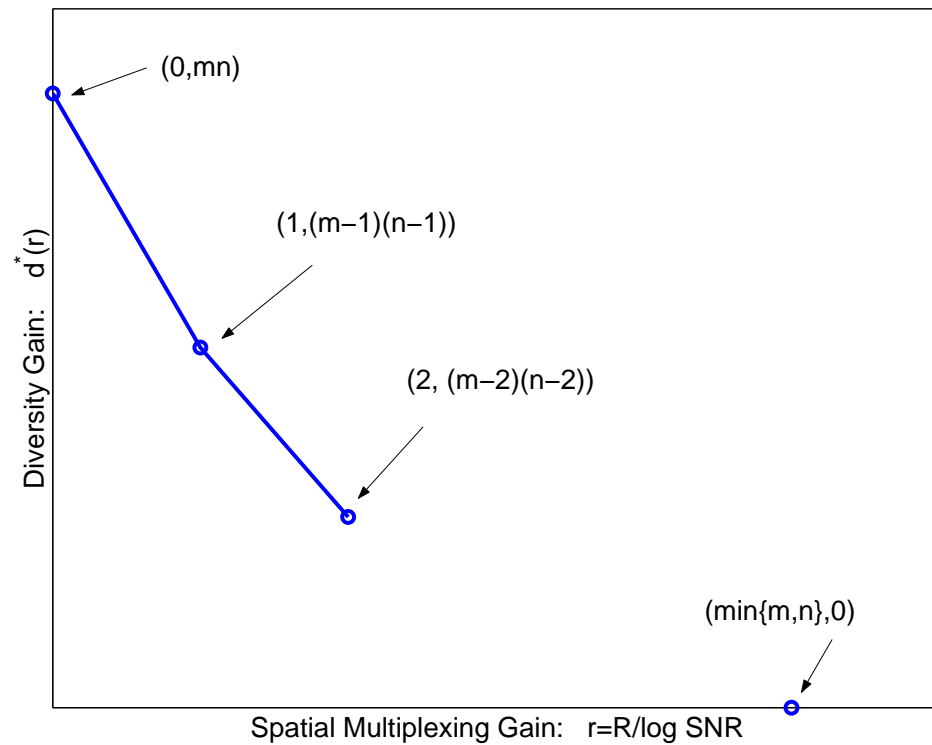

Main Result: Optimal Tradeoff

m : # of Tx. Ant.

n : # of Rx. Ant.

l : block length

$$l \geq m + n - 1$$

d : diversity gain

$$P_e \approx \text{SNR}^{-d}$$

r : multiplexing gain

$$R = r \log \text{SNR}$$

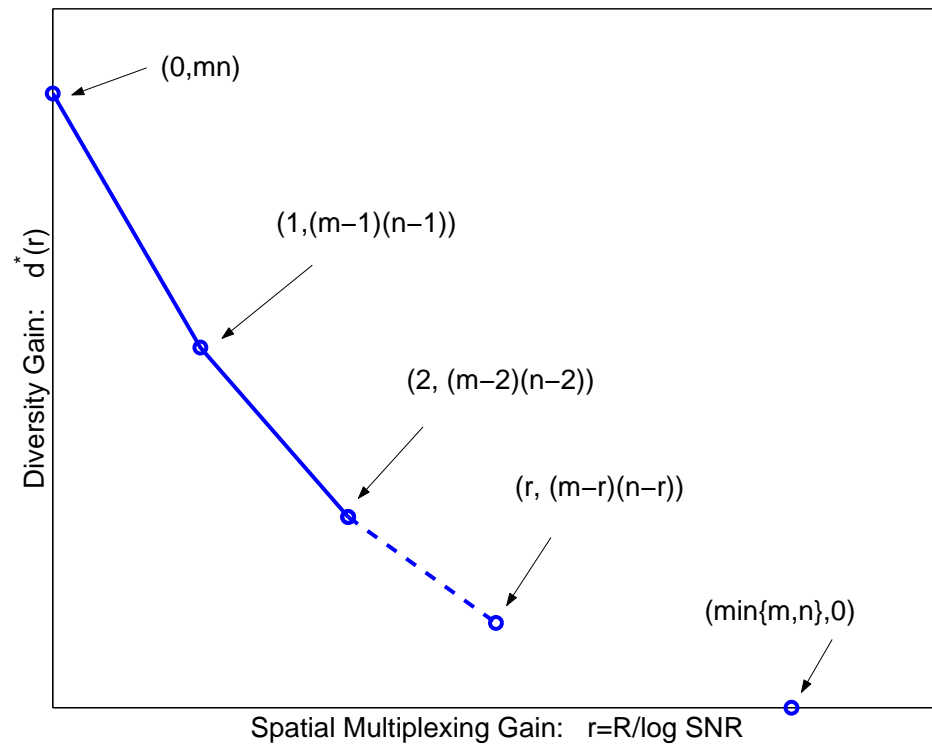

Main Result: Optimal Tradeoff

m : # of Tx. Ant.

n : # of Rx. Ant.

l : block length

$$l \geq m + n - 1$$

d : diversity gain

$$P_e \approx \text{SNR}^{-d}$$

r : multiplexing gain

$$R = r \log \text{SNR}$$

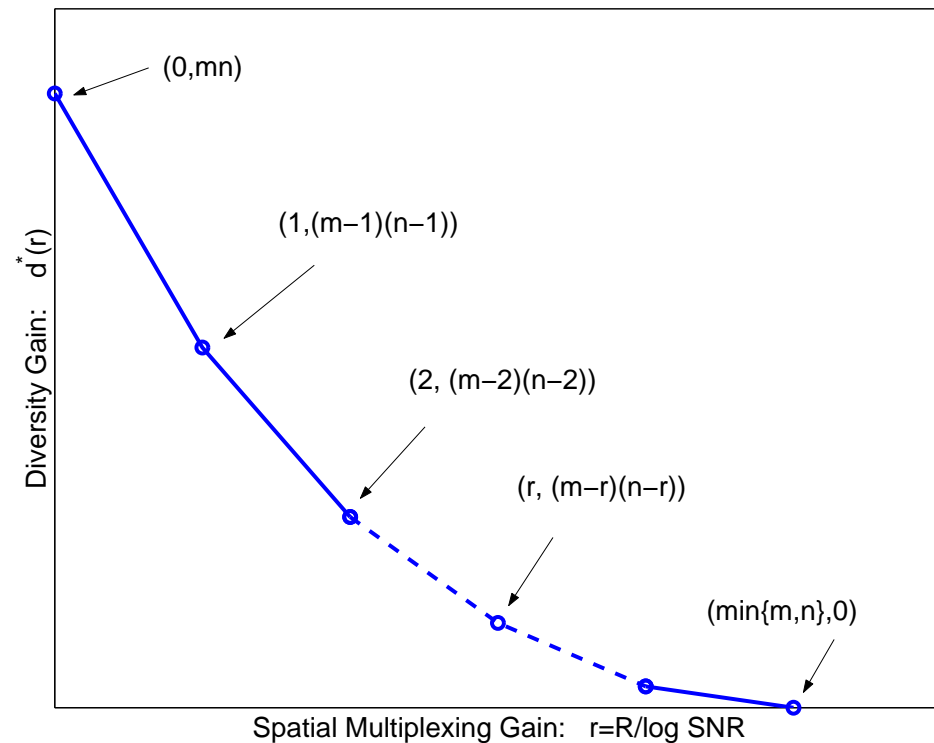

For integer r , it is *as though* r transmit and r receive antennas were dedicated for multiplexing and the rest provide diversity.

Main Result: Optimal Tradeoff

m : # of Tx. Ant.

n : # of Rx. Ant.

l : block length

$$l \geq m + n - 1$$

d : diversity gain

$$P_e \approx \text{SNR}^{-d}$$

r : multiplexing gain

$$R = r \log \text{SNR}$$

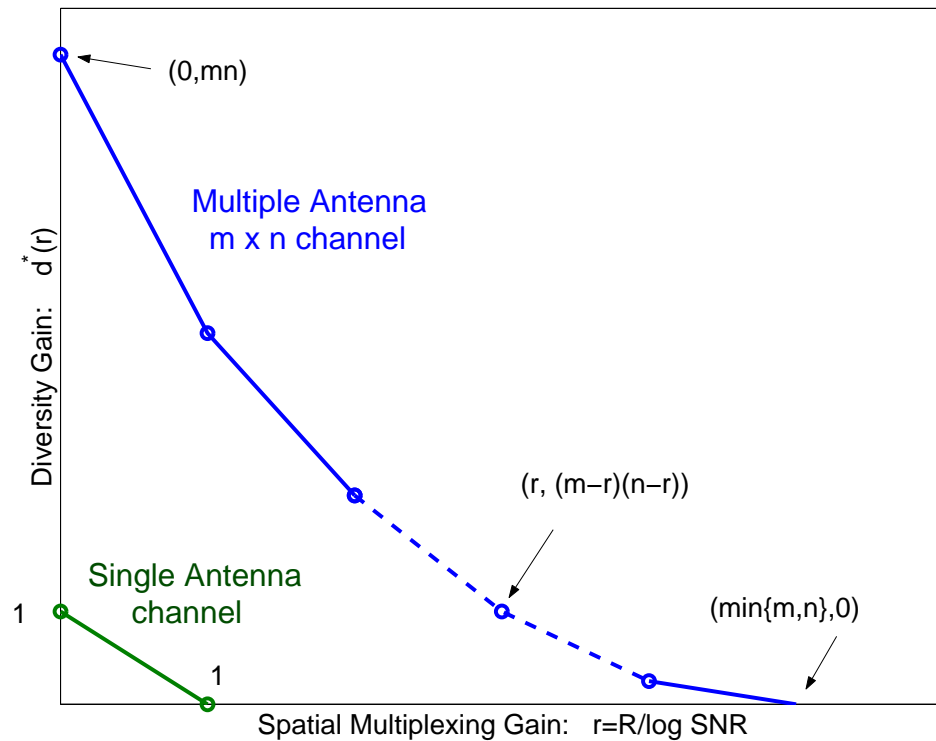

For integer r , it is *as though* r transmit and r receive antennas were dedicated for multiplexing and the rest provide diversity.

Main Result: Optimal Tradeoff

Theorem: In a channel with m transmit and n receive antennas, for any space-time coding scheme with block length $l \geq m + n - 1$ that achieves spatial multiplexing gain of r , the error probability is lower bounded by:

$$\lim_{\text{SNR} \rightarrow \infty} \frac{\log P_e(\text{SNR})}{\log \text{SNR}} \geq -d^*(r)$$

Furthermore, there exists a coding scheme that achieves this lower bound with equality.

A Conceptual Picture

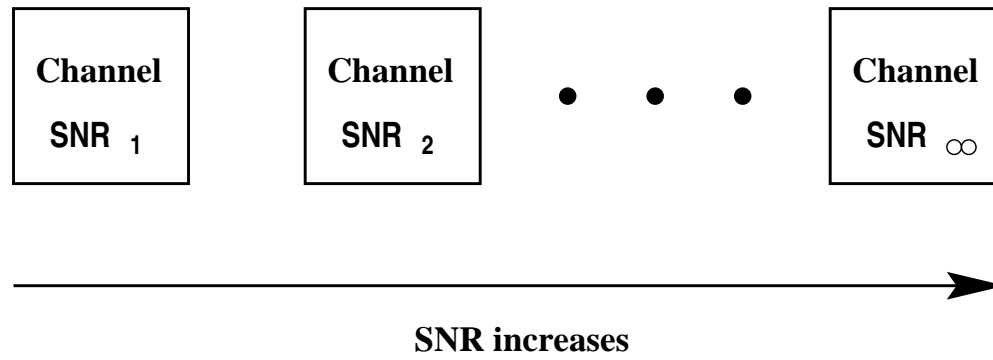

A Conceptual Picture

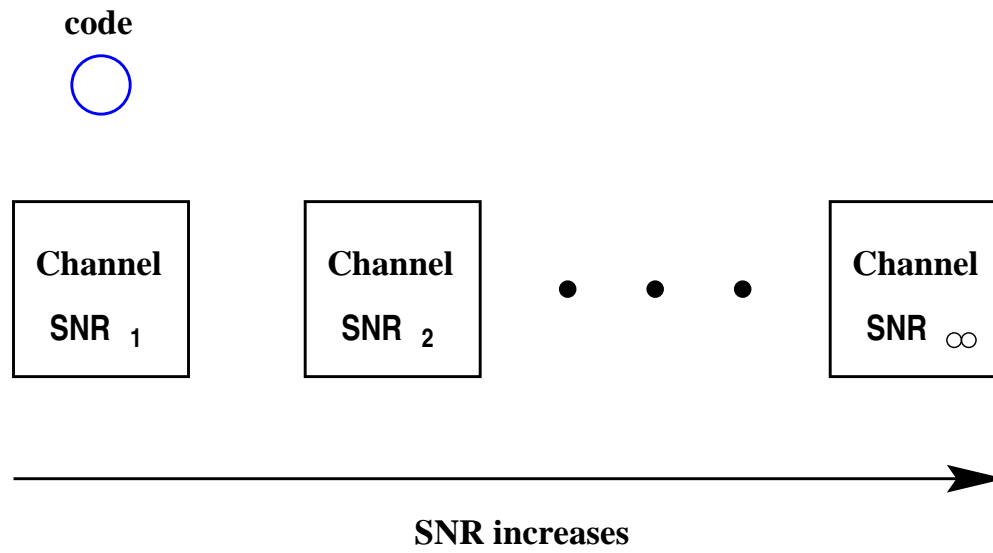

A Conceptual Picture

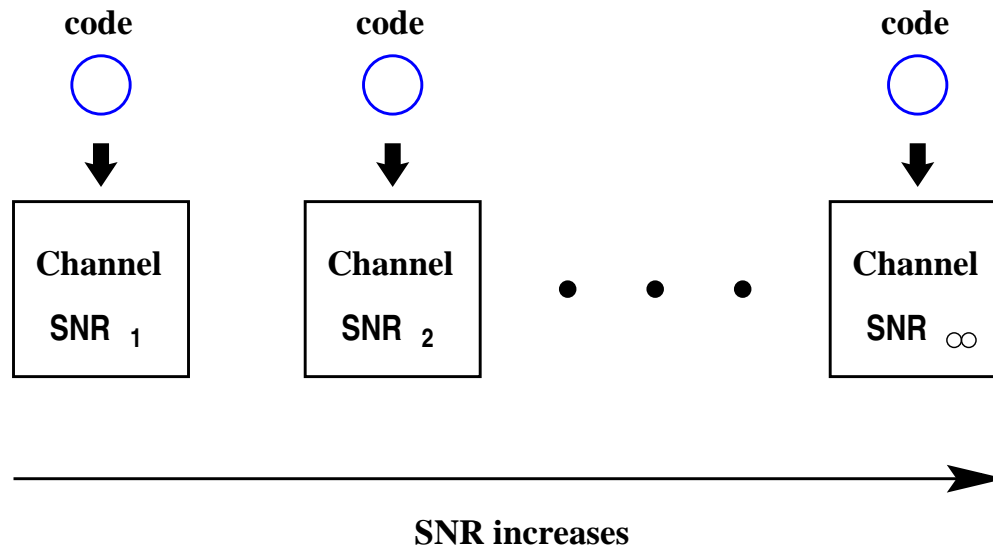

A Conceptual Picture

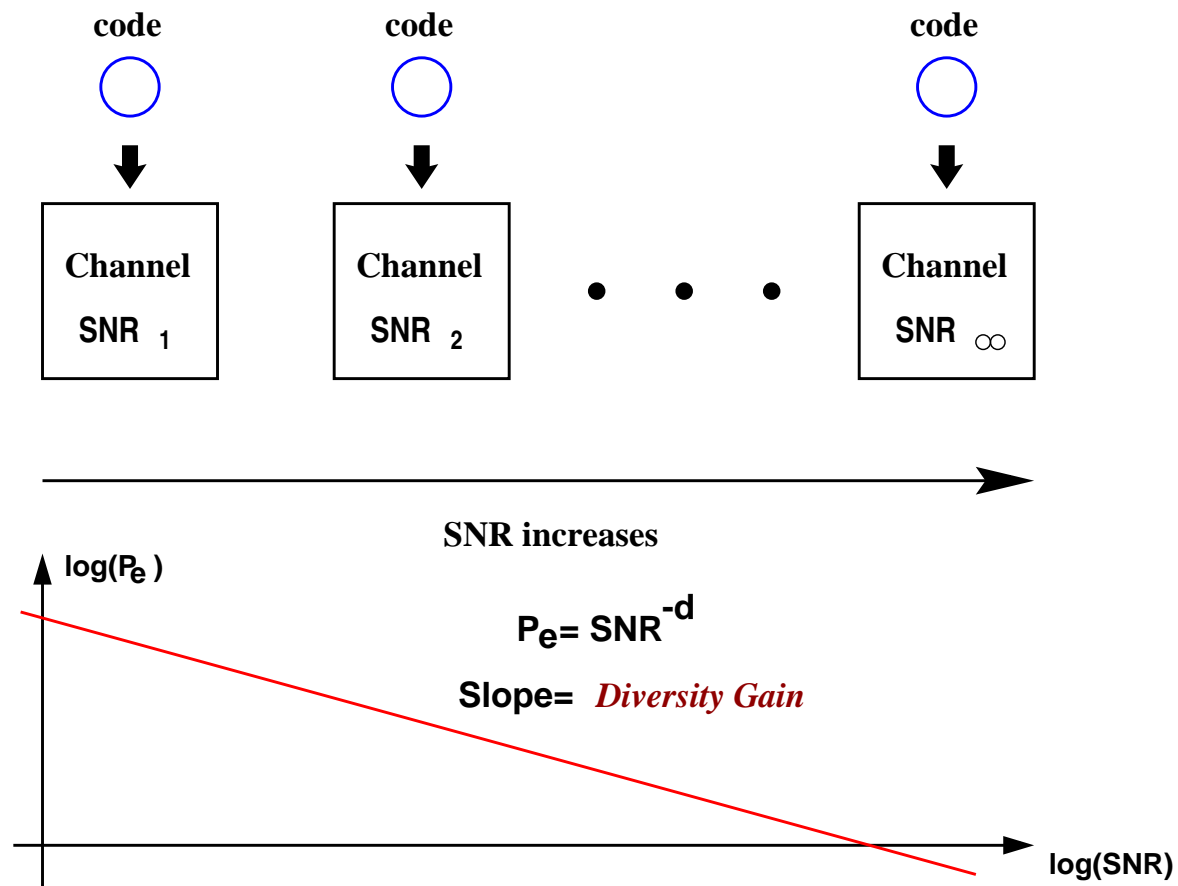

A Conceptual Picture

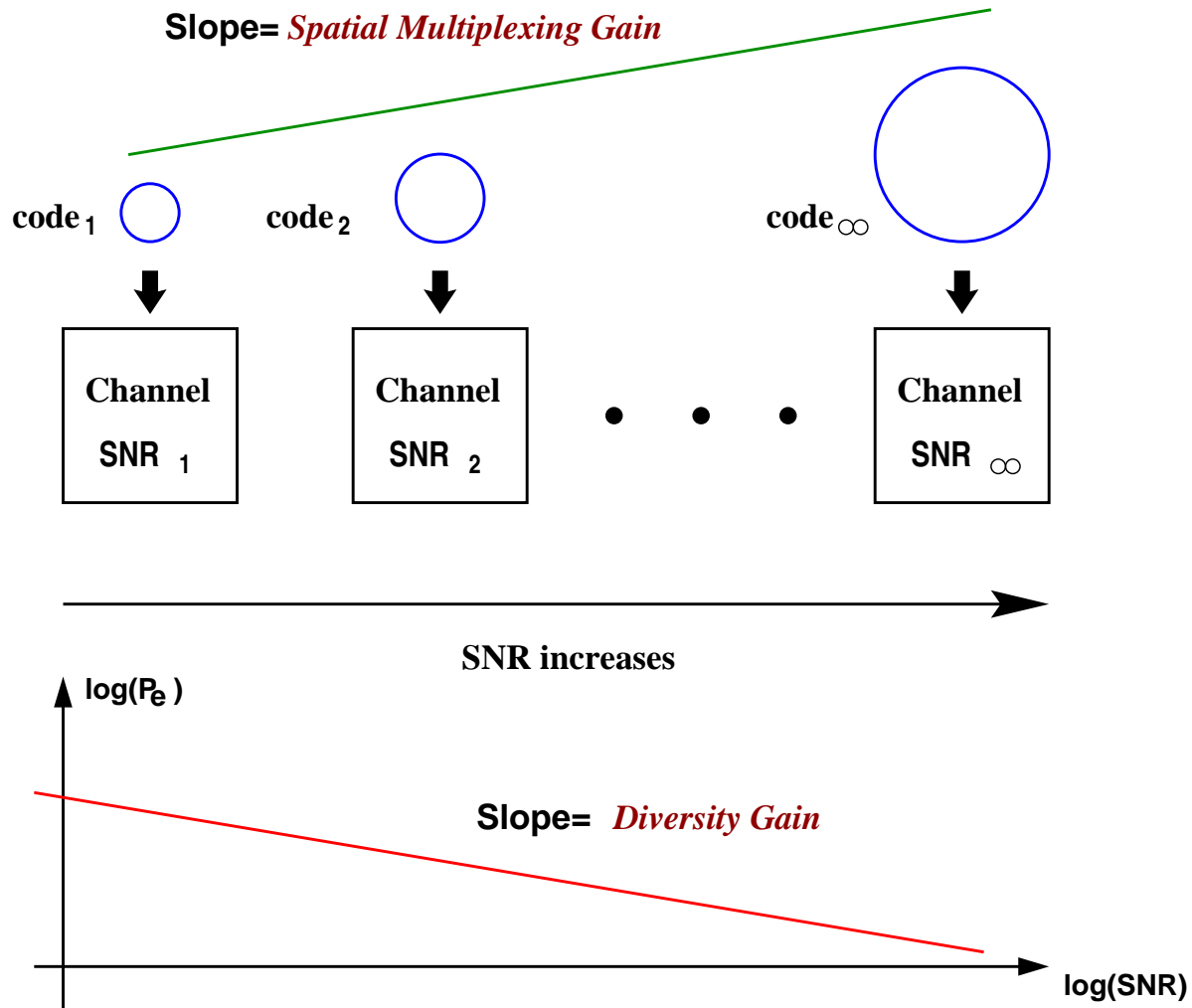

What do I get by adding one more antenna?

Adding More Antennas

m : # of Tx. Ant.

n : # of Rx. Ant.

l : block length

$l \geq m + n - 1$

d : diversity gain

r : multiplexing gain

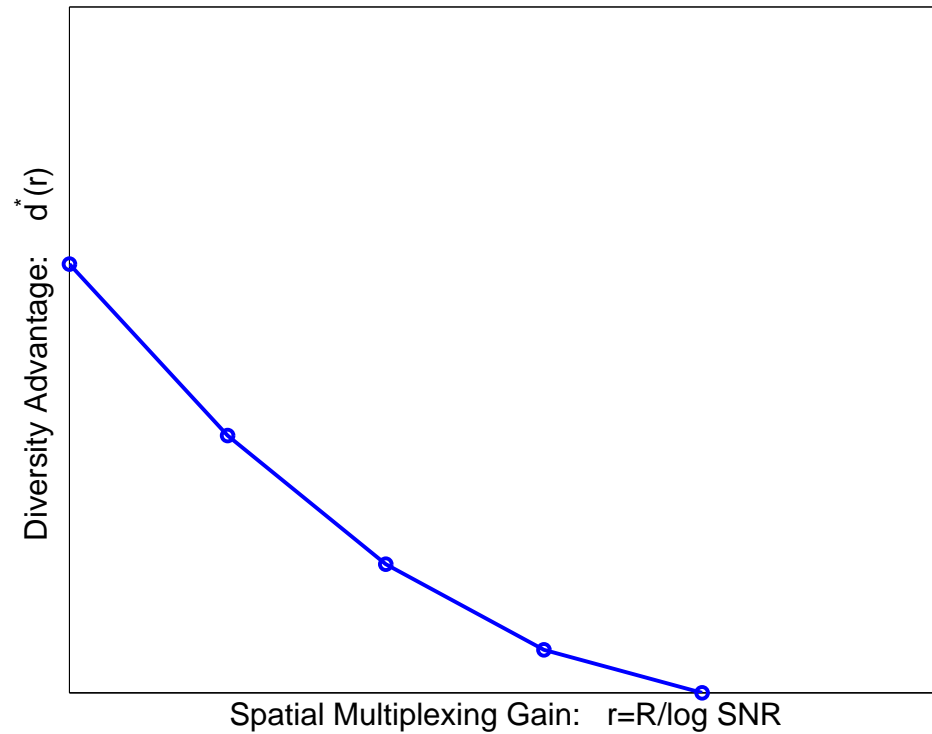

Adding More Antennas

m : # of Tx. Ant.

n : # of Rx. Ant.

l : block length

$l \geq m + n - 1$

d : diversity gain

r : multiplexing gain

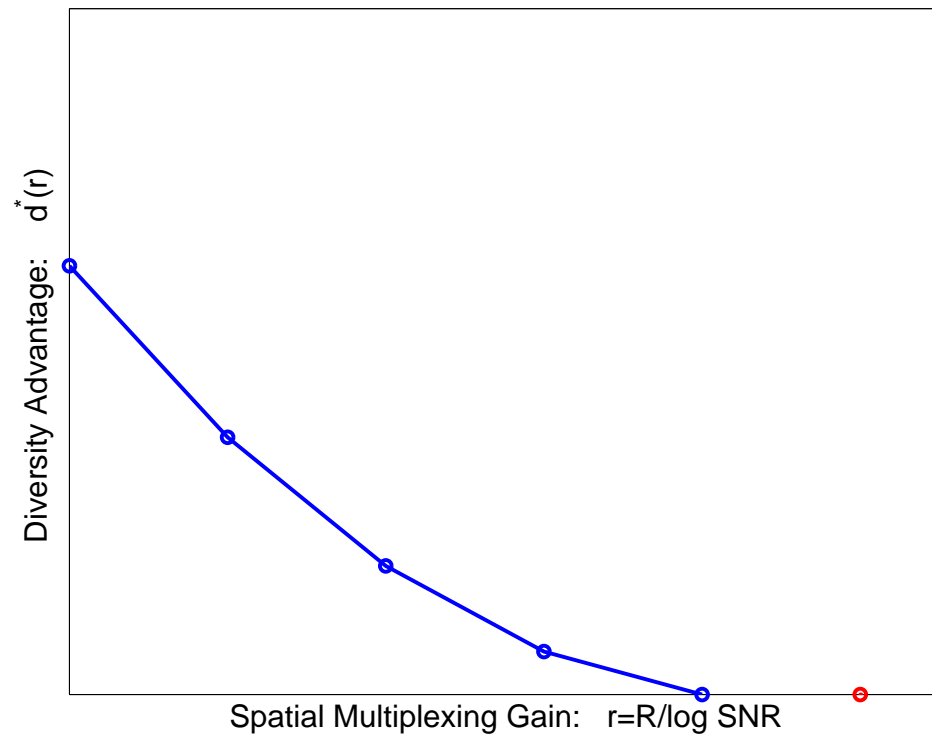

- **Capacity result** : increasing $\min\{m, n\}$ by 1 adds 1 more degree of freedom.

Adding More Antennas

m : # of Tx. Ant.

n : # of Rx. Ant.

l : block length

$l \geq m + n - 1$

d : diversity gain

r : multiplexing gain

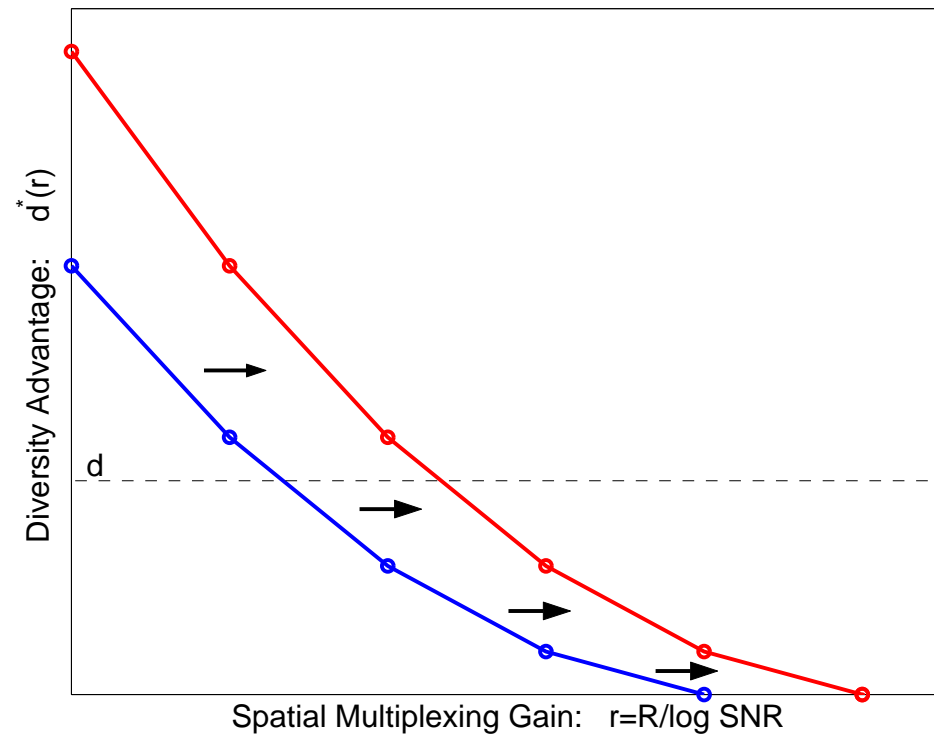

- **Capacity result:** increasing $\min\{m, n\}$ by 1 adds 1 more degree of freedom.
- **Tradeoff curve:** increasing both m and n by 1 yields multiplexing gain +1 for any diversity requirement d .

To Fade or Not to Fade?

Fading

LOS Non-Fading AWGN Channel

$$\mathbf{y} = \mathbf{x} + \mathbf{w}$$

Fading Channel

$$\mathbf{y} = \mathbf{h}\mathbf{x} + \mathbf{w}$$

Fading

LOS Non-Fading AWGN Channel

$$\mathbf{y} = \mathbf{x} + \mathbf{w}$$

Error occurs when **noise is large**,
with probability

$$P_e \approx \exp(-\text{SNR})$$

Fading Channel

$$\mathbf{y} = \mathbf{h}\mathbf{x} + \mathbf{w}$$

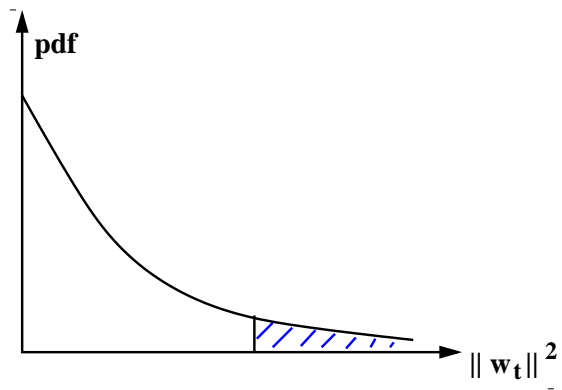

Fading

LOS Non-Fading AWGN Channel

$$\mathbf{y} = \mathbf{x} + \mathbf{w}$$

Error occurs when **noise is large**, with probability

$$P_e \approx \exp(-\text{SNR})$$

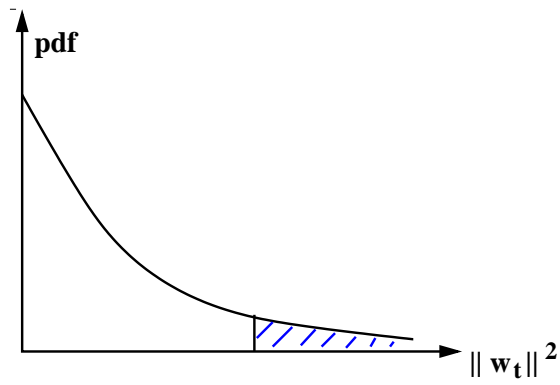

Fading Channel

$$\mathbf{y} = \mathbf{h}\mathbf{x} + \mathbf{w}$$

Error occurs when the channel is in **deep fade**, with probability

$$P_e \approx \text{SNR}^{-1}$$

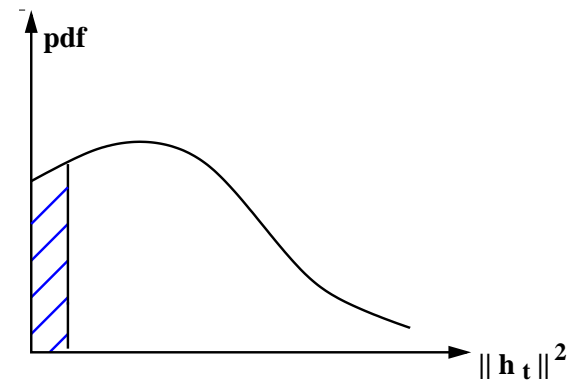

Fading

LOS Non-Fading AWGN Channel

$$\mathbf{y} = \mathbf{x} + \mathbf{w}$$

Error occurs when **noise is large**, with probability

$$P_e \approx \exp(-\text{SNR})$$

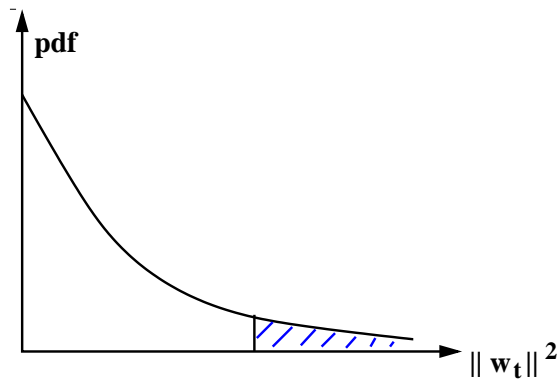

Fading Channel

$$\mathbf{y} = \mathbf{h}\mathbf{x} + \mathbf{w}$$

Error occurs when the channel is in **deep fade**, with probability

$$P_e \approx \text{SNR}^{-1}$$

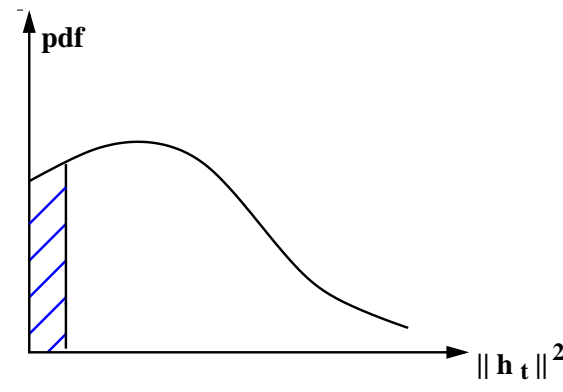

Deep fades are major cause of error

Fading

LOS Non-Fading AWGN Channel

$$\mathbf{y} = \mathbf{x} + \mathbf{w}$$

Error occurs when **noise is large**, with probability

$$P_e \approx \exp(-\text{SNR})$$

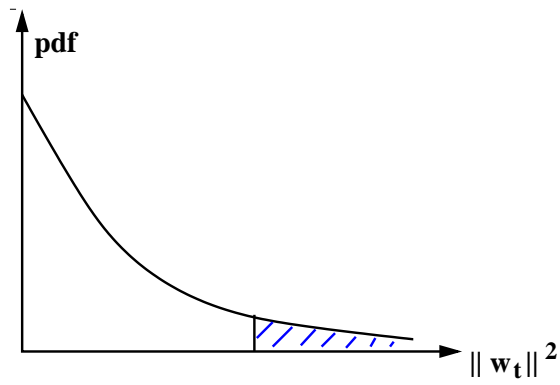

Infinite diversity.

Deep fades are major cause of error

Fading Channel

$$\mathbf{y} = \mathbf{h}\mathbf{x} + \mathbf{w}$$

Error occurs when the channel is in **deep fade**, with probability

$$P_e \approx \text{SNR}^{-1}$$

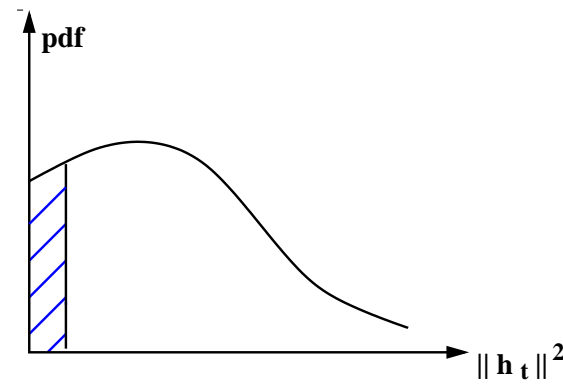

Need to increase diversity

Line-of-Sight vs Fading Channel

m : # of Tx. Ant.

n : # of Rx. Ant.

d : Diversity gain

r : Multiplexing Gain

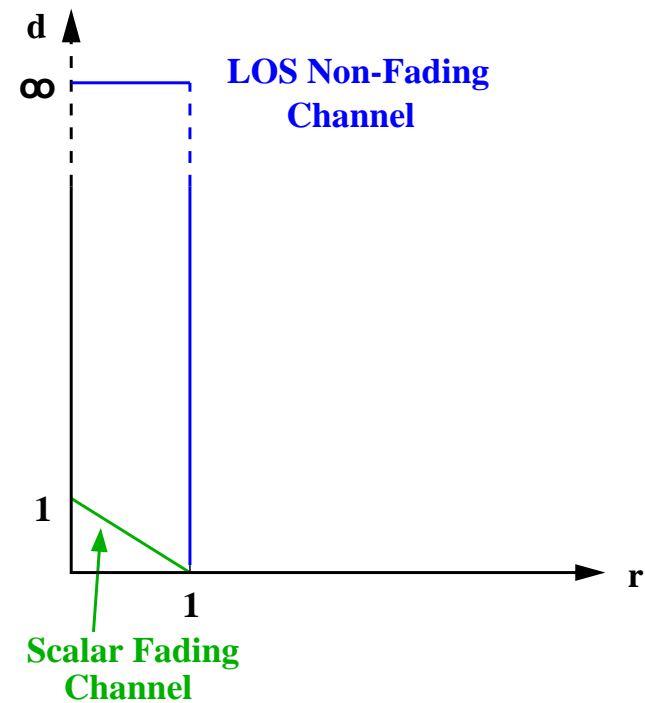

- In a scalar 1×1 system, line-of-sight AWGN is better.

Line-of-Sight vs Fading Channel

m : # of Tx. Ant.

n : # of Rx. Ant.

d : Diversity gain

r : Multiplexing Gain

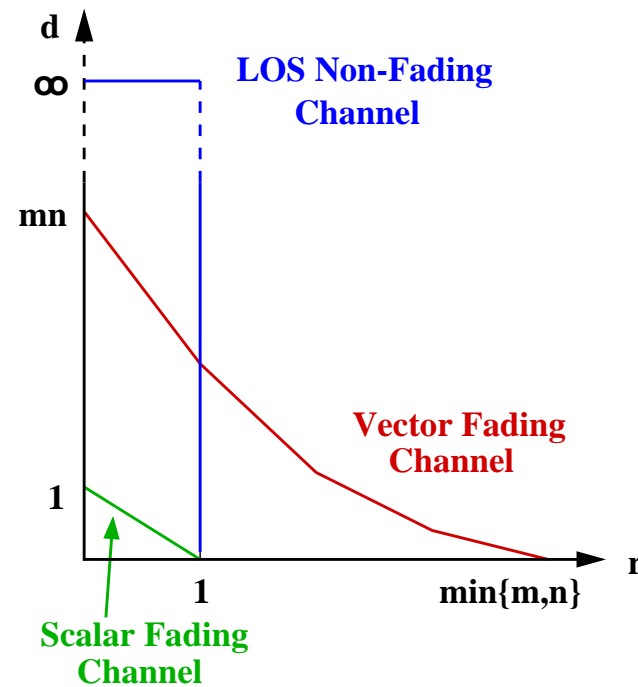

- In a scalar 1×1 system, line-of-sight AWGN is better.
- In a vector $m \times n$ system, fading is exploited as a source of randomness to provide multiple degrees of freedom.

Line-of-Sight vs Fading Channel

m : # of Tx. Ant.

n : # of Rx. Ant.

d : Diversity gain

r : Multiplexing Gain

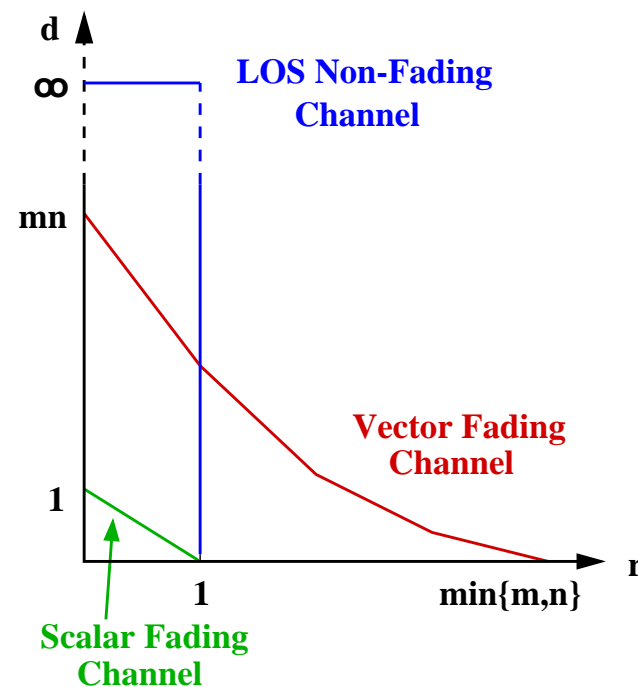

- In a scalar 1×1 system, line-of-sight AWGN is better.
- In a vector $m \times n$ system, fading is exploited as a source of randomness to provide multiple degrees of freedom.
- Whether fading is good or bad depends on where you operate.

Outline

- Precise problem formulation.
- A simple characterization of the optimal tradeoff.
- Sketch of proof.
- Tradeoff as a unified framework to compare different schemes.

Converse: Outage Bound

- Outage formulation for quasi-static scenarios. (Ozarow et al 94, Telatar 95)
- Look at the mutual information per symbol $I(Q, \mathbf{H})$ as a function of the input distribution and channel realization.

Converse: Outage Bound

- Outage formulation for quasi-static scenarios. (Ozarow et al 94, Telatar 95)
- Look at the mutual information per symbol $I(Q, \mathbf{H})$ as a function of the input distribution and channel realization.
- Error probability for finite block length l is asymptotically lower bounded by the outage probability:

$$\inf_Q P_{\mathbf{H}} [I(Q, \mathbf{H}) < R].$$

Converse: Outage Bound

- Outage formulation for quasi-static scenarios. (Ozarow et al 94, Telatar 95)
- Look at the mutual information per symbol $I(Q, \mathbf{H})$ as a function of the input distribution and channel realization.
- Error probability for finite block length l is asymptotically lower bounded by the outage probability:

$$\inf_Q P_{\mathbf{H}} [I(Q, \mathbf{H}) < R].$$

- At high SNR, i.i.d. Gaussian input Q^* is asymptotically optimal, and

$$I(Q^*, \mathbf{H}) = \log \det [I + \text{SNR} \mathbf{H} \mathbf{H}^*].$$

Outage Analysis

$$P(\text{Outage}) = P\{I(\mathbf{H}) = \log \det[I + \text{SNR}\mathbf{H}\mathbf{H}^\dagger] < R\}$$

- In scalar 1×1 channel, outage occurs when the channel gain $\|\mathbf{h}\|^2$ is small.

Outage Analysis

$$P(\text{Outage}) = P\{I(\mathbf{H}) = \log \det[I + \text{SNR}\mathbf{H}\mathbf{H}^\dagger] < R\}$$

- In scalar 1×1 channel, outage occurs when the channel gain $\|\mathbf{h}\|^2$ is small.
- In general $m \times n$ channel, outage occurs when some or all of the singular values of \mathbf{H} are small. There are many ways for this to happen.

Outage Analysis

$$P(\text{Outage}) = P\{I(\mathbf{H}) = \log \det[I + \text{SNR}\mathbf{H}\mathbf{H}^\dagger] < R\}$$

- In scalar 1×1 channel, outage occurs when the channel gain $\|\mathbf{h}\|^2$ is small.
- In general $m \times n$ channel, outage occurs when some or all of the singular values of \mathbf{H} are small. There are many ways for this to happen.
- Let \mathbf{v} = vector of singular values of \mathbf{H} :

Laplace Principle:

$$P(\text{Outage}) \approx \min_{\mathbf{v} \in \text{Out}} \text{SNR}^{-f(\mathbf{v})}$$

Geometric Picture (integer r)

Scalar Channel

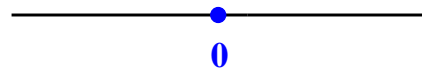

Geometric Picture (integer r)

Scalar Channel

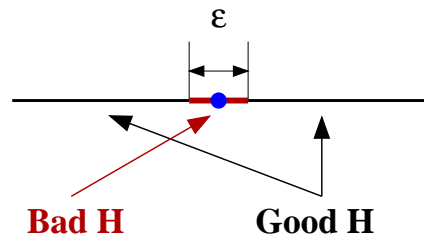

Geometric Picture (integer r)

Scalar Channel

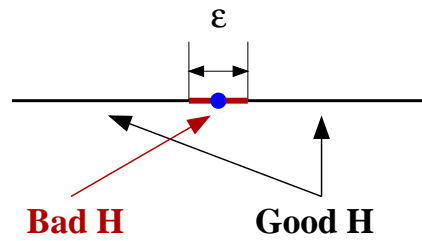

Vector Channel

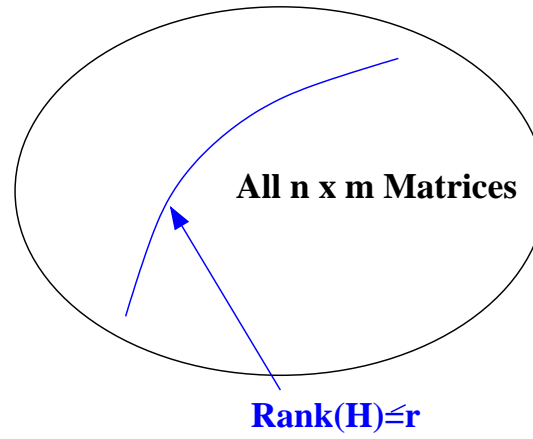

Geometric Picture (integer r)

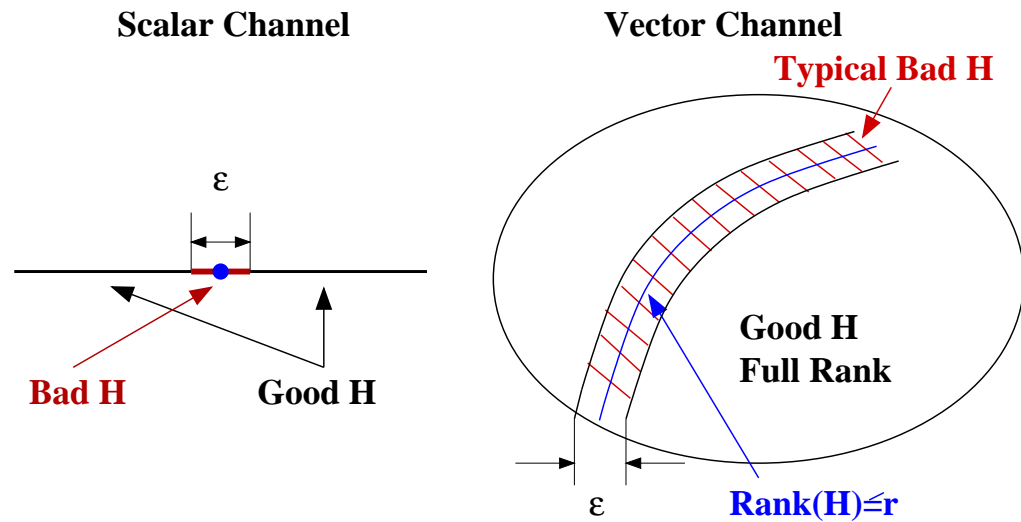

Result: At rate $R = r \log \text{SNR}$, for r integer, outage occurs typically when \mathbf{H} is close to the set $\{\mathbf{H} : \text{rank}(\mathbf{H}) \leq r\}$,

Geometric Picture (integer r)

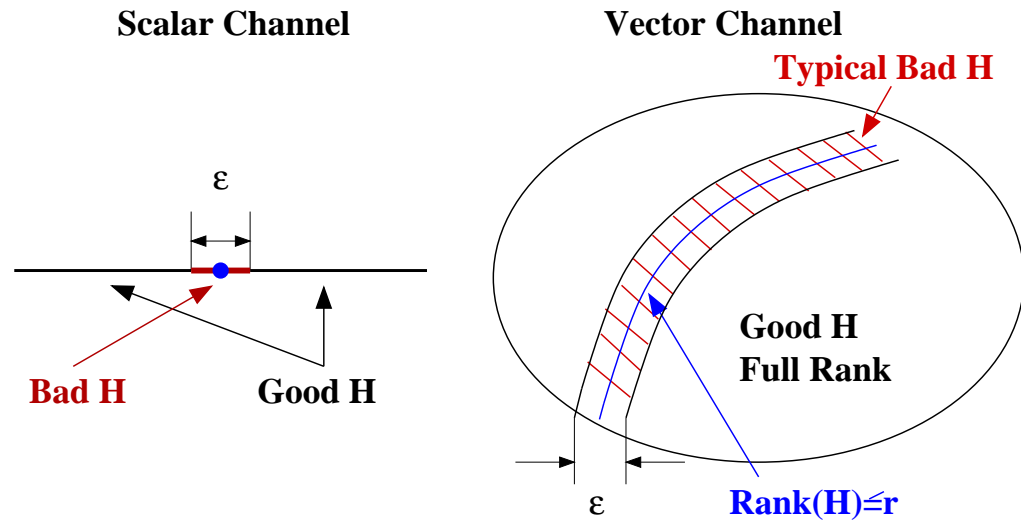

Result: At rate $R = r \log \text{SNR}$, for r integer, outage occurs typically when \mathbf{H} is close to the set $\{\mathbf{H} : \text{rank}(\mathbf{H}) \leq r\}$, with $\epsilon^2 = \text{SNR}^{-1}$.

Geometric Picture (integer r)

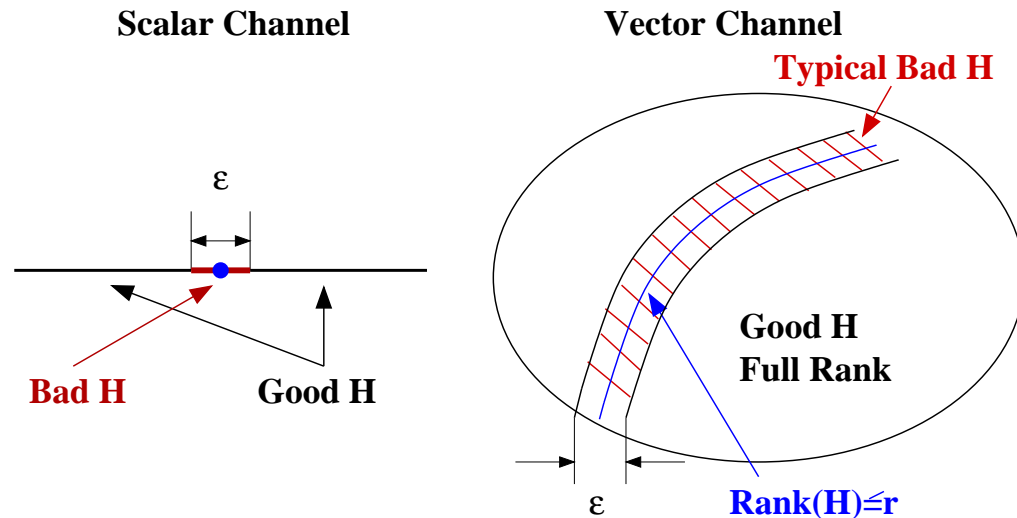

Result: At rate $R = r \log \text{SNR}$, for r integer, outage occurs typically when \mathbf{H} is close to the set $\{\mathbf{H} : \text{rank}(\mathbf{H}) \leq r\}$, with $\epsilon^2 = \text{SNR}^{-1}$.

The dimension of the normal space to the sub-manifold of rank r matrices within the set of all $m \times n$ matrices is $(m - r)(n - r)$.

$$P(\text{Outage}) \approx \text{SNR}^{-(m-r)(n-r)}$$

Achievability: Random Codes

- Outage performance achievable as codeword length $l \rightarrow \infty$.
- For random codes of finite length, errors can occur in three ways:
 - Channel \mathbf{H} is atypically bad (outage)
 - Additive Gaussian noise atypically large.
 - Random codewords are atypically close together.

Achievability: Random Codes

- Outage performance achievable as codeword length $l \rightarrow \infty$.
- For random codes of finite length, errors can occur in three ways:
 - Channel \mathbf{H} is atypically bad (outage)
 - Additive Gaussian noise atypically large.
 - Random codewords are atypically close together.
- We show that as long as $l \geq m + n - 1$, the first event is the dominating one.

Outline

- Precise problem formulation.
- A simple characterization of the optimal tradeoff.
- Sketch of proof.
- Tradeoff as a unified framework to compare different schemes.

Tradeoff Performance of Specific Designs

Provide a **unified framework** to compare different schemes.

Tradeoff Performance of Specific Designs

Provide a **unified framework** to compare different schemes.

For a given scheme, compute

$$r \rightarrow d(r)$$

Compare with $d^*(r)$

Two Diversity-Based Schemes

Focus on two transmit antennas.

$$\mathbf{Y} = \mathbf{H}\mathbf{X} + \mathbf{W}$$

Repetition Scheme:

$$\mathbf{X} = \begin{array}{c} \text{time} \\ \left[\begin{array}{cc} \mathbf{x}_1 & \mathbf{0} \\ \mathbf{0} & \mathbf{x}_1 \end{array} \right] \\ \text{space} \end{array}$$

$$y_1 = \|\mathbf{H}\|x_1 + w_1$$

Two Diversity-Based Schemes

Focus on two transmit antennas.

$$\mathbf{Y} = \mathbf{H}\mathbf{X} + \mathbf{W}$$

Repetition Scheme:

$$\mathbf{X} = \begin{array}{c} \text{time} \\ \left[\begin{array}{cc} \mathbf{x}_1 & \mathbf{0} \\ \mathbf{0} & \mathbf{x}_1 \end{array} \right] \\ \text{space} \end{array}$$

$$y_1 = \|\mathbf{H}\|x_1 + w_1$$

Alamouti Scheme:

$$\mathbf{X} = \begin{array}{c} \text{time} \\ \left[\begin{array}{cc} \mathbf{x}_1 & -\mathbf{x}_2^* \\ \mathbf{x}_2 & \mathbf{x}_1^* \end{array} \right] \\ \text{space} \end{array}$$

$$[y_1 y_2] = \|\mathbf{H}\|[x_1 x_2] + [w_1 w_2]$$

Comparison: 2×1 System

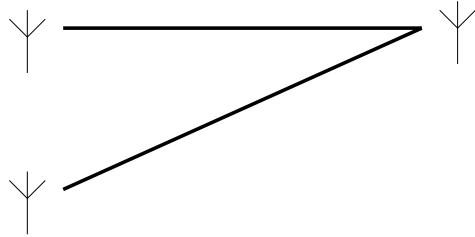

Repetition: $\mathbf{y}_1 = \|\mathbf{H}\| \mathbf{x}_1 + \mathbf{w}$

Alamouti: $[\mathbf{y}_1 \mathbf{y}_2] = \|\mathbf{H}\| [\mathbf{x}_1 \mathbf{x}_2] + [\mathbf{w}_1 \mathbf{w}_2]$

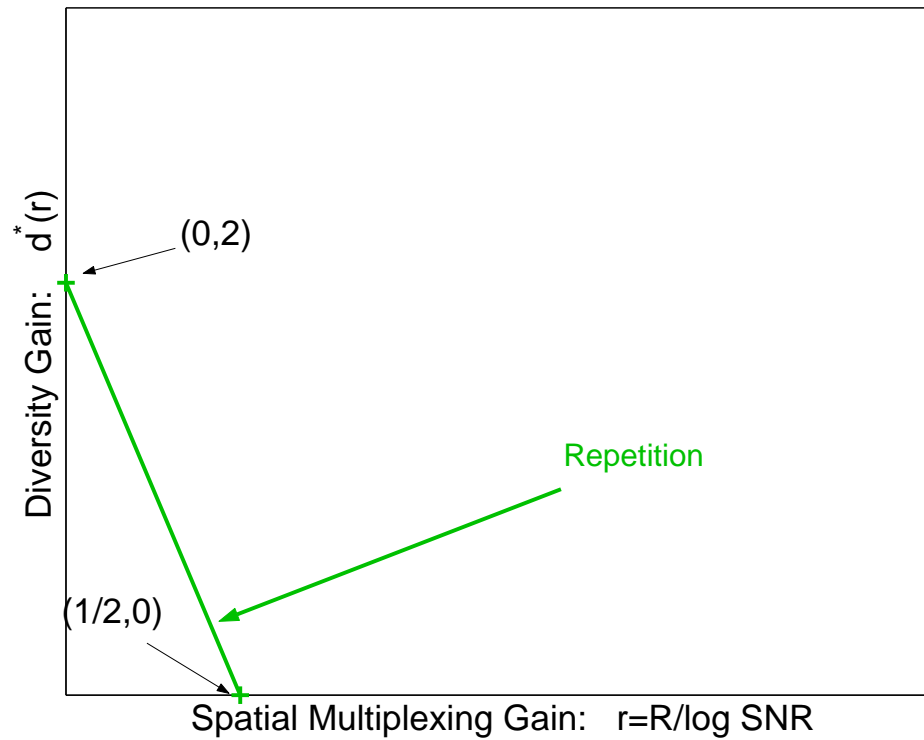

Comparison: 2×1 System

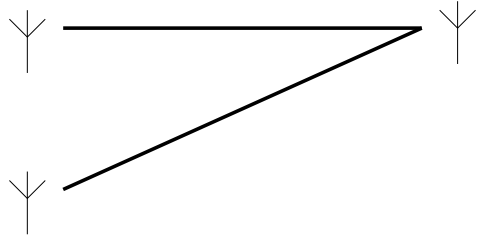

Repetition: $\mathbf{y}_1 = \|\mathbf{H}\| \mathbf{x}_1 + \mathbf{w}$

Alamouti: $[\mathbf{y}_1 \mathbf{y}_2] = \|\mathbf{H}\| [\mathbf{x}_1 \mathbf{x}_2] + [\mathbf{w}_1 \mathbf{w}_2]$

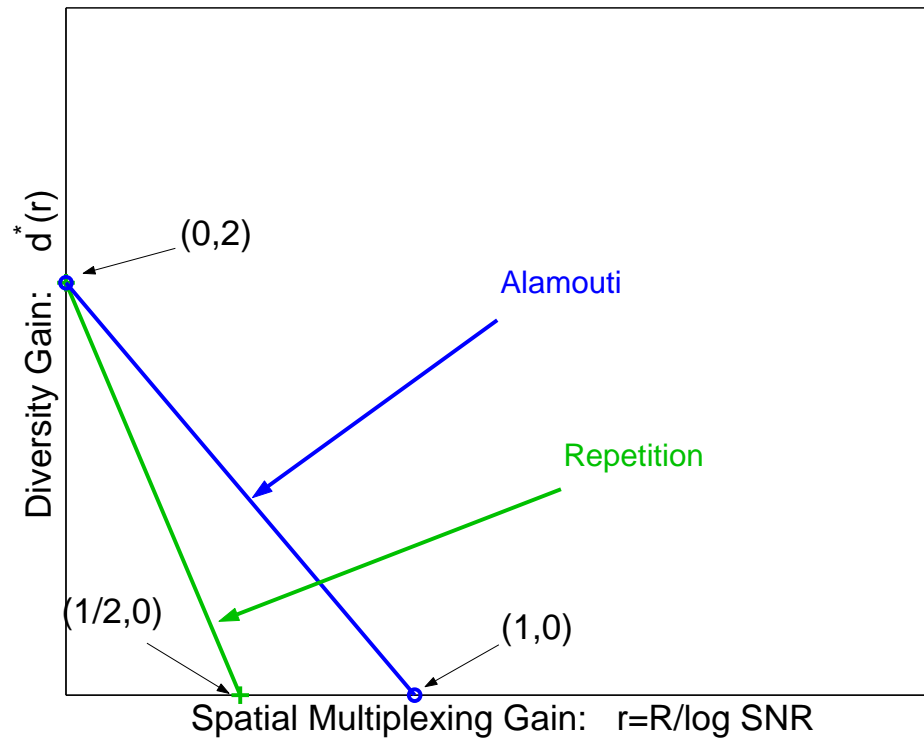

Comparison: 2×1 System

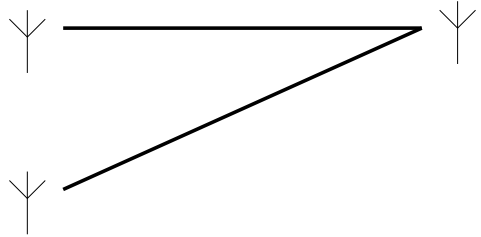

Repetition: $\mathbf{y}_1 = \|\mathbf{H}\| \mathbf{x}_1 + \mathbf{w}$

Alamouti: $[\mathbf{y}_1 \mathbf{y}_2] = \|\mathbf{H}\| [\mathbf{x}_1 \mathbf{x}_2] + [\mathbf{w}_1 \mathbf{w}_2]$

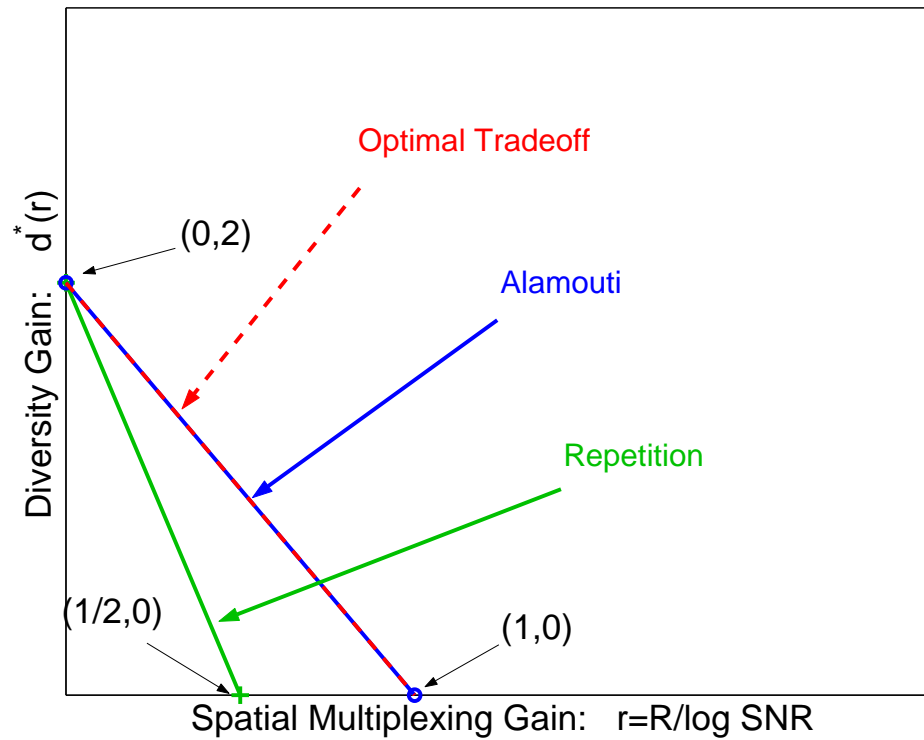

Comparison: 2×2 System

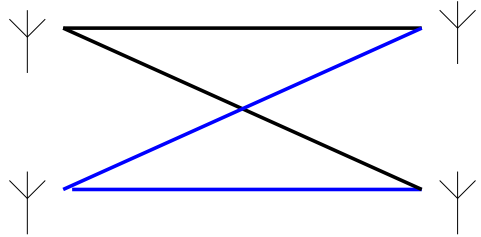

Repetition: $\mathbf{y}_1 = \|\mathbf{H}\| \mathbf{x}_1 + \mathbf{w}$

Alamouti: $[\mathbf{y}_1 \mathbf{y}_2] = \|\mathbf{H}\| [\mathbf{x}_1 \mathbf{x}_2] + [\mathbf{w}_1 \mathbf{w}_2]$

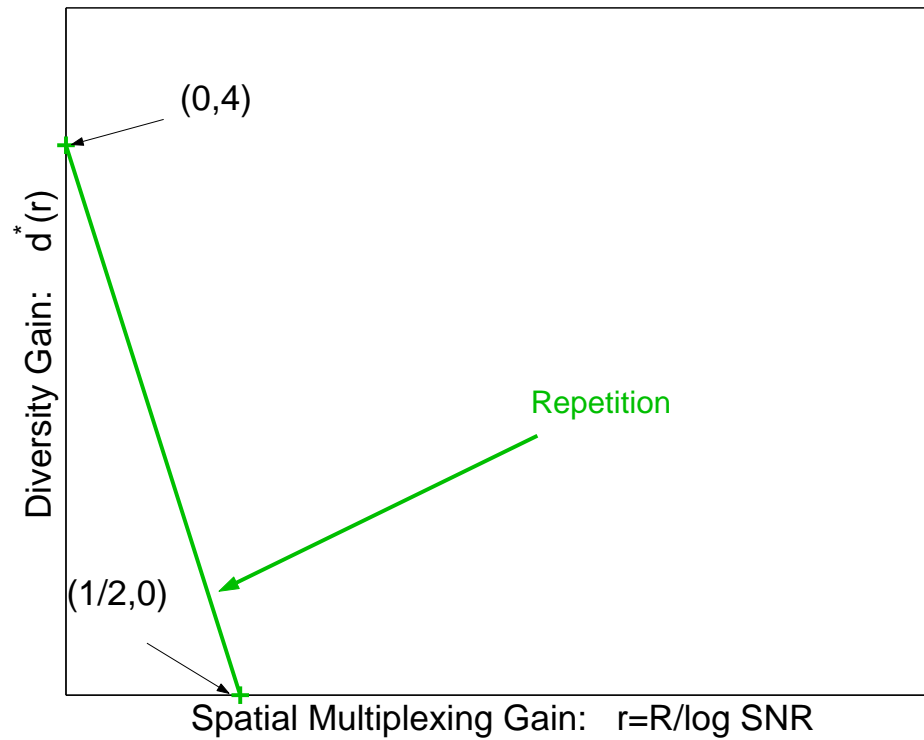

Comparison: 2 x 2 System

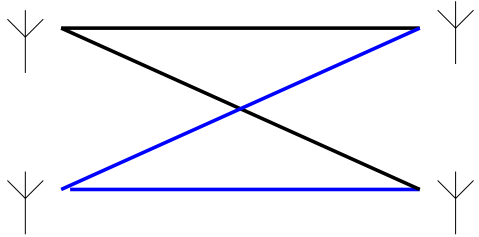

Repetition: $y_1 = \|\mathbf{H}\|x_1 + w$

Alamouti: $[y_1 y_2] = \|\mathbf{H}\|[x_1 x_2] + [w_1 w_2]$

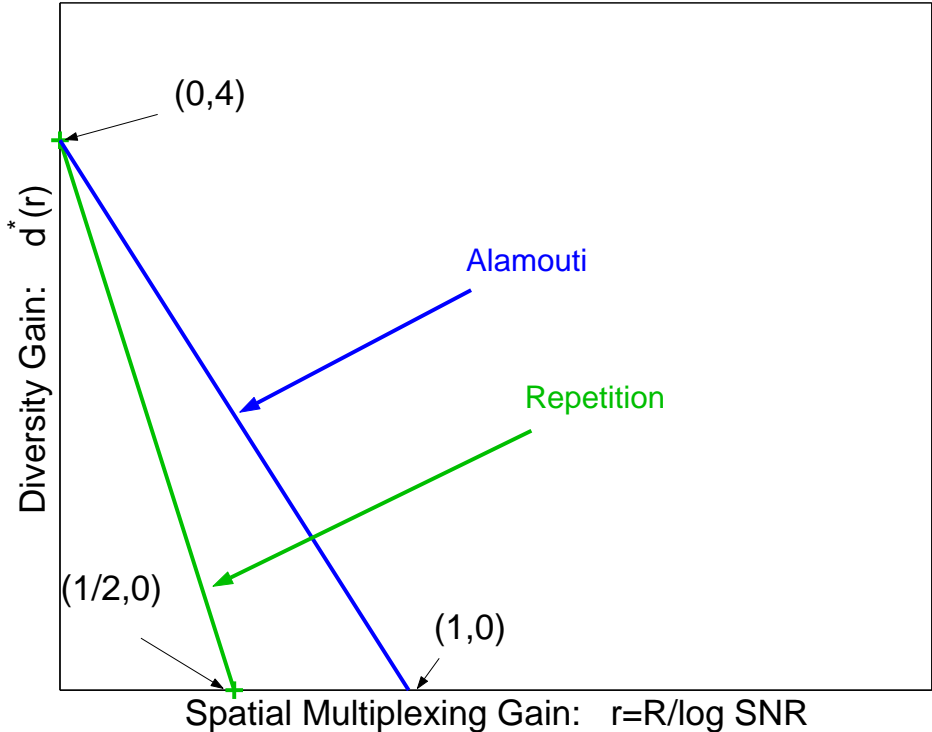

Comparison: 2 × 2 System

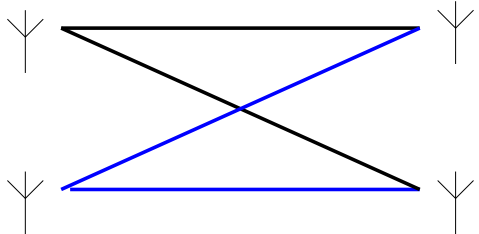

Repetition: $\mathbf{y}_1 = \|\mathbf{H}\| \mathbf{x}_1 + \mathbf{w}$

Alamouti: $[\mathbf{y}_1 \mathbf{y}_2] = \|\mathbf{H}\| [\mathbf{x}_1 \mathbf{x}_2] + [\mathbf{w}_1 \mathbf{w}_2]$

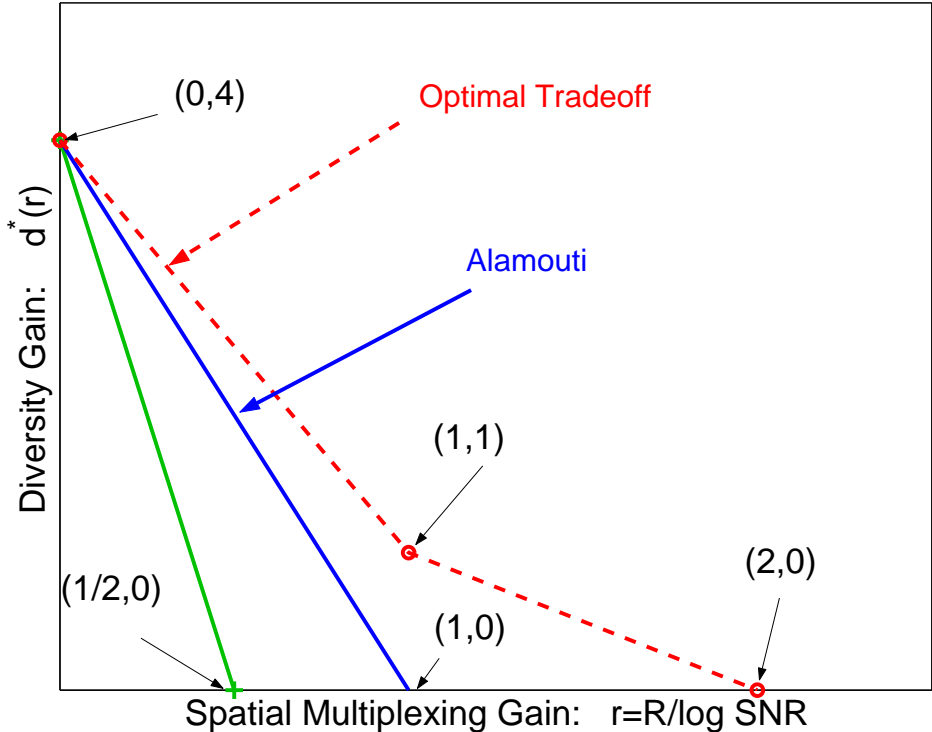

Multiplexing-Based Schemes: BLAST ($n \times n$)

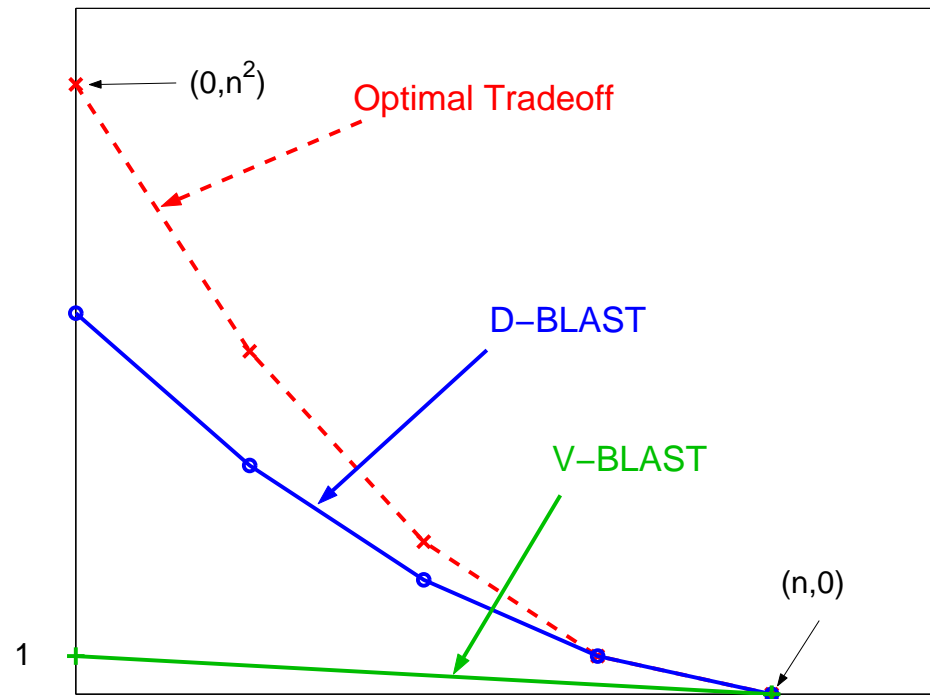

- Make comparison between diversity-based and multiplexing-based schemes
- Pinpoint the problem and improve tradeoff performance.

Multiplexing-Based Schemes: BLAST ($n \times n$)

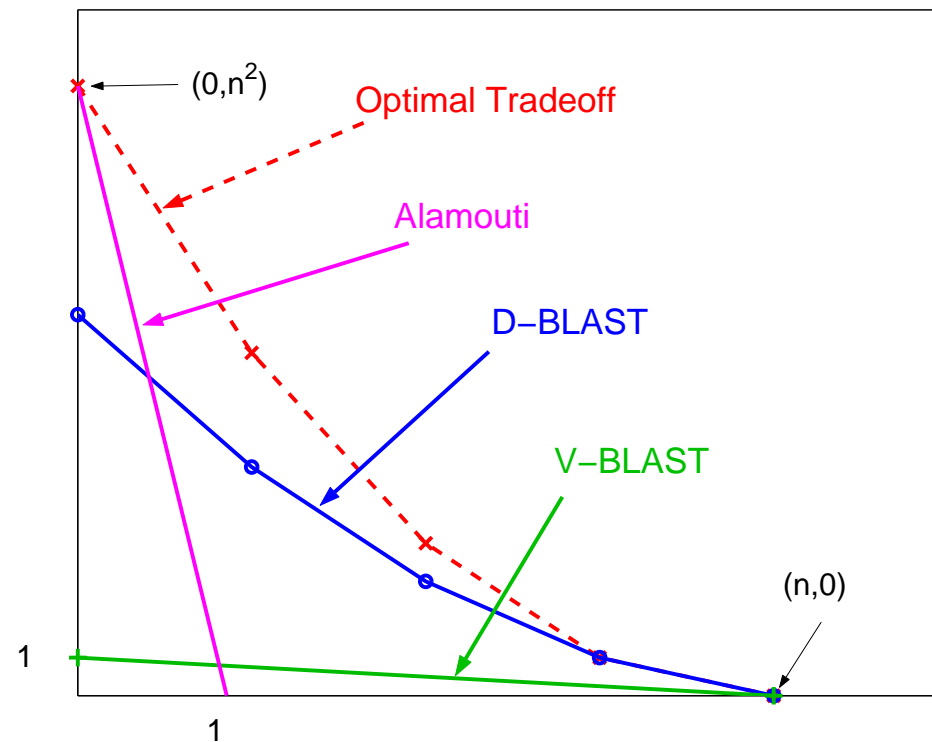

- Make comparison between diversity-based and multiplexing-based schemes
- Pinpoint the problem and improve tradeoff performance.

Multiplexing-Based Schemes: BLAST ($n \times n$)

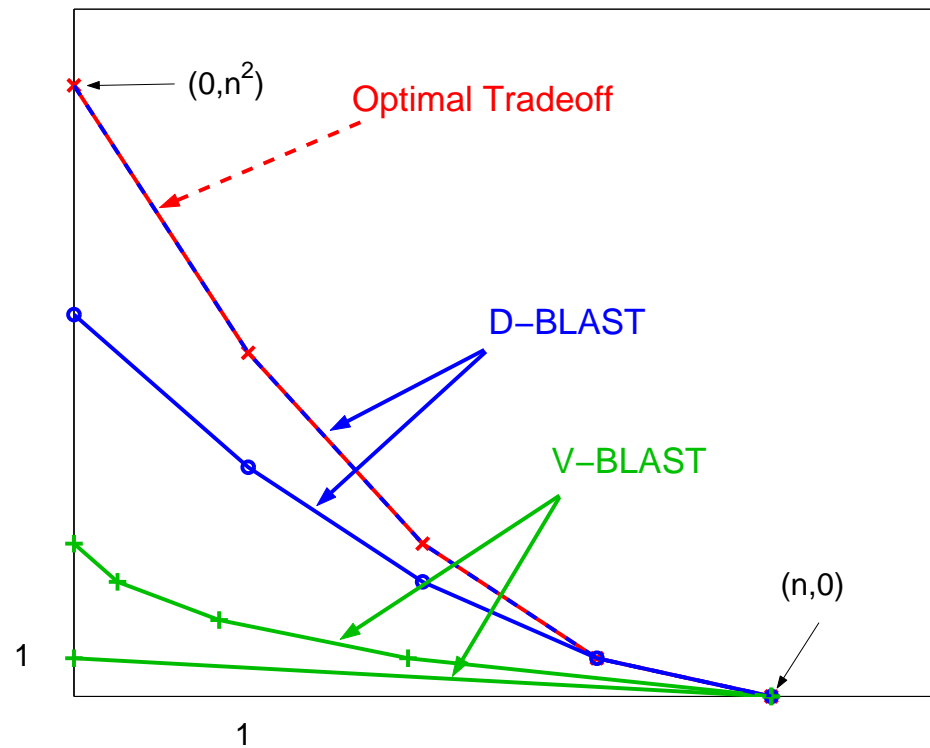

- Make comparison between diversity-based and multiplexing-based schemes
- Pinpoint the problem and improve tradeoff performance.